

PLUMBING PIPING AND EQUIPMENT REPLACEMENT  
PENTHOUSE

APRIL 17, 2017 100%

UNIVERSITY OF TEXAS  
HEALTH SCIENCE CENTER AT HOUSTON  
MEDICAL SCHOOL BUILDING  
6431 FANNIN ST.  
HOUSTON, TEXAS 77030

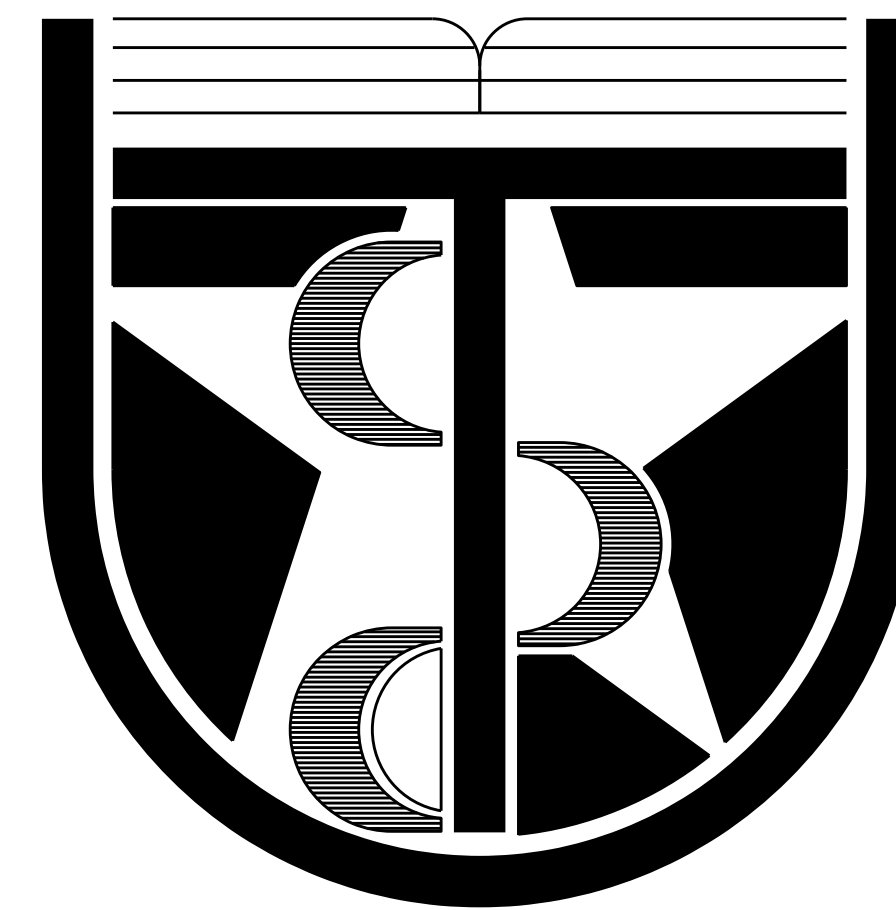

UNIVERSITY OF TEXAS  
HEALTH SCIENCE CENTER AT HOUSTON  
1851 CROSS POINT  
HOUSTON, TEXAS 77054

ENGINEERS

E&C Engineers and Consultants Inc.  
E&C State of Texas registration number is F-003068  
1010 Lamar, Suite 650  
Houston, Texas 77002

Telephone 713-580-8800  
Facsimile 713-580-8888

<http://www.eceng.com>





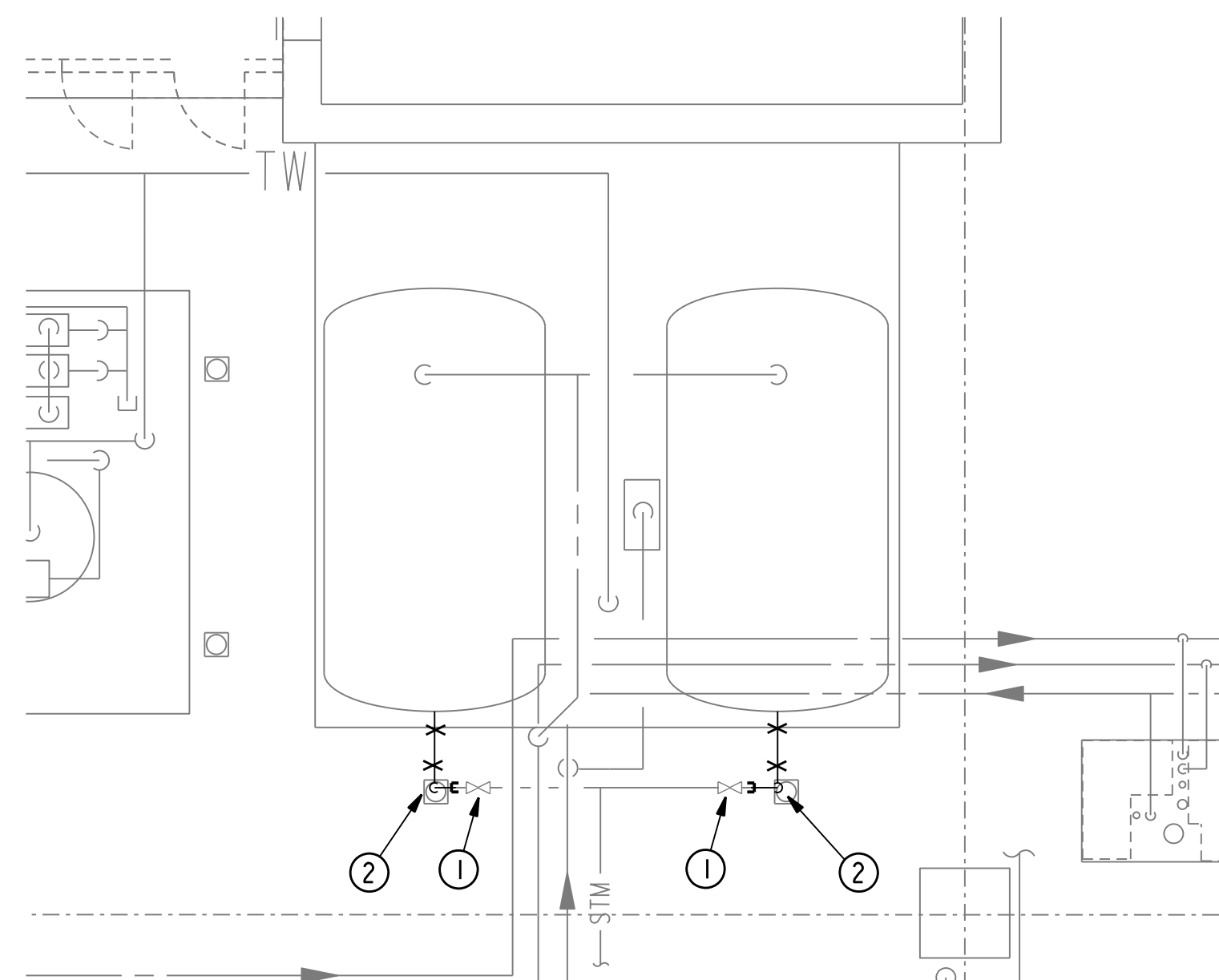

**01 WATER HEATERS SYSTEM - DEMOLITION - SOUTH SIDE**  
SCALE: 1/4" = 1'-0"

**DEMOLITION DRAWING NOTES:**

- ① CAP EXISTING STEAM SUPPLY PIPING ADJACENT TO MAIN SHUT-OFF VALVE SERVING HEATER.
- ② CUT AND CAP EXISTING STEAM CONDENSATE PIPE AT CONNECTION TO PIPING ROUTED DOWN THROUGH THE FLOOR.

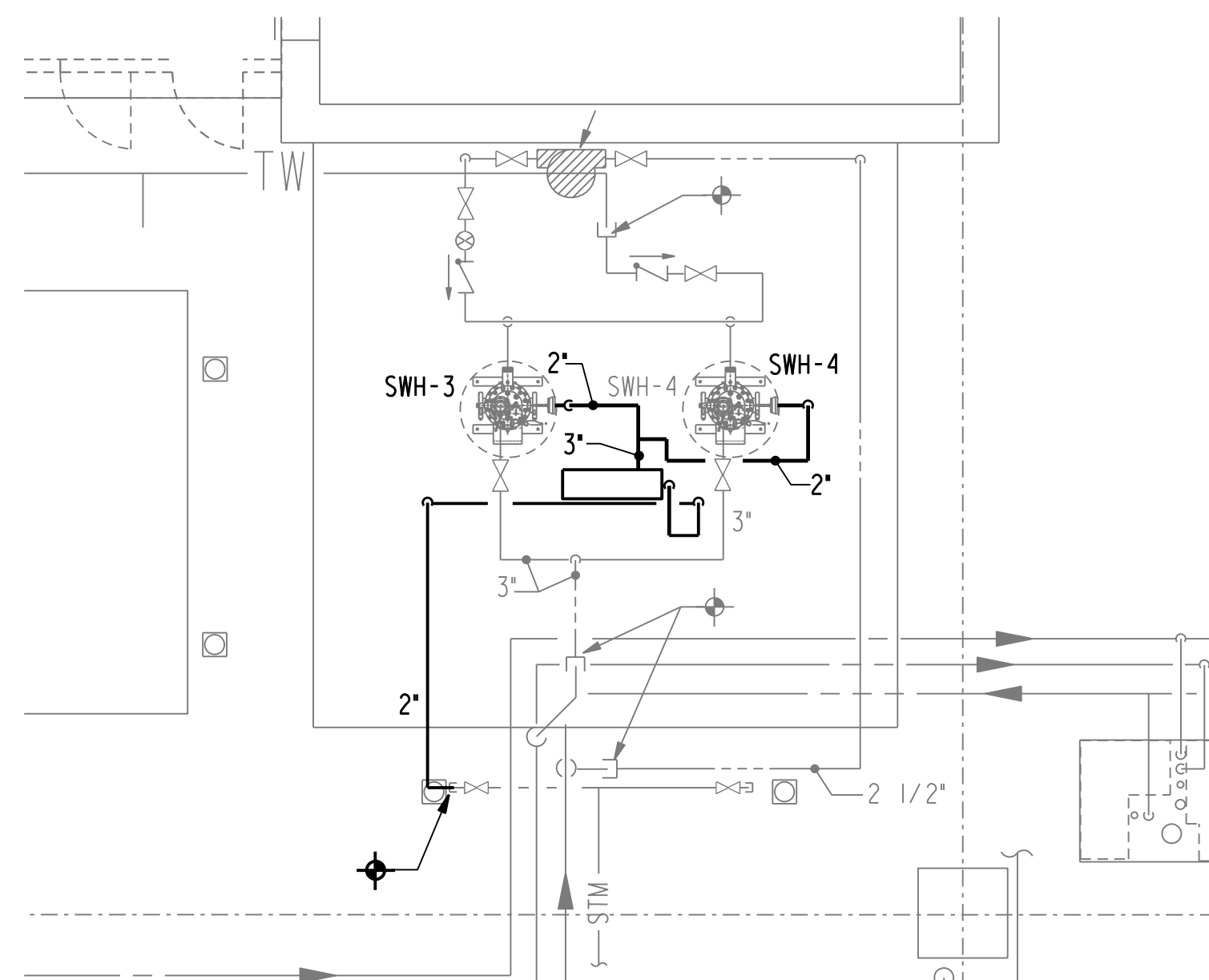

**02 WATER HEATERS SYSTEM - RENOVATION - SOUTH SIDE**  
SCALE: 1/4" = 1'-0"



(EXISTING LAYOUT)

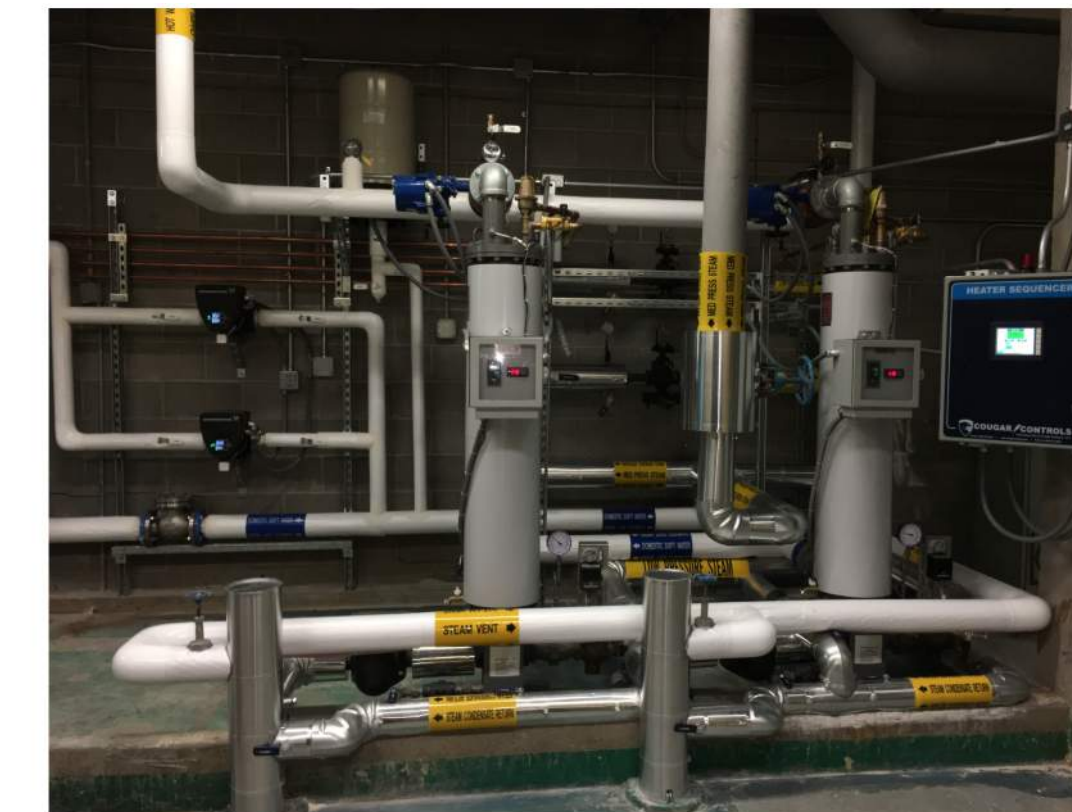

(NEW LAYOUT)  
(SIMILAR TO NORTH SIDE)

**03 WATER HEATERS PHOTOS**  
NOT TO SCALE

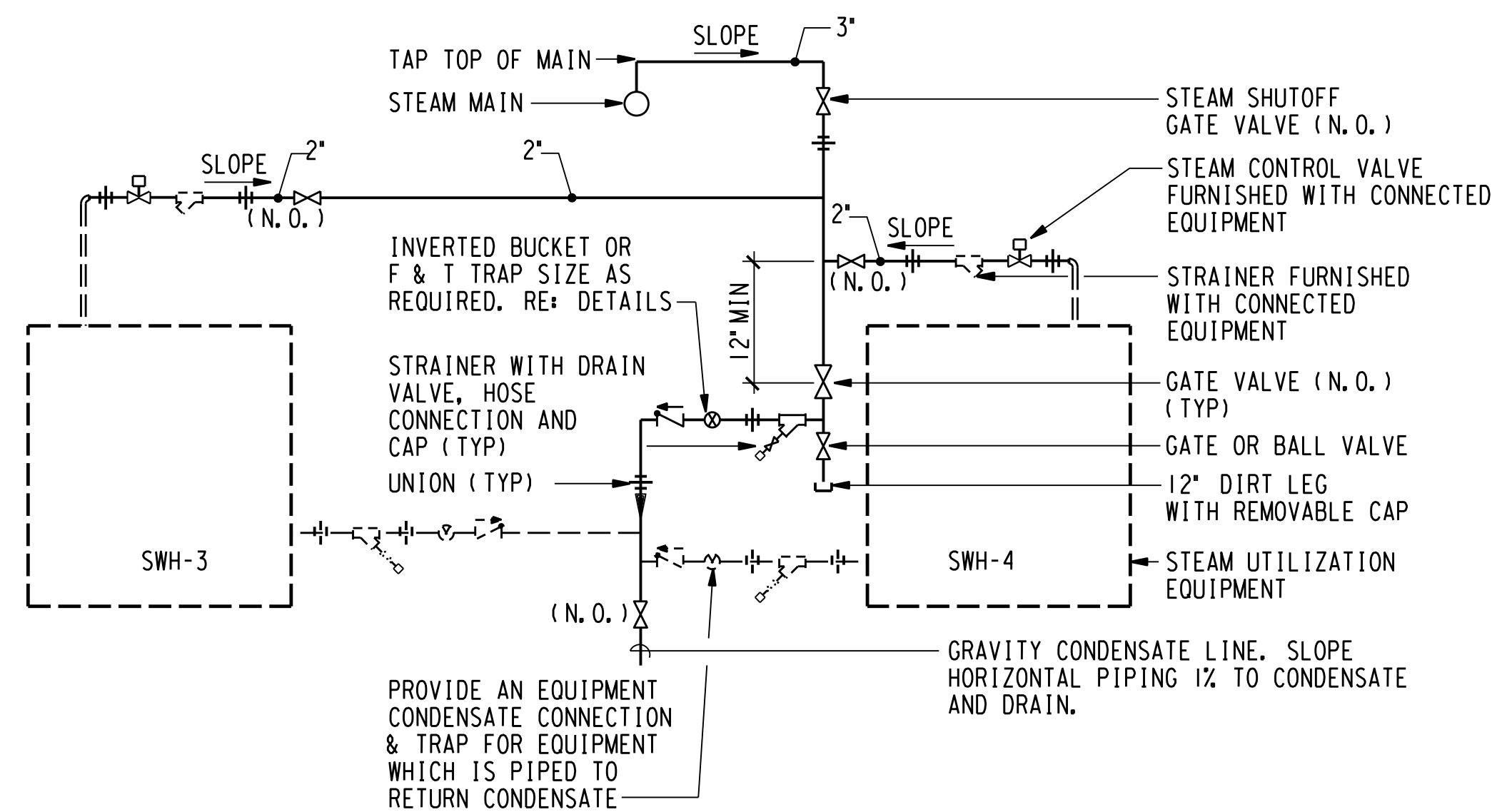

**NOTE:**  
ALL PIPING SHALL BE LOCATED SO AS TO NOT HINDER SERVICE ACCESS TO CONNECTED EQUIPMENT.

**06 STEAM UTILIZATION EQUIPMENT CONNECTION**  
NOT TO SCALE

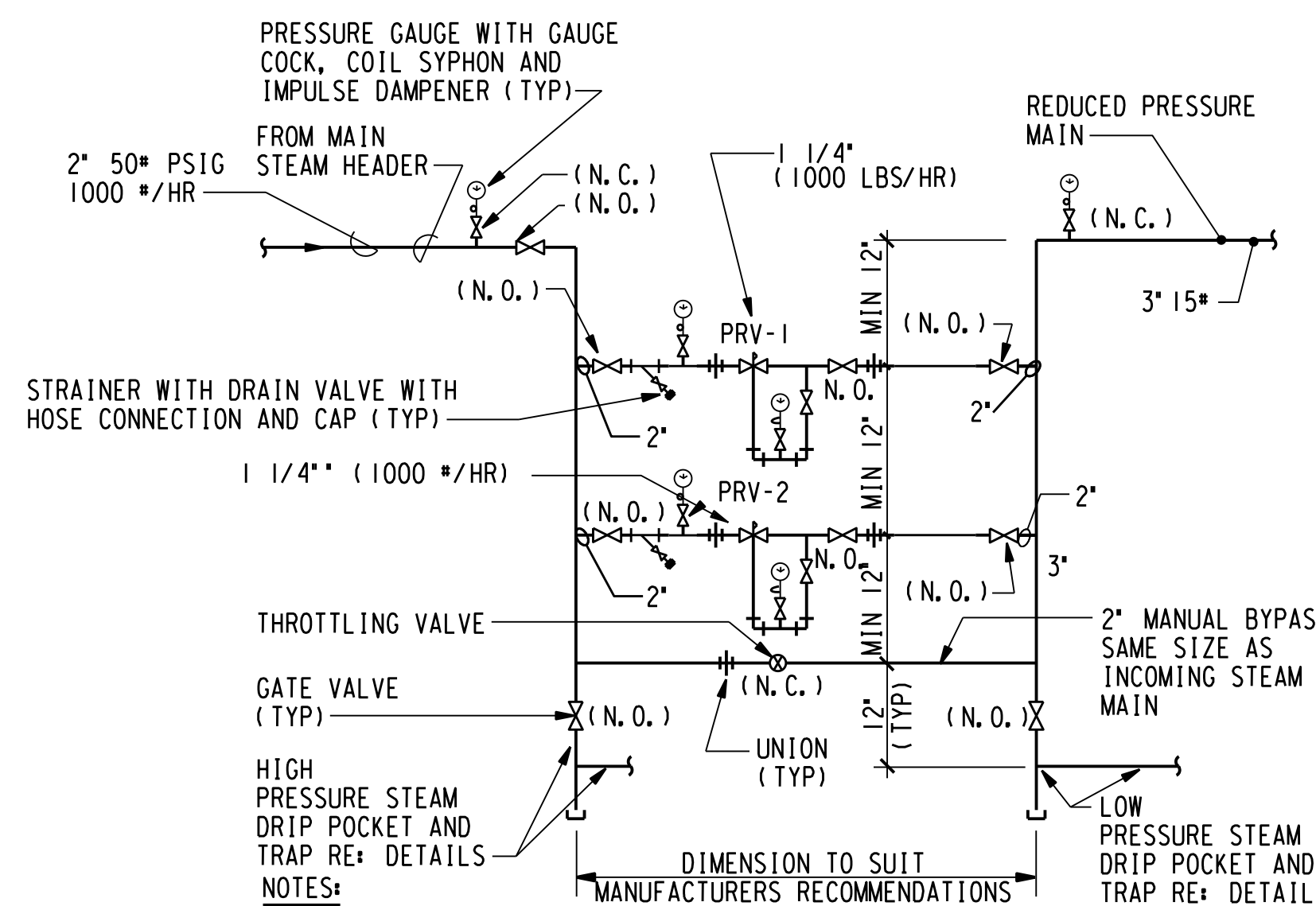

- NOTES:**
1. PRV-1 SIZED FOR 100% OF REDUCED PRESSURE STEAM LOAD AND PRV-2 IS SIZED FOR 100% OF REDUCED PRESSURE STEAM LOAD.
  2. MEDIUM PRESSURE TO LOW PRESSURE.

**05 TYPICAL SINGLE STAGE STEAM PRESSURE REDUCING STATION**  
NOT TO SCALE

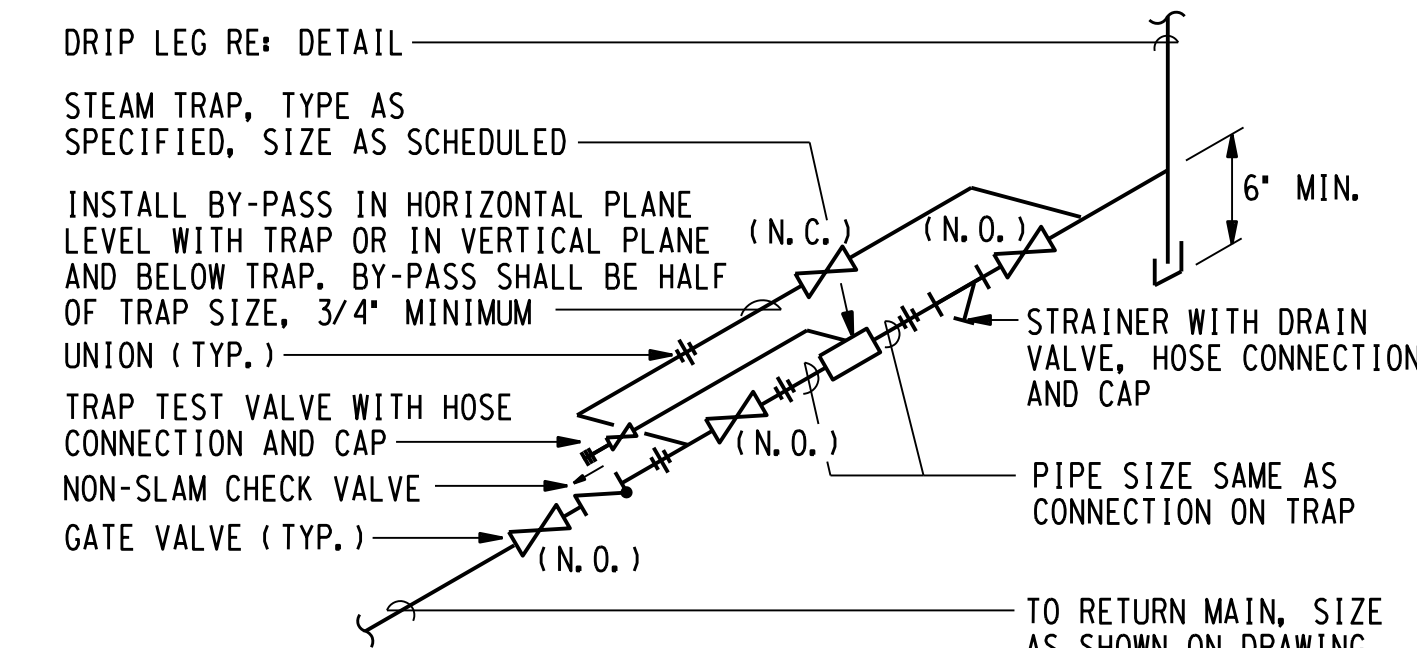

**NOTES:**

1. BY-PASS IS NOT REQUIRED ON THE TRAP PROVIDED FOR THE DRIPPING OF LOW PRESSURE SUPPLY MAINS (15 PSIG OR LESS).
2. WHERE APT'S ARE USED INSTALL ONE LIFT TRAP AND ONE SAFETY LIFT TRAP IN ADDITION TO THE APT.
3. INSTALL MULTIPLE TRAPS (TWO MIN.) ON ALL DEVICES OVER 1000 #/HR OR WHERELIFT TRAPS ARE USED.

**04 TYPICAL STEAM TRAP PIPING**  
NOT TO SCALE

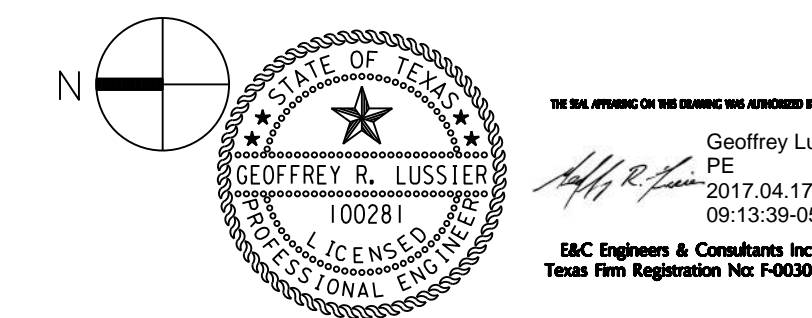
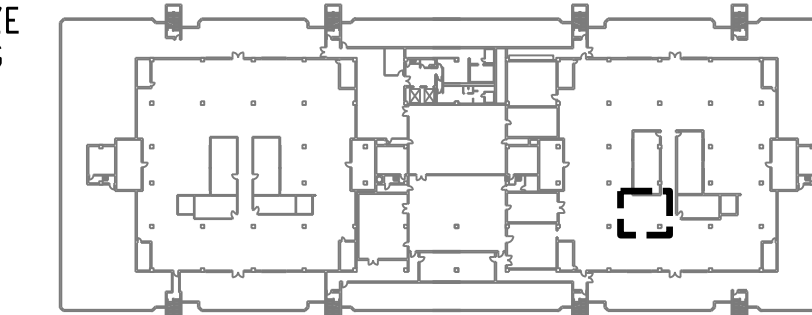

**E&C**  
Engineers & Consultants Inc.  
TX Firm Registration No: F-003068  
1010 Lamar, Suite 650  
Houston, Texas 77002  
Tel 713/580-8800  
Fax 713/580-8888  
www.eceng.com

**UTHSC-H  
MSB PENTHOUSE EQUIPMENT REPLACEMENT**

E&C PROJECT # 3315

**SKETCH: M101**  
**DRAWING: MECHANICAL SOUTH WATER HEATERS**  
**REVISION: 100%**  
**SCALE: 1/4"=1'-0"**  
**DATE: 04-17-2017**



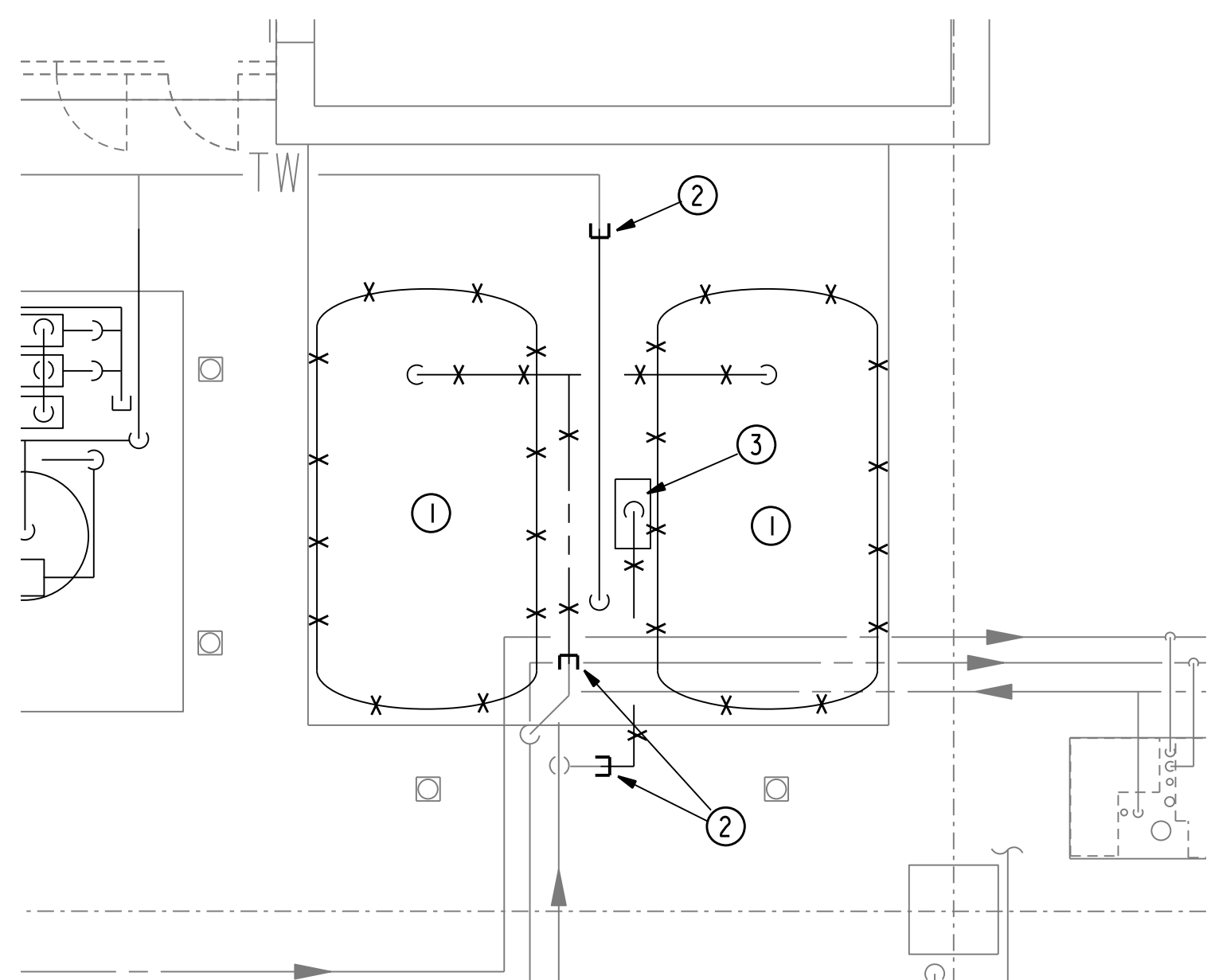

# 01 WATER HEATERS SYSTEM - DEMOLITION - SOUTH SIDE

SCALE: 1/4" = 1'-0"

**DEMOLITION DRAWING NOTES:**

- ① REMOVE EXISTING STEAM DRIVEN DOMESTIC WATER HEATERS, SUPPORT EQUIPMENT AND ASSOCIATED PIPING TO CAP POINTS.
- ② CAP EXISTING PIPING AT THIS APPROXIMATE LOCATION.
- ③ REMOVE EXISTING HOT WATER RECIRCULATION PUMP.

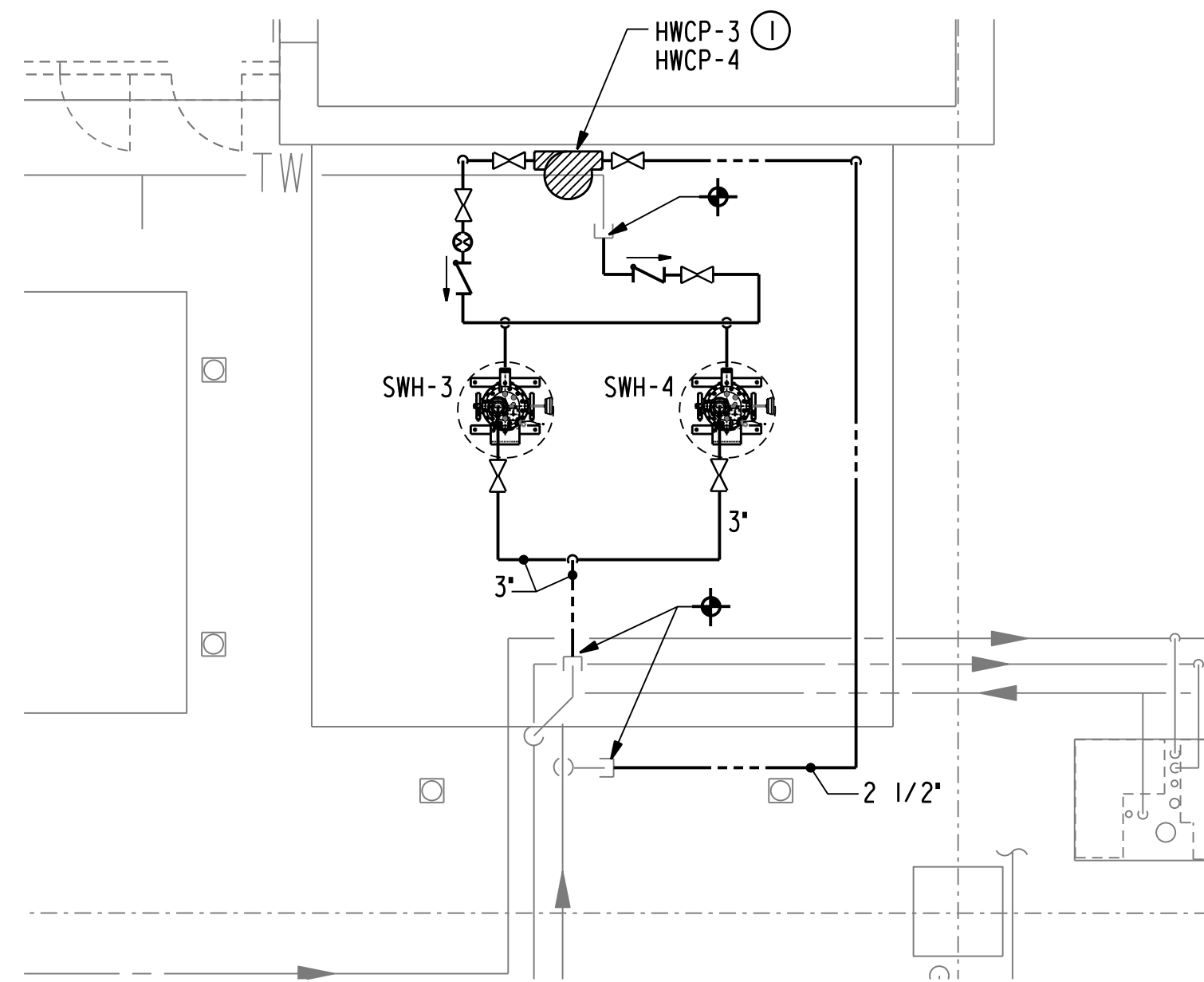

# 02 WATER HEATERS SYSTEM - RENOVATION - SOUTH SIDE

SCALE: 1/4" = 1'-0"

**RENOVATION DRAWING NOTES:**

- ① TWO HOT WATER HEATER CIRCULATION PUMPS STACKED ON WALL.



(EXISTING LAYOUT)



(NEW LAYOUT) (SIMILAR TO NORTH SIDE)

# 03 WATER HEATER PHOTOS

NOT TO SCALE

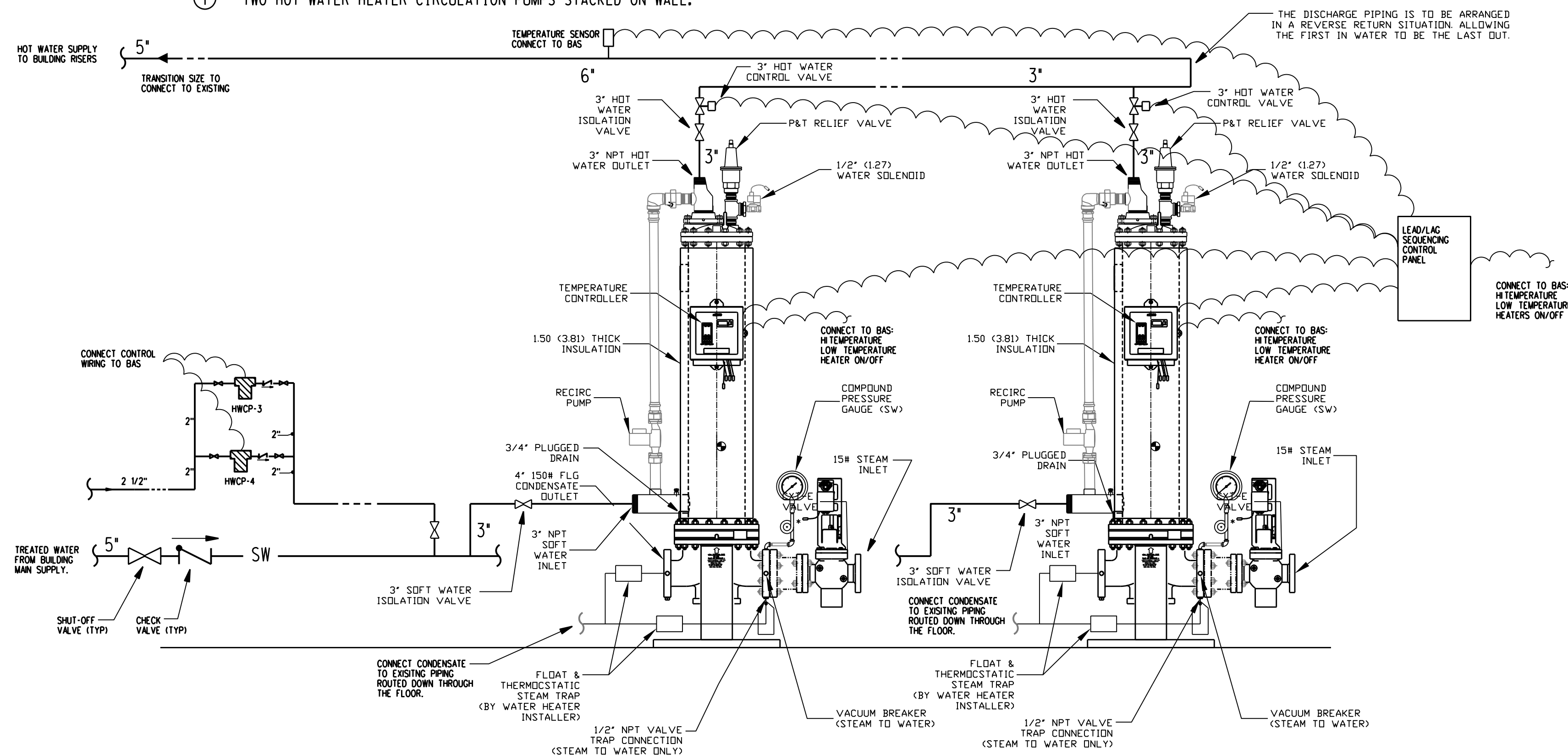

# 04 STEAM WATER HEATERS

NOT TO SCALE

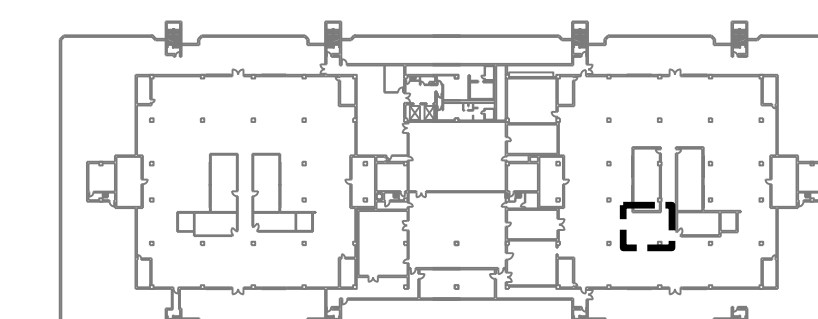

STATE OF TEXAS  
 GEOFFREY R. LUSSIER  
 100281  
 LICENSED PROFESSIONAL ENGINEER  
 2017.04.17  
 09:13:39-0500  
 E&C Engineers & Consultants Inc.  
 Texas Firm Registration No: F-003068

**E&C**  
 Engineers & Consultants Inc.  
 TX Firm Registration No: F-003068  
 1010 Lamar, Suite 650  
 Houston, Texas 77002  
 Tel 713/580-8800  
 Fax 713/580-8888  
 www.eceng.com

## UTHSC-H MSB PENTHOUSE EQUIPMENT REPLACEMENT

E&C PROJECT # 3315

SKETCH: P101  
 DRAWING: PLUMBING SOUTH WATER HEATERS  
 REVISION: 100%  
 SCALE: 1/4"=1'-0"  
 DATE: 04-17-2017



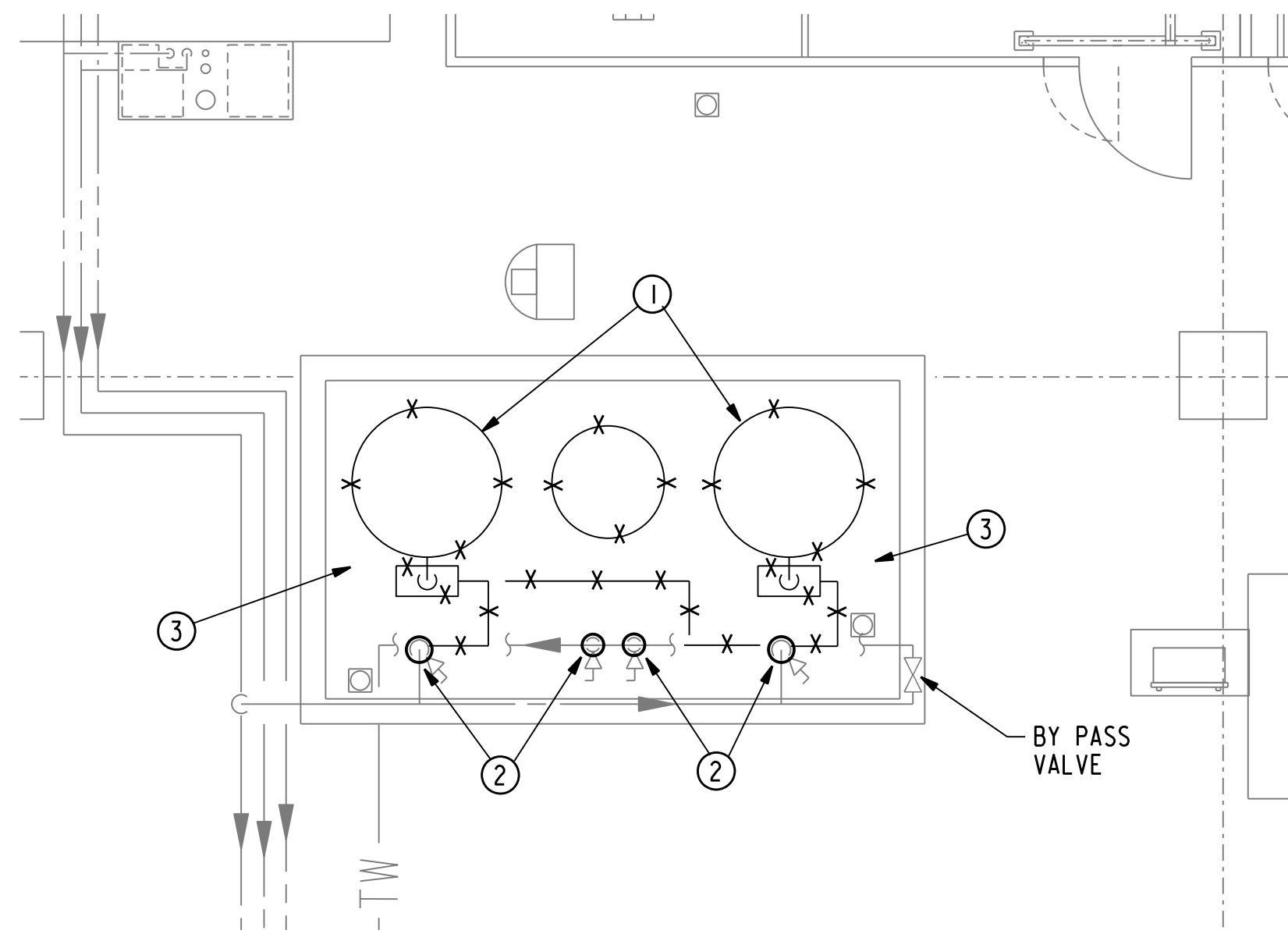

### 01 WATER SOFTNER SYSTEM DEMOLITION PLAN - SOUTH SIDE

SCALE: 1/4" = 1' - 0"

**DEMOLITION DRAWING NOTES:**

- ① REMOVE EXISTING WATER SOFTENING SYSTEM, ASSOCIATED PIPING, VALVES AND SUPPORTING EQUIPMENT. CAP PIPING UP AND DOWN STREAM OF MAIN VALVES, KEEPING THE WATER FLOWING IN BYPASS DURING THE RENOVATION.
- ② THESE VALVES WILL BE CAPPED IN THE VERTICAL SECTION OF PIPE.
- ③ CLEAN AND PREPARE EXISTING HOUSEKEEPING PAD FOR NEW SYSTEM TO BE INSTALLED.

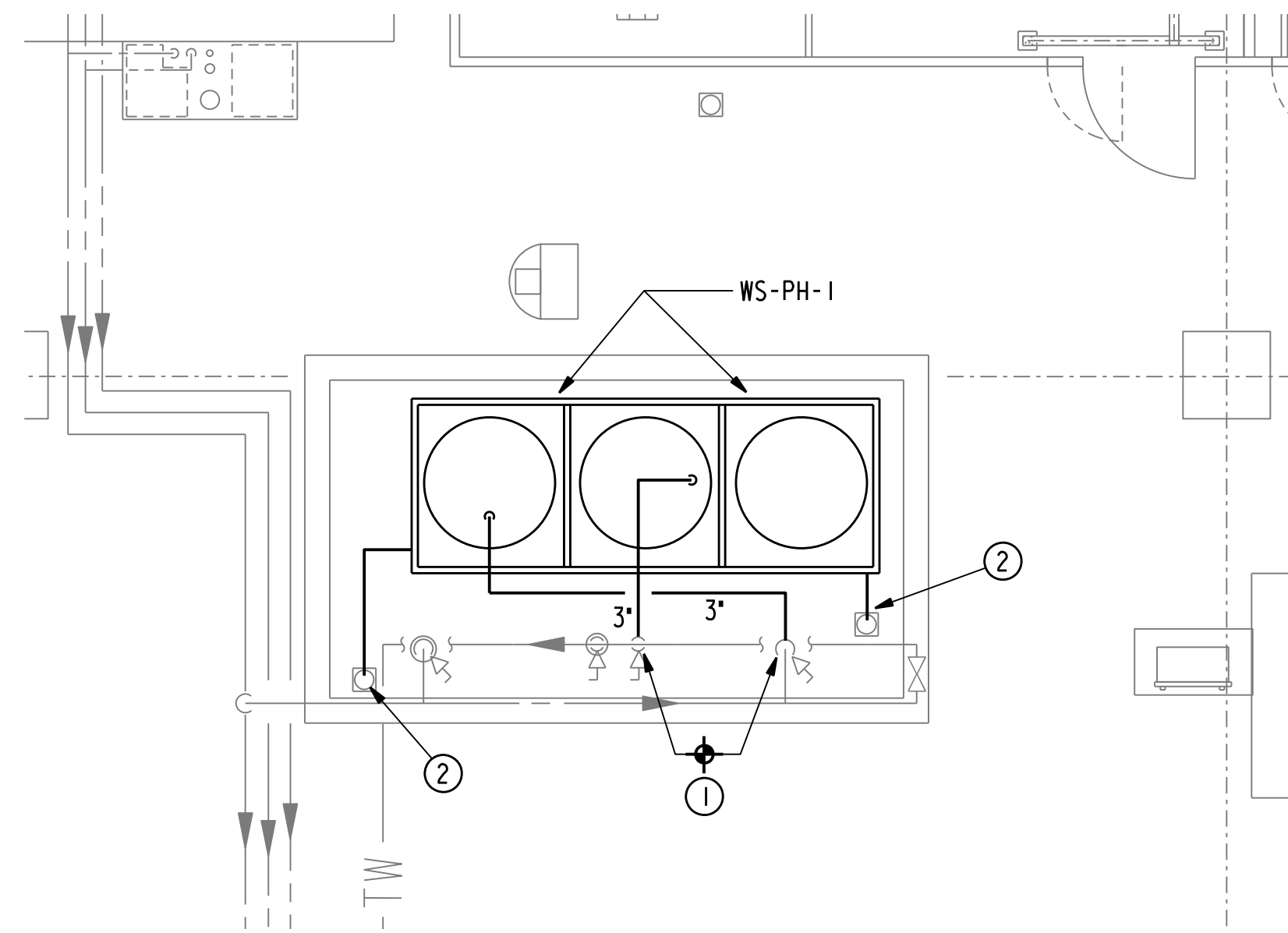

### 02 WATER SOFTNER SYSTEM RENOVATION PLAN - SOUTH SIDE

SCALE: 1/4" = 1' - 0"

**RENOVATION DRAWING NOTES:**

- ① CONNECT NEW PIPING TO EXISTING VALVES.
- ② ROUTE NEW DRAIN LINES TO EXISTING FLOOR DRAIN LOCATIONS.

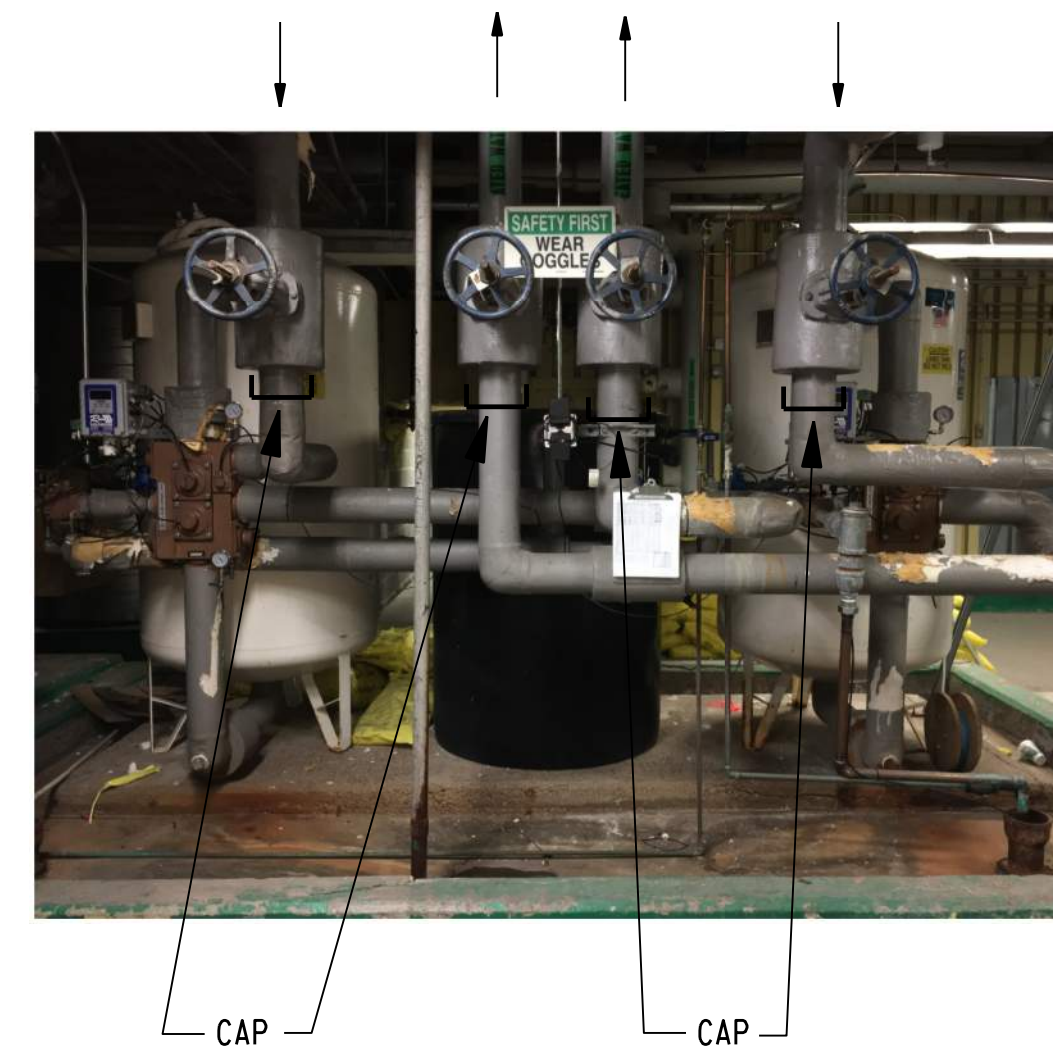

### 03 EXISTING INSTALLATION PHOTOS NOT TO SCALE

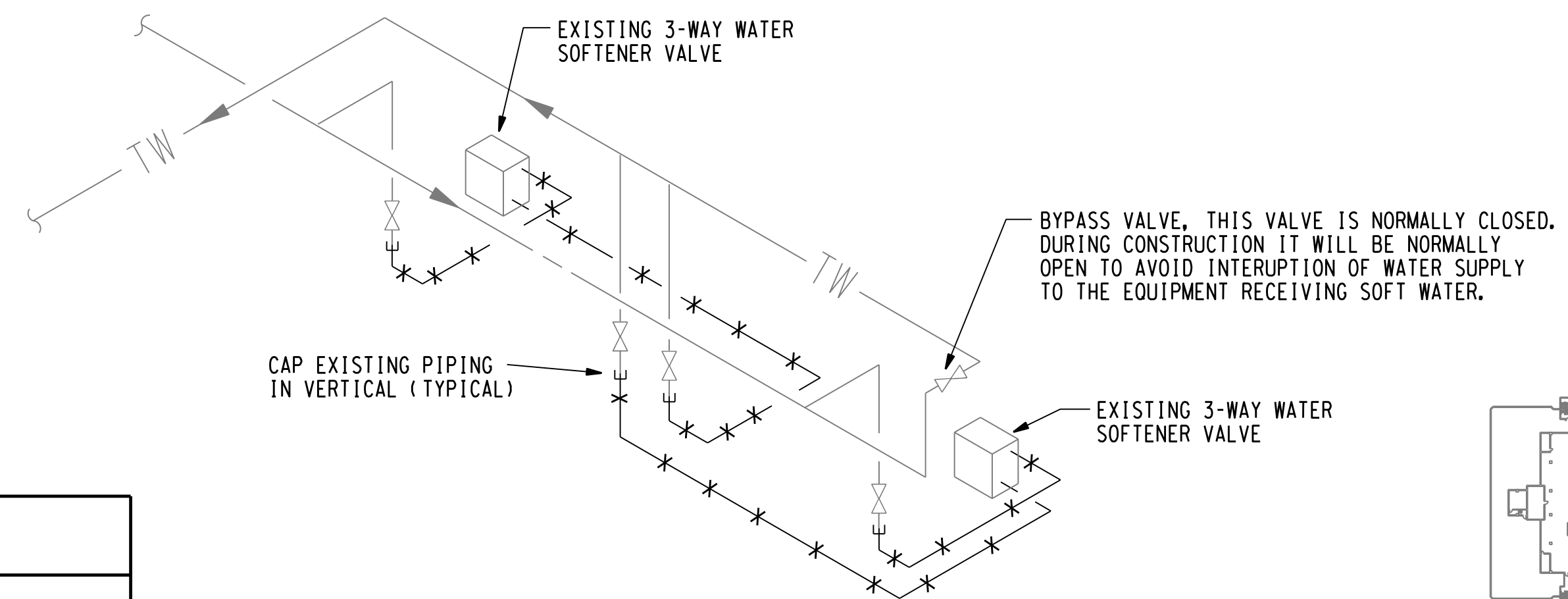

WATER SOFTENER SCHEDULE											
MARK	LOCATION	TYPE	GRAIN PER DAY REMOVAL	RESIN CAPACITY (CUBIC FEET)	CONT. FLOW (GPM @ 15PSI)	BACKWASH (GPM)	BRINE CAPACITY (LBS)	MEASUREMENTS TWIN (TOTAL SPACE REQUIRED)	MINERAL TANK SIZE	BRINE TANK	REMARKS
WS-PH-1	PENTHOUSE NORTH	WATER SOFTENER	900,000	30	165	45	1840	150x56x94	42x60	42x60	WATERTECK SERVICES WTS-900-3

### 04 WATER SOFTENER ONE LINE NOT TO SCALE

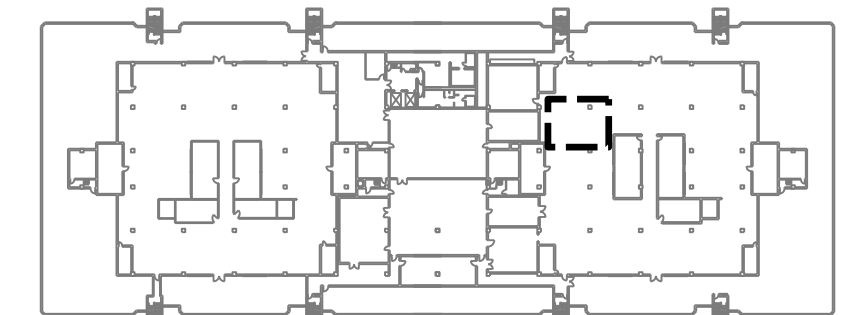

STATE OF TEXAS  
 GEOFFREY R. LUSSIER  
 LICENSED PROFESSIONAL ENGINEER  
 100281  
 2017.04.17  
 09:13:39-0500  
 E&C Engineers & Consultants Inc.  
 Texas Firm Registration No: F-003068

**E&C**  
 Engineers & Consultants Inc.  
 TX Firm Registration No: F-003068  
 1010 Lamar, Suite 650  
 Houston, Texas 77002  
 Tel 713/580-8800  
 Fax 713/580-8888  
 www.eceng.com

## UTHSC-H MSB PENTHOUSE EQUIPMENT REPLACEMENT

E&C PROJECT # 3315

SKETCH: P102  
 DRAWING: PLUMBING SOUTH WATER SOFTNERS  
 REVISION: 100%  
 SCALE: 1/4"=1'-0"  
 DATE: 04-17-2017



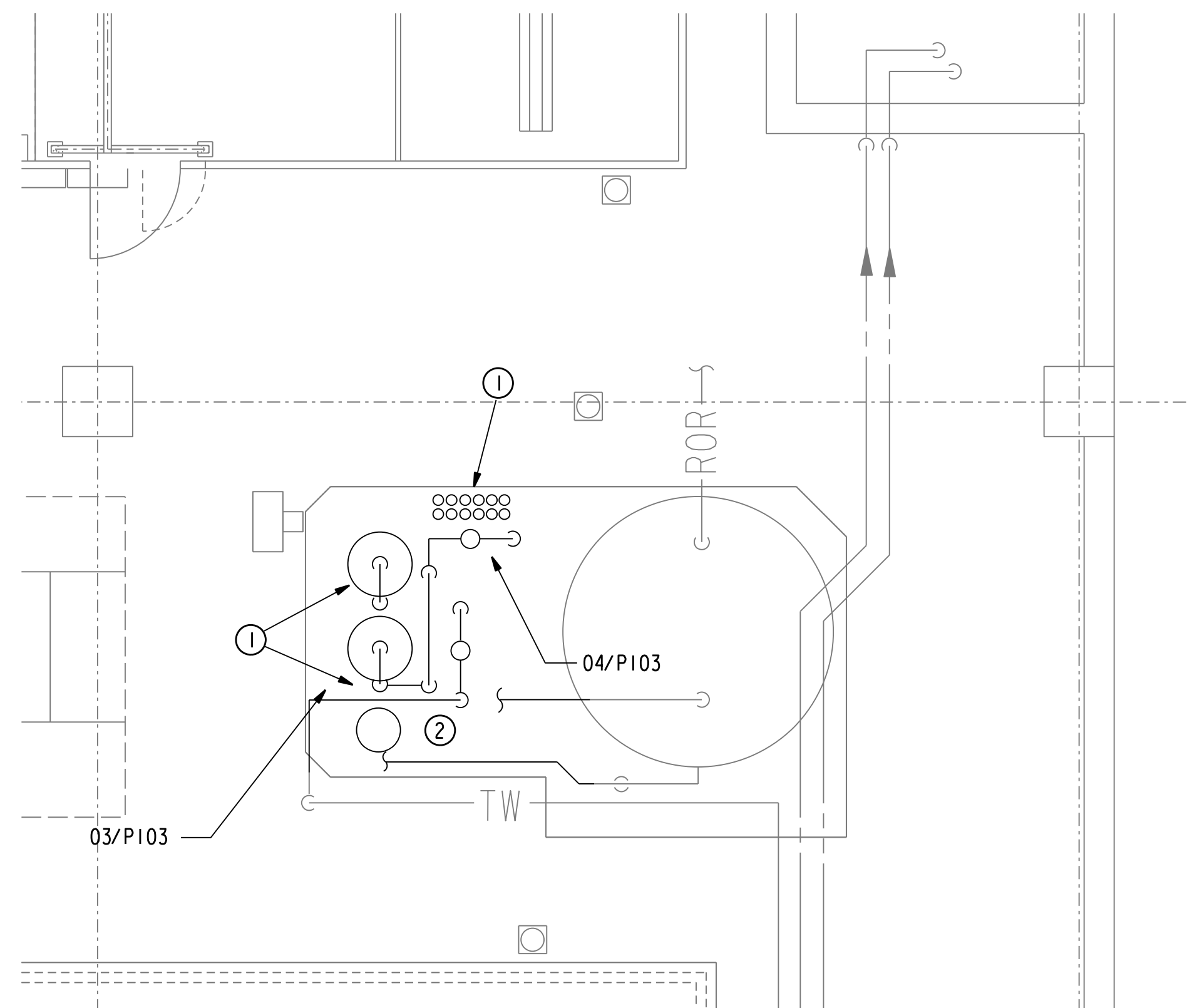

# 01 REVERSE OSMOSIS SYSTEM - DEMOLITION - NORTH SIDE

SCALE: 1/4" = 1'-0"

### DEMOLITION DRAWING NOTES:

- ① THE EXISTING RO SYSTEM IS TO REMAIN. ALL EXISTING PIPING IS TO REMAIN. SPECIFIC SECTIONS/PARTS ARE TO BE REPLACED OR REFURBISHED. RE: 02/P104 FOR MORE INFORMATION. ALL OF THE EQUIPMENT IS TO BE REPLACED AT THE SAME LOCATION.
- ② EXISTING PUMPS ARE TO BE REMOVED AND REPLACED. MODIFY THE EXISTING PIPING REQUIRED TO FACILITATE THE NEW PUMP INSTALLATION.

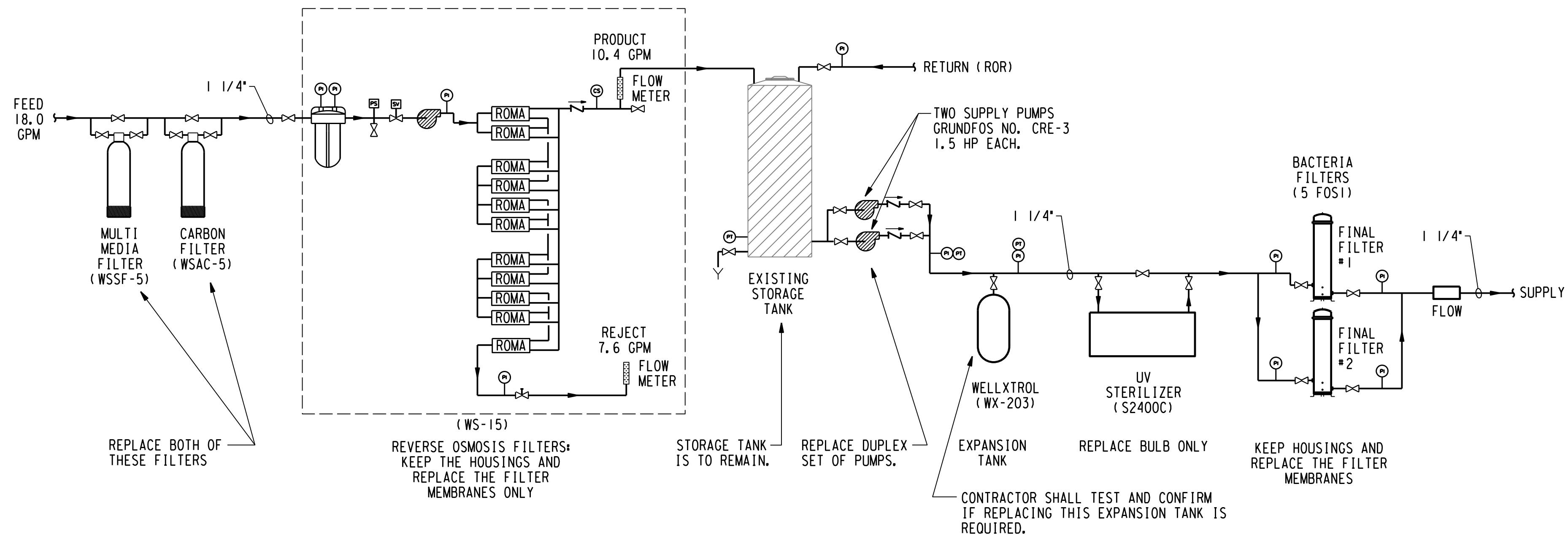

# 02 REVERSE OSMOSIS DIAGRAM

NOT TO SCALE

\*\* ALL MODEL NUMBERS LISTED IN BRACKETS '( ) ' ARE WATERTECK SERVICES NUMBERS.



# 03 RO SYSTEM LOOKING SOUTH

NOT TO SCALE



# 04 RO SYSTEM LOOKING EAST

NOT TO SCALE

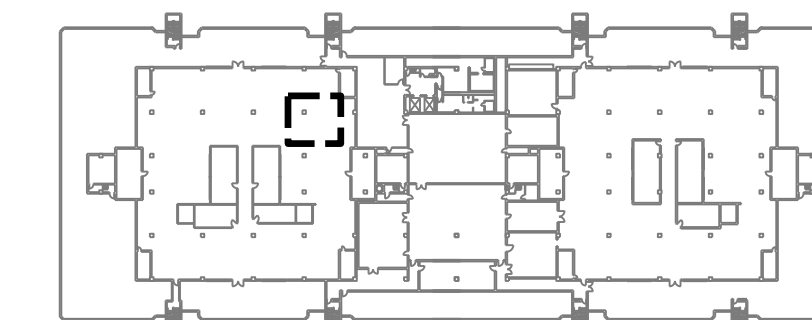

STATE OF TEXAS  
 GEOFFREY R. LUSSIER  
 100281  
 LICENSED PROFESSIONAL ENGINEER  
 2017.04.17  
 09:13:38-05'00"  
 E&C Engineers & Consultants Inc.  
 Texas Firm Registration No: F-003068

**E&C**  
 Engineers & Consultants Inc.  
 TX Firm Registration No: F-003068  
 1010 Lamar, Suite 650  
 Houston, Texas 77002  
 Tel 713/580-8800  
 Fax 713/580-8888  
 www.eceng.com

# UTHSC-H MSB PENTHOUSE EQUIPMENT REPLACEMENT

E&C PROJECT # 3315

SKETCH: P103  
 DRAWING: PLUMBING NORTH REVERSE OSMOSIS  
 REVISION: 100%  
 SCALE: 1/4"=1'-0"  
 DATE: 04-17-2017



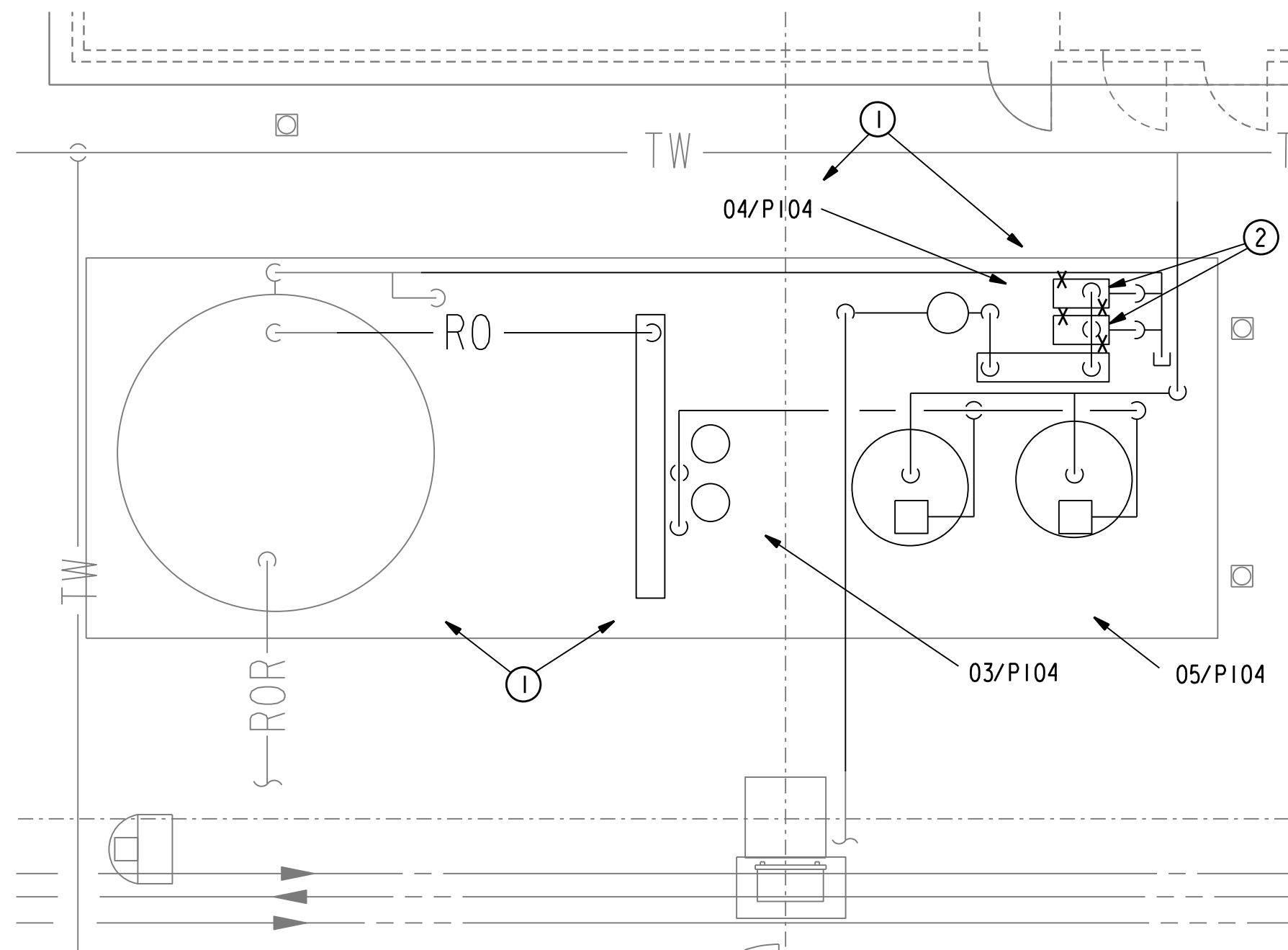

**01** REVERSE OSMOSIS SYSTEM -  
DEMOLITION - SOUTH SIDE  
SCALE: 1/4" = 1' - 0"

DEMOLITION DRAWING NOTES:

- ① THE EXISTING RO SYSTEM IS TO REMAIN. ALL EXISTING PIPING IS TO REMAIN. SPECIFIC SECTIONS/PARTS ARE TO BE REPLACED OR REFURBISHED. RE: 02/P104 FOR MORE INFORMATION. ALL OF THE EQUIPMENT IS TO BE REPLACED AT THE SAME LOCATION.
- ② EXISTING PUMPS ARE TO BE REMOVED AND REPLACED. MODIFY THE EXISTING PIPING REQUIRED TO FACILITATE THE NEW PUMP INSTALLATION.

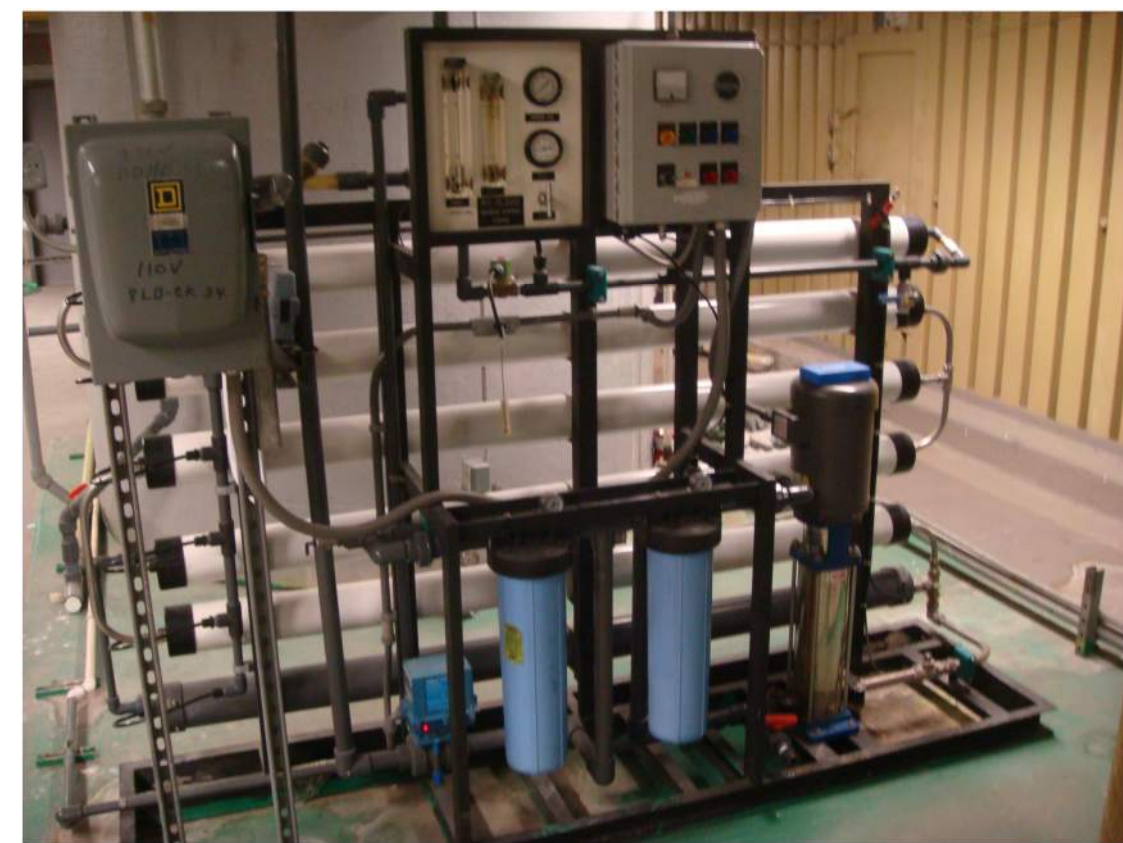

**03** RO SYSTEM LOOKING NORTH  
NOT TO SCALE



**04** RO SYSTEM LOOKING SOUTH  
NOT TO SCALE



**05** CARBON FILTERS LOOKING EAST  
NOT TO SCALE

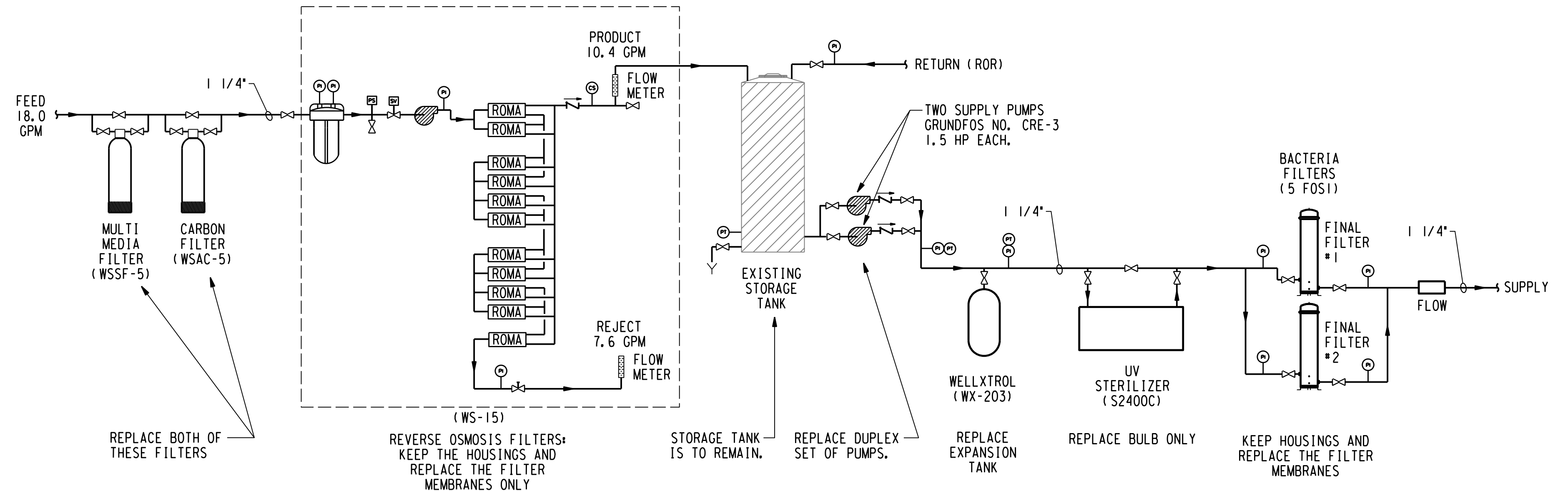

**02** REVERSE OSMOSIS DIAGRAM  
NOT TO SCALE

\*\* ALL MODEL NUMBERS LISTED IN BRACKETS "( )" ARE WATERTECK SERVICES NUMBERS.

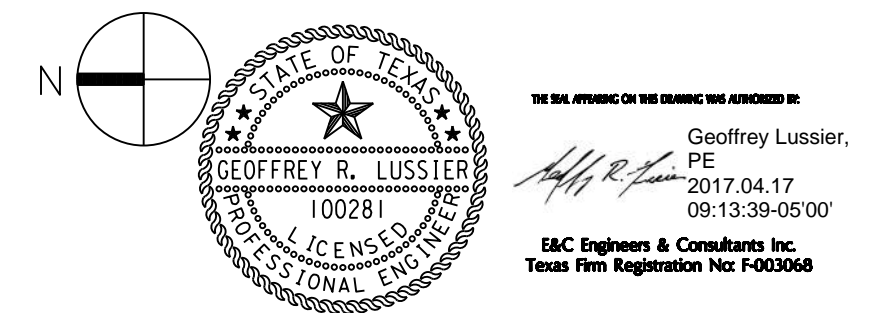
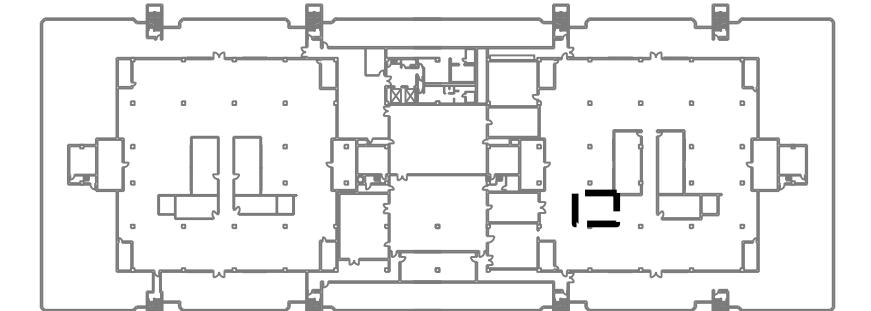

**E&C**  
Engineers & Consultants Inc.  
TX Firm Registration No: F-003068  
1010 Lamar, Suite 650  
Houston, Texas 77002  
Tel 713/580-8800  
Fax 713/580-8888  
www.eceng.com

UTHSC-H  
MSB PENTHOUSE EQUIPMENT REPLACEMENT

E&C PROJECT # 3315

SKETCH: P104  
DRAWING: PLUMBING SOUTH REVERSE OSMOSIS  
REVISION: 100%  
SCALE: 1/4"=1'-0"  
DATE: 04-17-2017



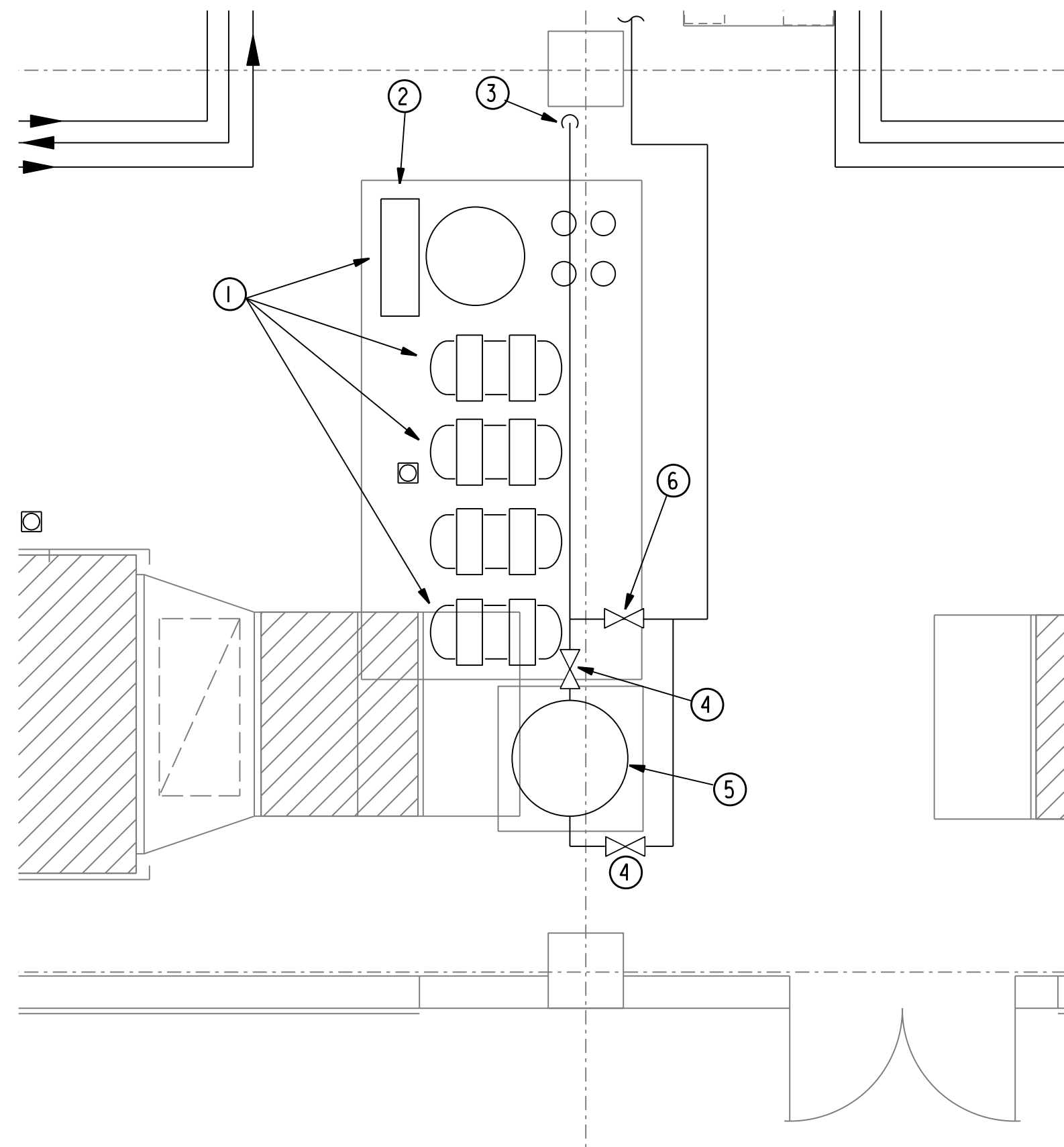

### 01 AIR COMPRESSOR DEMOLITION

SCALE: 1/4" = 1'-0"

**DEMOLITION PLAN NOTES:**

- ① REMOVE EXISTING AIR COMPRESSOR SYSTEM TO INCLUDE ALL PIPING AND SUPPORT EQUIPMENT. CLEAR AND CLEAN HOUSEKEEPING PAD FOR THE INSTALLATION OF THE NEW SYSTEM DURING RENOVATION.
- ② REMOVE/DISCONNECT POWER CONNECTION TO THE SYSTEM. CONFIRM IF POWER NEEDS TO BE UPGRADED FOR THE NEW SYSTEM.
- ③ REMOVE EXISTING SUPPLY PIPING CONNECTION TO MAIN SUPPLY TANK SERVICE OVERHEAD.
- ④ CLOSE EXISTING MAIN SHUT-OFF VALVES TO SUPPLY TANK.
- ⑤ BUILDING EXTRA SUPPLY TANK FOR COMPRESSED AIR SUPPLY TO REMAIN.
- ⑥ EXISTING BY PASS TO REMAIN. (VALVE IS NORMALLY CLOSED).

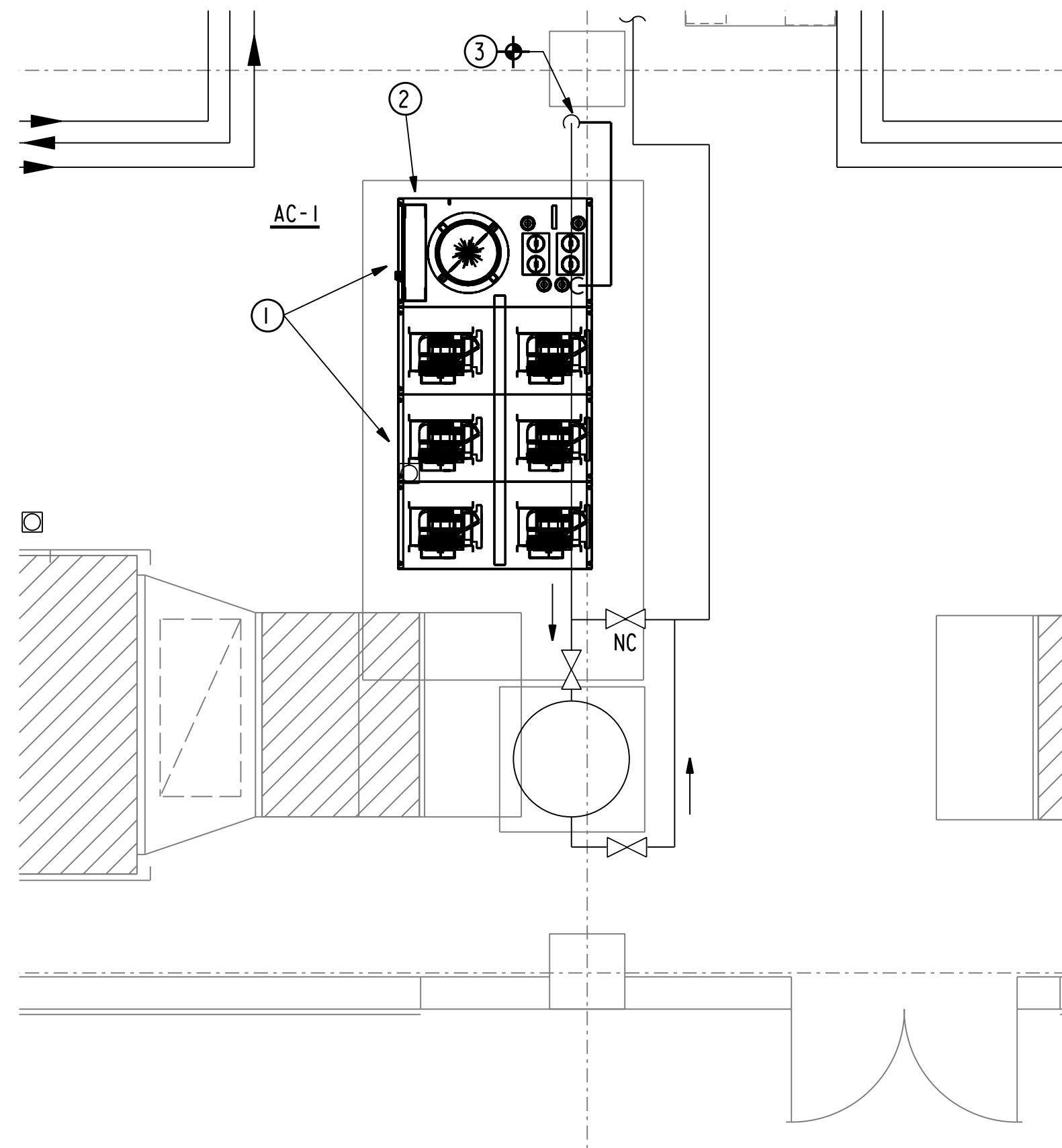

### 02 AIR COMPRESSOR RENOVATION

SCALE: 1/4" = 1'-0"

**RENOVATION PLAN NOTES:**

- ① INSTALL NEW AIR COMPRESSOR SYSTEM ON THE EXISTING HOUSEKEEPING PAD. ROUTE NEW DRAIN LINES TO THE NEAREST FLOOR SINK.
- ② CONNECT EXISTING POWER TO NEW AIR COMPRESSOR SYSTEM.
- ③ ROUTE NEW MAIN SUPPLY PIPING FROM SYSTEM AND CONNECT TO EXISTING MAIN SUPPLY DROP TO SERVE BUILDING.



### 03 EXISTING AIR COMPRESSOR

SCALE: NTS

### PLUMBING EQUIPMENT SCHEDULE

UNIT NO.	LOCATION	TYPE	TANK CAP. GAL.	DELIVERY PER TURBINE/COMPRESSOR		RPM	MOTOR			REMARKS
				SCFM	PRESS.		HP	VOLTS	PH	
AC-1	SOUTH PENTHOUSE	SCROLL	240	252 TOTAL	100 psi	1800	15	480	3	BEACON MEDAES MODEL NO. SAS15H-240V-HCD ** SPECIAL HEXAPLEX SYSTEM WITH SIX 15HP COMPRESSORS SYSTEM SHALL HAVE SINGLE POINT CONNECTIONS FOR ALL SERVICES. ALL INTERNAL PIPING, WIRING AND CONTROLS ARE INTEGRAL TO THE CONTROL PANEL FOR THE HEXAPLEX.

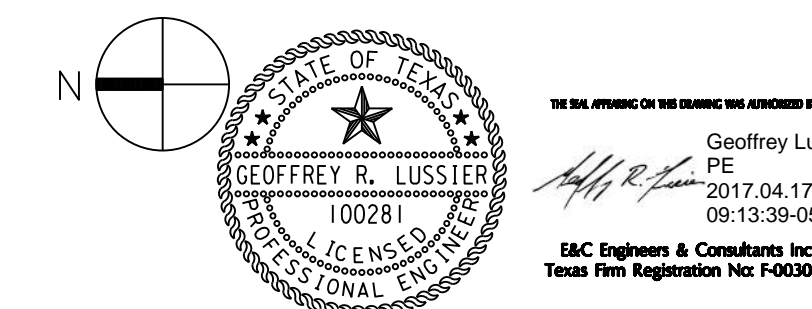

## E&C

Engineers & Consultants Inc.  
 TX Firm Registration No: F-003068  
 1010 Lamar, Suite 650  
 Houston, Texas 77002  
 Tel 713/580-8800  
 Fax 713/580-8888  
 www.eceng.com

## UTHSC-H MSB PENTHOUSE EQUIPMENT REPLACEMENT

E&C PROJECT # 3315

SKETCH: P105  
 DRAWING: PLUMBING SOUTH AIR COMPRESSOR  
 REVISION: 100%  
 SCALE: 1/4"=1'-0"  
 DATE: 04-17-2017



WATER HEATER SCHEDULE										
UNIT NO.	LOCATION	WATER				STEAM				REMARKS
		GPM	EWT	LWT	STORAGE	PRESSURE	STEAM LBS/HR			
SWH-1	NORTH PENTHOUSE	30	60	120	SEMI INSTANTANEOUS	15	1000			AERCO+ SWDW 24-1.50
SWH-2	NORTH PENTHOUSE	30	60	120	SEMI INSTANTANEOUS	15	1000			AERCO+ SWDW 24-1.50

- REFER TO MANUFACTURER'S RECOMMENDED INSTALLATION DOCUMENTATION FOR MULTIPLE HEATERS CONNECTED IN PARALLEL.
- CONNECT NEW CONTROL PANELS TO EXISTING POWER CIRCUITING MADE AVAILABLE BY REMOVING THE EXISTING HEATERS.
- THE COMMUNICATIONS PROTOCOL FOR THE WATER HEATERS IS TO BE BACNET.
- ALL CONTROL WIRING BETWEEN THE HEATERS AND LEAD/LAG PANEL SHALL BE ORDERED BY THE WATER HEATER SUPPLIER.

THE FOLLOWING READABLE POINTS ARE AVAILABLE FROM THE HEATERS:

1	HEATER NUMBER AND STATUS	ENABLE OR DISABLE
2	HEATER SET POINT	40 - 180 DEGREES F
3	HEADER TEMPERATURE	0 - 300 DEGREES F
4	HIGH HEADER TEMPERATURE	0 - 300 DEGREES F
5	LOW HEADER TEMPERATURE	0 - 300 DEGREES F
6	HEADER OUTLET TEMPERATURE	40 - 205 DEGREES F
7	OVER TEMPERATURE ALARM	NORMAL OR GOOD
8	SENSOR STATUS	GOOD OR FAILED

PUMP SCHEDULE													
PUMP NO.	LOCATION	SERVICE	TYPE	GPM	TOTAL HEAD FT. H <sub>2</sub> O	SHUT OFF HD FT. H <sub>2</sub> O	MAX. PRESS. PSI	MOTOR					MFR. AND MODEL NO. REMARKS
								BHP	HP	RPM	VOLTS @ 60 HZ	PH	
HWCP-1	NORTH PENTHOUSE	BUILDING HOT WATER CIRCULATING PUMP	IN-LINE CENTRIFUGAL	20	20	--	174	--	276 WATT	1750	120	1	GRUNDFOS+ MAGNA3 40-80 FN
HWCP-2	NORTH PENTHOUSE	BUILDING HOT WATER CIRCULATING PUMP	IN-LINE CENTRIFUGAL	20	20	--	174	--	276 WATT	1750	120	1	GRUNDFOS+ MAGNA3 40-80 FN

NOTES: PROVIDE THE WATER HEATER CONTROL PANEL / LEAD LAG CONTROL PANEL WITH POWER REDUCING TRANSFORMER TO SERVE ALL OF THE EQUIPMENT IN THE NEW HOT WATER SUPPLY SYSTEM. THUS, ALLOWING THE COMPLETE PACKAGE TO BE SERVED WITH THE EXISTING 480 VAC/3 PHASE POWER CIRCUIT.

#### WATER HEATER SEQUENCE OF OPERATION

THE SEQUENCING CONTROL PANEL PROVIDES LEAD-LAG SEQUENCING/ALTERNATION OF THE TWO WATER HEATERS BASED ON THE HOT WATER HEADER TEMPERATURE AND AUTOMATIC ALTERNATION OF THE LEAD HEATER. THE HEATERS ARE ENABLED ON AND OFF BY A DIGITAL INPUT ON THE HEATER CONTROL PANEL AND BY OPERATING A MOTOR OPERATED ISOLATION VALVE ON THE DISCHARGE PIPING OF EACH HEATER. THE CONTROL INPUT TO THE SEQUENCING PANEL IS THE TEMPERATURE OF THE HOT WATER HEADER. THE AUTO-SEQUENCING PANEL INCORPORATES AN HMI SCREEN THAT DISPLAYS:

HEADER TEMPERATURE HEATER STATUS & SYSTEM ALARMS  
LAG HEATER SEQUENCE TEMPERATURE SET POINT (OPERATOR SETTABLE)  
HIGH AND LOW TEMPERATURE SET POINT (OPERATOR SETTABLE)  
LEAD HEATER SELECTION  
LEAD HEATER ALTERNATION TIME PERIOD (OPERATOR SETTABLE)

WHEN A HEATER IS ENABLED, THE TEMPERATURE CONTROLLER MODULATES THE ELECTRONIC STEAM CONTROL VALVE TO MAINTAIN THE SYSTEM'S HOT WATER TEMPERATURE. (OPERATOR SETTABLE) WHEN THE HOT WATER HEADER TEMPERATURE FALLS BELOW THE SYSTEMS LOW TEMPERATURE SET POINT AND REMAINS BELOW THE SET POINT, THE LOW SYSTEM TEMPERATURE ALARM WILL BE ACTUATED AND THE LAG HEATER WILL BE ENABLED. THE LAG HEATER WILL REMAIN ENABLED UNTIL THE ALARM IS ACKNOWLEDGED AND THE OPERATOR HAS CORRECTED THE CAUSE OF THE CONDITION.

WHEN THE HOT WATER TEMPERATURE RISES ABOVE THE HIGH SYSTEM TEMPERATURE SET POINT, THE HIGH SYSTEM TEMPERATURE ALARM WILL BE ACTUATED. THE CURRENT LEAD HEATER WILL BE DISABLED AND THE LAG HEATER WILL BE ENABLED AS THE LEAD HEATER. THE DISABLED HEATER WILL REMAIN OUT OF SERVICE UNTIL THE HIGH SYSTEM TEMPERATURE ALARM IS ACKNOWLEDGED AND THE OPERATOR HAS CORRECTED THE CAUSE OF THE CONDITION.

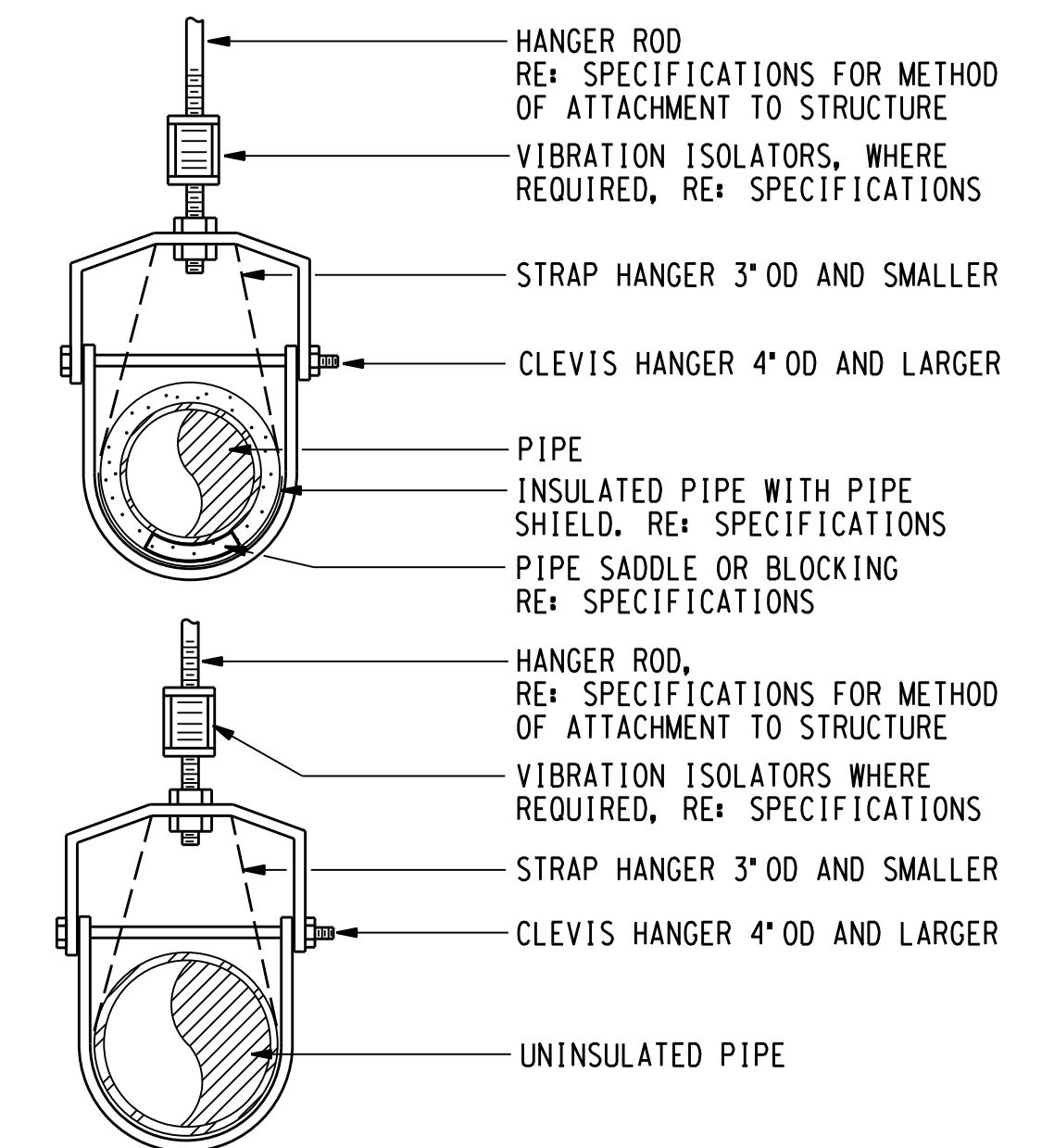

## 01 TYPICAL SINGLE PIPE HANGER

NOT TO SCALE

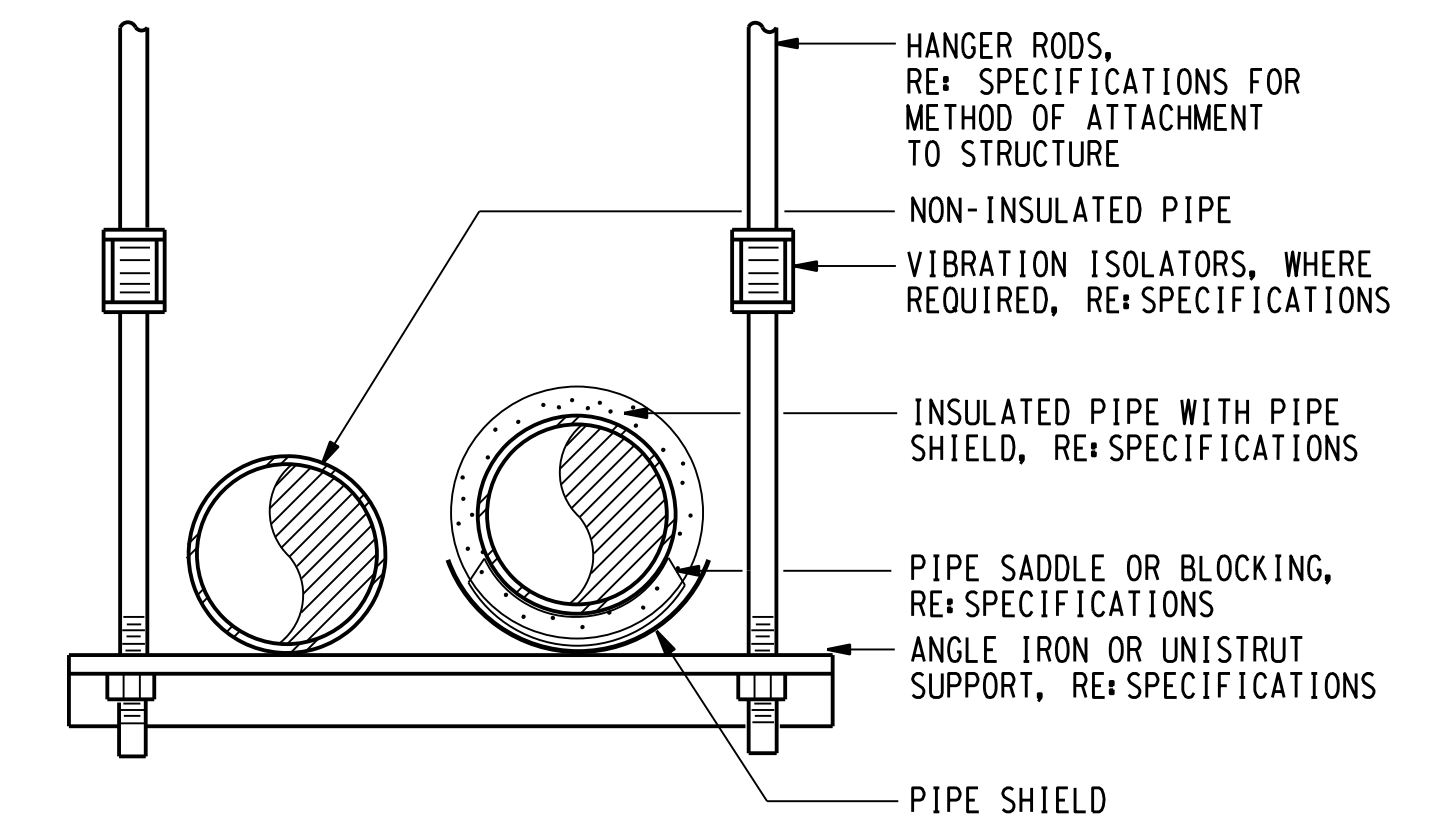

## 02 TYPICAL TRAPEZE TYPE MULTIPLE PIPE HANGER

NOT TO SCALE

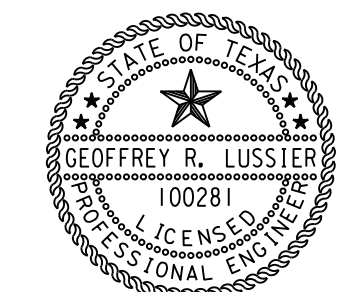

Geoffrey Lussier,  
PE  
2017.04.17  
09:13:38-05'00"  
E&C Engineers & Consultants Inc.  
Texas Firm Registration No. F-003068

# E&C

Engineers & Consultants Inc.  
TX Firm Registration No: F-003068  
1010 Lamar, Suite 650  
Houston, Texas 77002  
Tel 713/580-8800  
Fax 713/580-8888  
www.eceng.com

## UTHSC-H MSB PENTHOUSE EQUIPMENT REPLACEMENT

E&C PROJECT # 3315

SKETCH: P301

DRAWING: PLUMBING  
DETAILS AND  
SCHEDULES

REVISION: 100%

SCALE: NONE

DATE: 04-17-2017



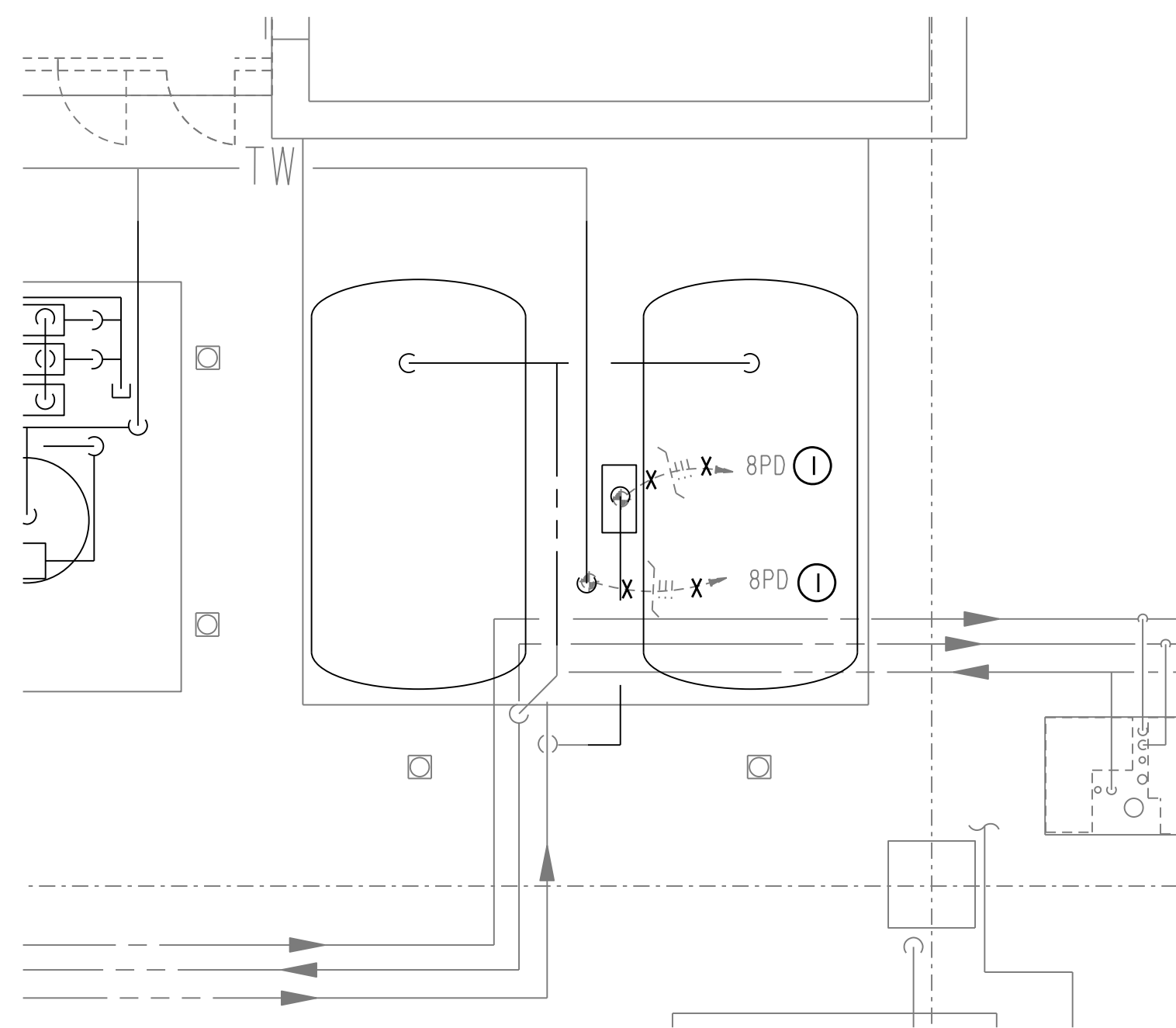

**01** WATER HEATERS SYSTEM -  
DEMOLITION - SOUTH SIDE  
SCALE: 1/4" = 1' - 0"

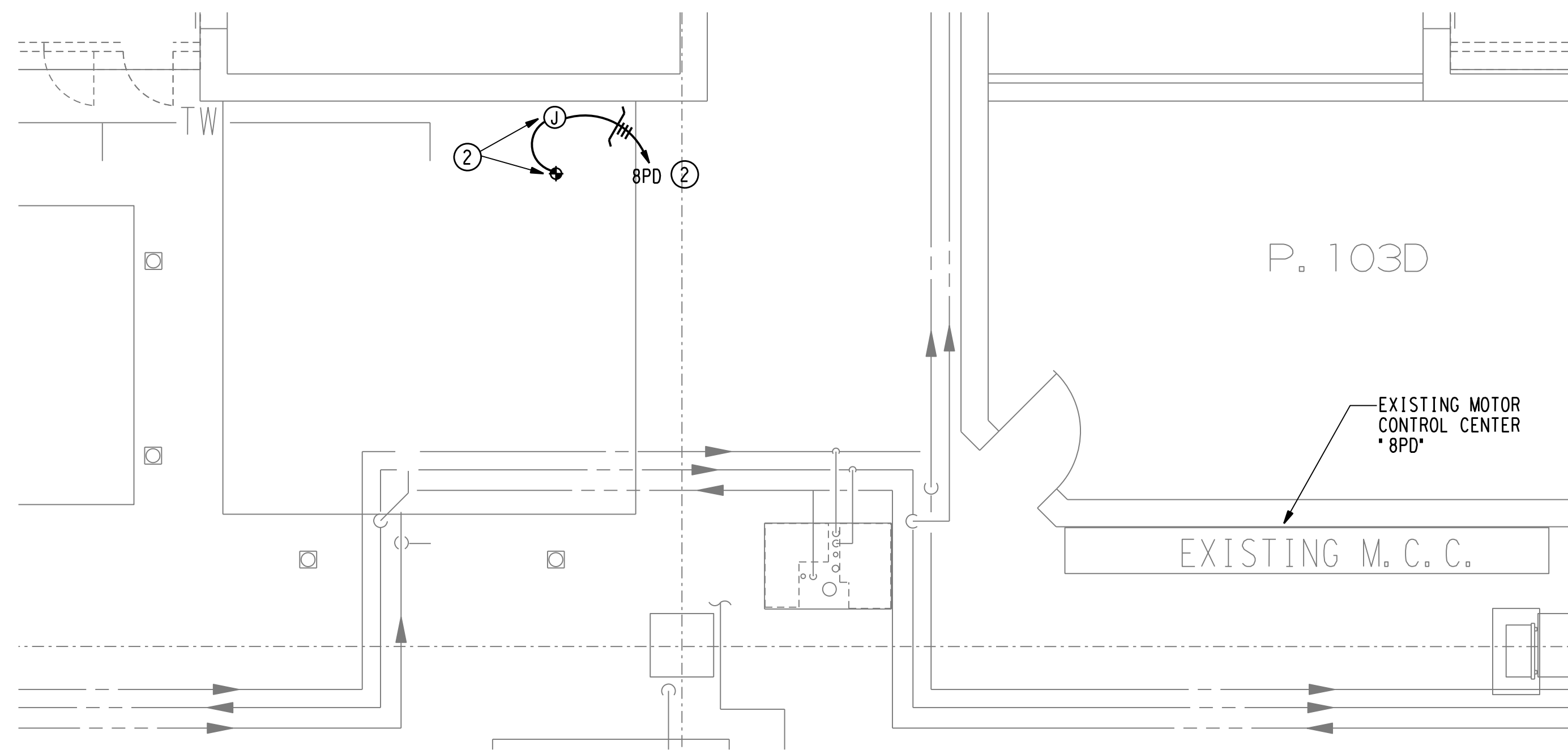

**02** WATER HEATERS SYSTEM -  
RENOVATION - SOUTH SIDE  
SCALE: 1/4" = 1' - 0"

**DRAWING NOTES:**

- ① EXISTING CIRCULATION PUMP TO BE REMOVED. PUMPS ARE CIRCUITED TO EXISTING MOTOR CONTROL CENTER 8PD ADJACENT TO THE WATER HEATER. REMOVE FEEDERS FROM MCC TO PUMP. ONE PUMP IS LABELED HWC-8/3 AND ONE PUMP IS LABELED HWC-8/4 AT THE MCC. MCC CUBICLE FOR HWC-8/3 SHALL BE REUSED SEE NOTE 2. MCC CUBICLE FOR HWC-8/4 SHALL BE SPARED.
- ② EXTEND EXISTING 480V CIRCUIT TO SERVE NEW LEAD/LAG CONTROL PANEL AND ASSOCIATED PUMPS AND HEATERS. COORDINATE REQUIREMENTS WITH MANUFACTURER AND PROVIDE ALL COMPONENTS FOR A COMPLETE SYSTEM. MODIFY MCC CUBICLE MARKED \*HWC-8/3\* TO CONVERT STARTER/DISCONNECT TO 20A/3P CIRCUIT BREAKER. PROVIDE A NEW BREAKER/BUCKET IN THE 12" CUBICLE WITH A 20A/3P CIRCUIT BREAKER. BREAKER SHALL BE RATED FOR 42,000 AIC. LABEL CUBICLE \*HWG-3, 4\*. PROVIDE 3" 12, #12G, 3/4" C AS REQUIRED BETWEEN MCC AND HOT WATER SKID.

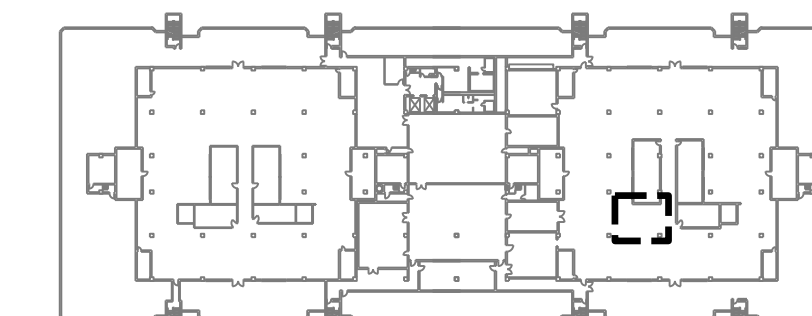

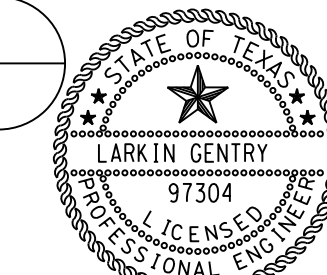

  
 LARKIN GENTRY  
 713.580.8833  
 2017.04.17  
 09-33-00-05'00"  
 E&C Engineers & Consultants Inc.  
 Texas Firm Registration No: F-003068

**E&C**  
 Engineers & Consultants Inc.  
 TX Firm Registration No: F-003068  
 1010 Lamar, Suite 650  
 Houston, Texas 77002  
 Tel 713/580-8800  
 Fax 713/580-8888  
 www.eceng.com

**UTHSC-H**  
**MSB PENTHOUSE EQUIPMENT REPLACEMENT**

E&C PROJECT # 3315

SKETCH: E101  
 DRAWING: ELECTRICAL  
 SOUTH WATER  
 HEATER  
 REVISION: 100%  
 SCALE: 1/4"=1'-0"  
 DATE: 04-17-2017



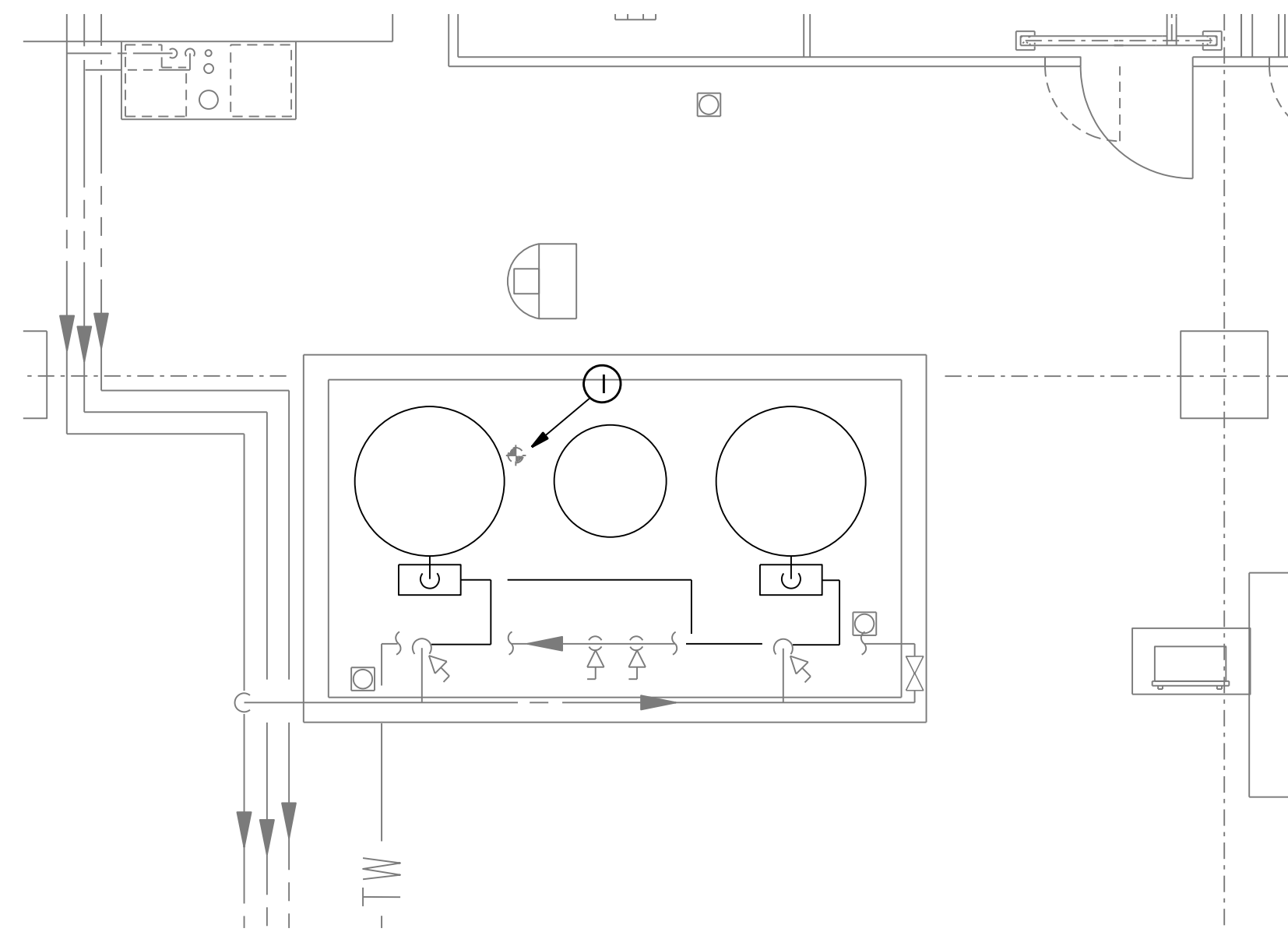

**01** WATER SOFTNER SYSTEM  
DEMOLITION PLAN - SOUTH SIDE  
SCALE: 1/4"=1'-0"

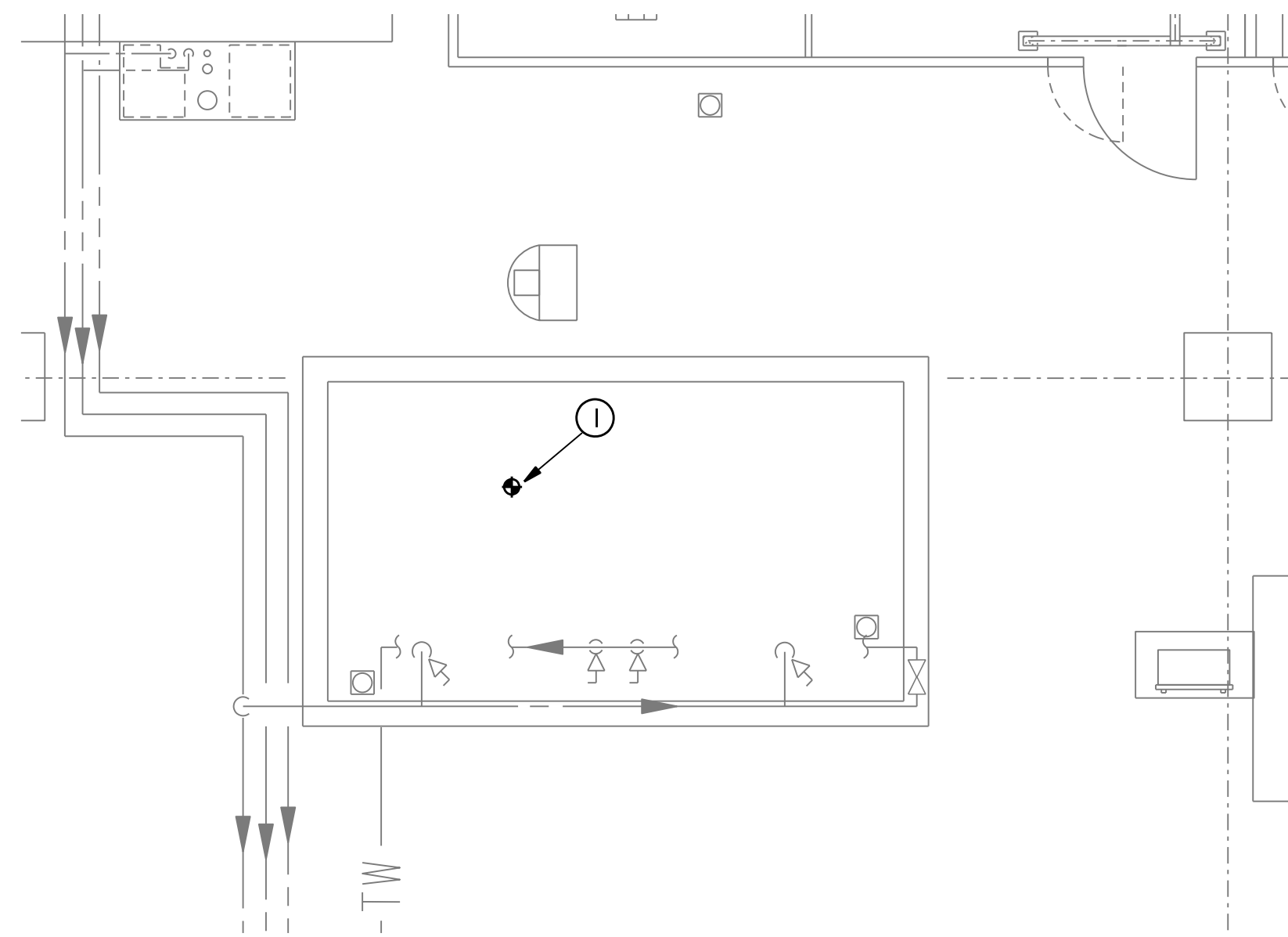

**02** WATER SOFTNER SYSTEM  
RENOVATION PLAN - SOUTH SIDE  
SCALE: 1/4"=1'-0"

**DRAWING NOTES:**

- ① EXISTING 120V CONTROL POWER TO WATER SOFTNER TO REMAIN. TEMPORARILY DISCONNECT POWER TO WATER SOFTNER CONTROLS AND RECONNECT WHEN NEW CONTROLS ARE INSTALLED.

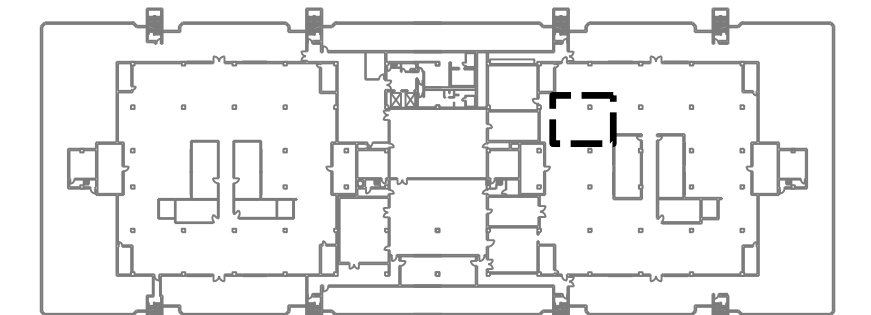



 Larkin Gentry  
 Houston, TX  
 713.580.8833  
 2017.04.17  
 09:33:00-05'00"  
 E&C Engineers & Consultants Inc.  
 Texas Firm Registration No: F-003068

**E&C**  
 Engineers & Consultants Inc.  
 TX Firm Registration No: F-003068  
 1010 Lamar, Suite 650  
 Houston, Texas 77002  
 Tel 713/580-8800  
 Fax 713/580-8888  
 www.eceng.com

**UTHSC-H**  
**MSB PENTHOUSE EQUIPMENT REPLACEMENT**

E&C PROJECT # 3315

SKETCH: E102  
 DRAWING: ELECTRICAL  
 SOUTH WATER  
 SOFTENERS  
 REVISION: 100%  
 SCALE: 1/4"=1'-0"  
 DATE: 04-17-2017



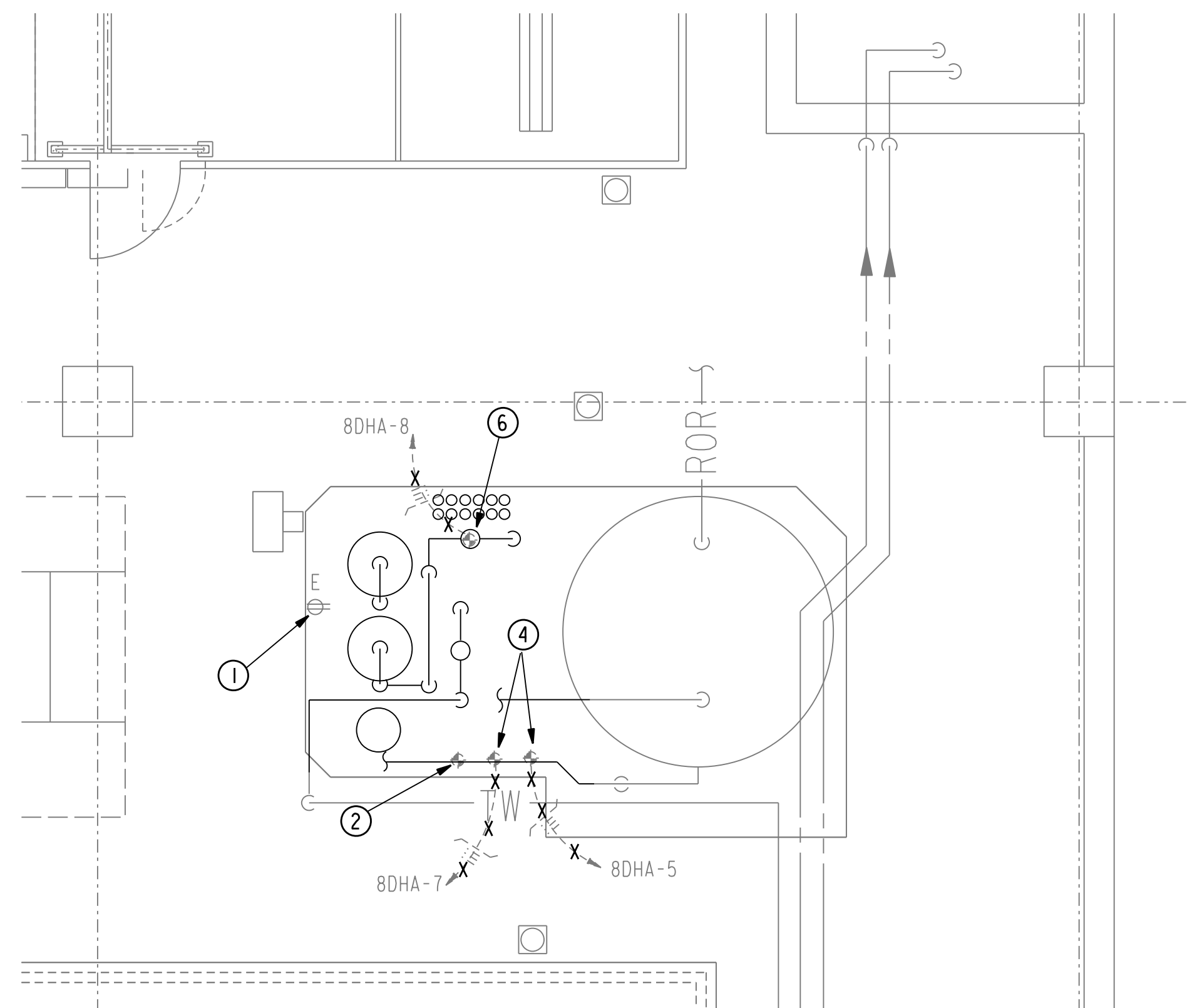

**01** REVERSE OSMOSIS SYSTEM -  
DEMOLITION - NORTH SIDE  
SCALE: 1/4" = 1' - 0"

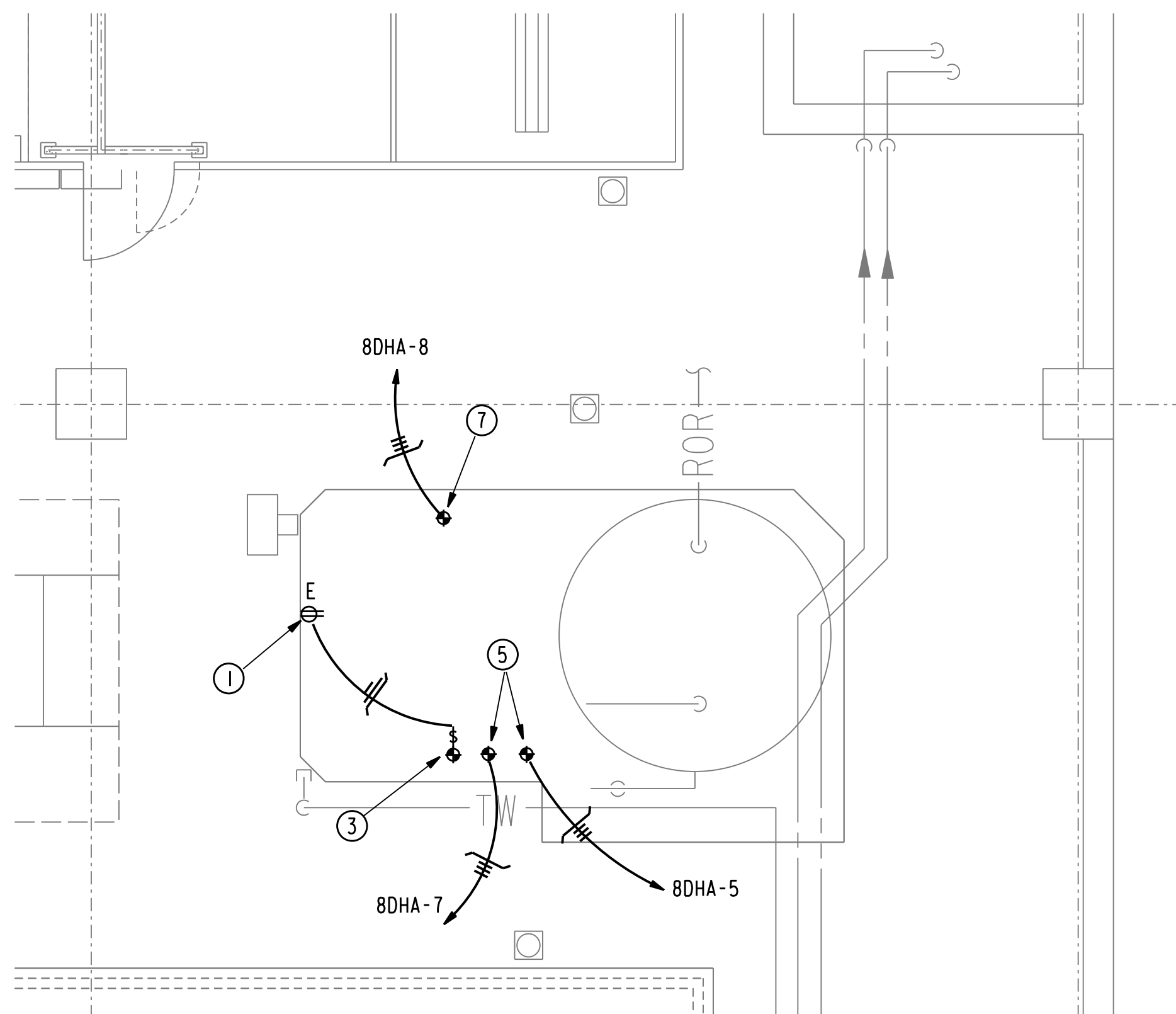

**02** REVERSE OSMOSIS SYSTEM -  
RENOVATION - NORTH SIDE  
SCALE: 1/4" = 1' - 0"

**DRAWING NOTES:**

- ① EXISTING DUPLEX RECEPTACLE UNISTRUT MOUNTED ABOVE FLOOR FOR CONTROL POWER TO RO FILTERS TO REMAIN AND BE REUSED. RECEPTACLE CIRCUITED TO PANEL 8LA. FIELD VERIFY EXACT CIRCUIT SERVING RECEPTACLE AND MARK ON RECEPTACLE COVERPLATE.
- ② EXISTING CONNECTION EXISTING UV LIGHT TO BE REMOVED. RECIRCUIT NEW UV LIGHT AS SHOWN ON THE RENOVATION PLAN.
- ③ EXTEND EXISTING 120V CIRCUIT SERVING RO FILTERS TO SERVE NEW UV LIGHT. PROVIDE UV LIGHT WITH 120V, 1P, 20A TOGGLE SWITCH DISCONNECT MOUNTED TO RO SKID.
- ④ CONNECTION TO CONTROL PANEL AND RO CIRCULATION PUMPS WITH CIRCUITS SHOWN. TEMPORARILY DISCONNECT POWER TO PUMPS AND RECONNECT AS SHOWN ON THE RENOVATION PLAN.
- ⑤ MAKE CONNECTION TO DUAL FEED CONTROL PANEL WITH INTEGRAL DISCONNECTS FOR RO CIRCULATION PUMPS. CIRCUIT 7 SHALL SERVE ONE PUMP AND CIRCUIT 5 SHALL SERVE THE OTHER PUMP. BOTH PUMPS ARE SERVED FROM PANEL 8DHA VIA 15A/3P CIRCUIT BREAKERS. EXTEND 3"12, #12G, 3/4" C AS NEEDED TO EXTEND EXISTING CIRCUIT TO NEW CONTROL PANEL LOCATION.
- ⑥ CONNECTION TO CONTROL PANEL AND RO FILTER PUMP WITH CIRCUIT SHOWN. TEMPORARILY DISCONNECT POWER TO PUMP AND RECONNECT AS SHOWN ON THE RENOVATION PLAN.
- ⑦ MAKE CONNECTION TO SINGLE FEED CONTROL PANEL FOR RO FILTER PUMP WITH INTEGRAL DISCONNECT. REUSE EXISTING CIRCUIT SHOWN TO SERVE NEW PUMP. REMOVE EXISTING 30A/3P CIRCUIT BREAKER IN PANEL 8DHA AND REPLACE WITH NEW 15A/3P CIRCUIT BREAKER TO SERVE NEW MOTOR. NEW CIRCUIT BREAKER SHALL MATCH EXISTING PANEL BRACING. EXTEND 3"12, #12G, 3/4" C AS NEEDED TO EXTEND EXISTING CIRCUIT TO NEW CONTROL PANEL LOCATION.

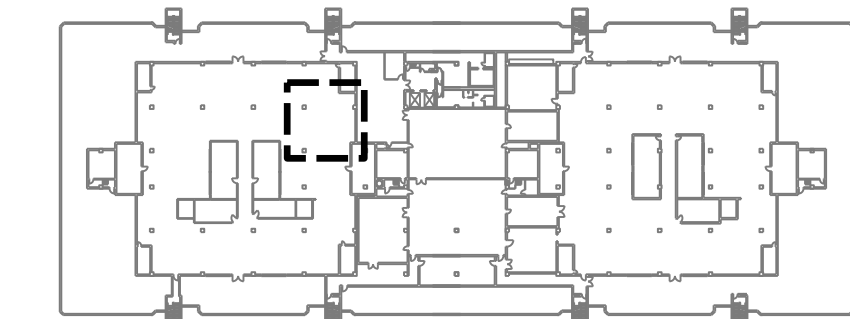

N

Larkin Gentry  
 Houston, TX  
 713.580.8833  
 2017.04.17  
 09-33-00-05'00"  
 E&C Engineers & Consultants Inc.  
 Texas Firm Registration No: F-003068

**E&C**  
 Engineers & Consultants Inc.  
 TX Firm Registration No: F-003068  
 1010 Lamar, Suite 650  
 Houston, Texas 77002  
 Tel 713/580-8800  
 Fax 713/580-8888  
 www.eceng.com

**UTHSC-H**  
**MSB PENTHOUSE EQUIPMENT REPLACEMENT**

E&C PROJECT # 3315

SKETCH: E103  
 DRAWING: ELECTRICAL  
 NORTH REVERSE  
 OSMSIS  
 REVISION: 100%  
 SCALE: 1/4"=1'-0"  
 DATE: 04-17-2017

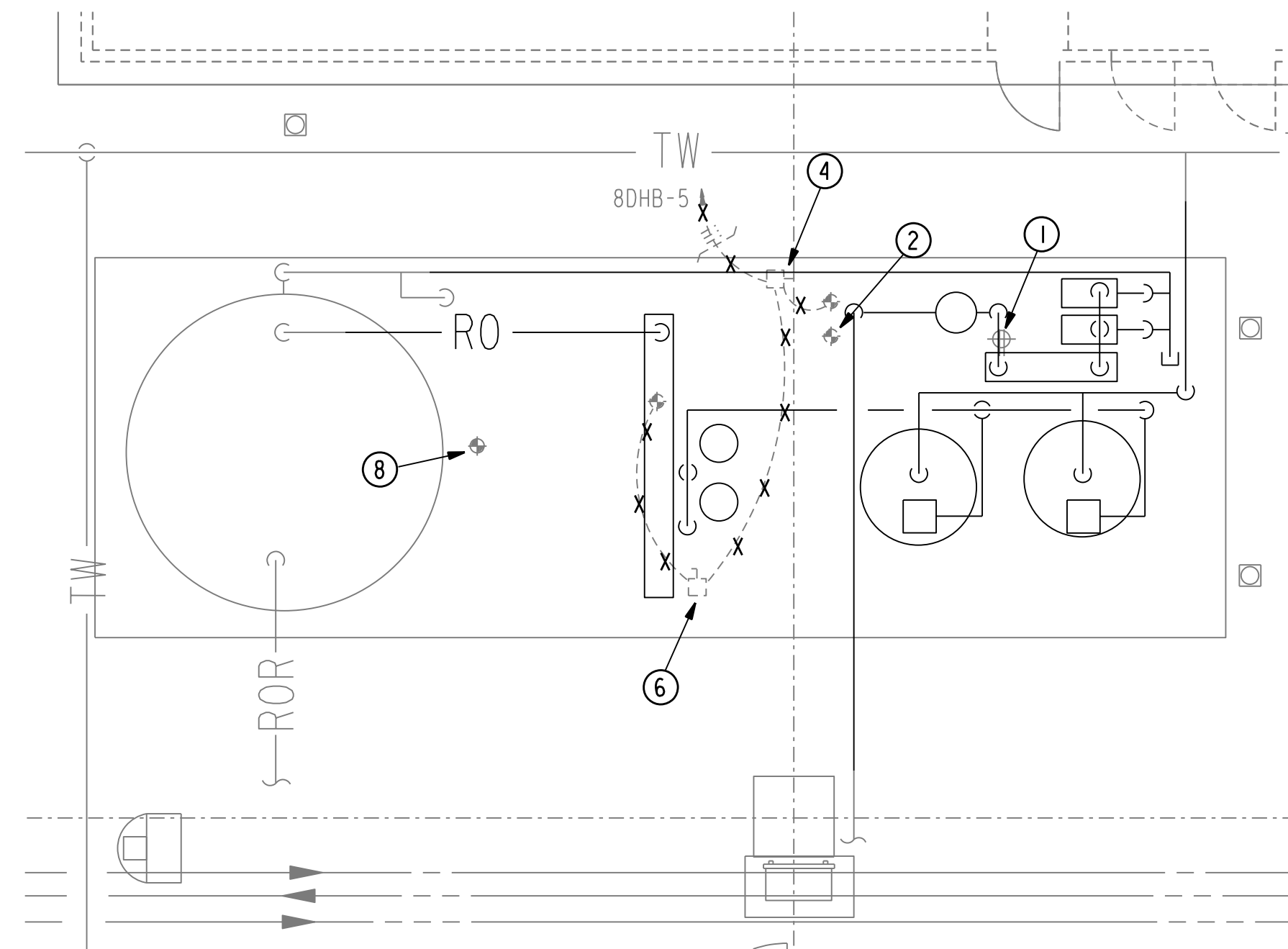

**01** REVERSE OSMOSIS SYSTEM -  
DEMOLITION - SOUTH SIDE  
SCALE: 1/4" = 1' - 0"

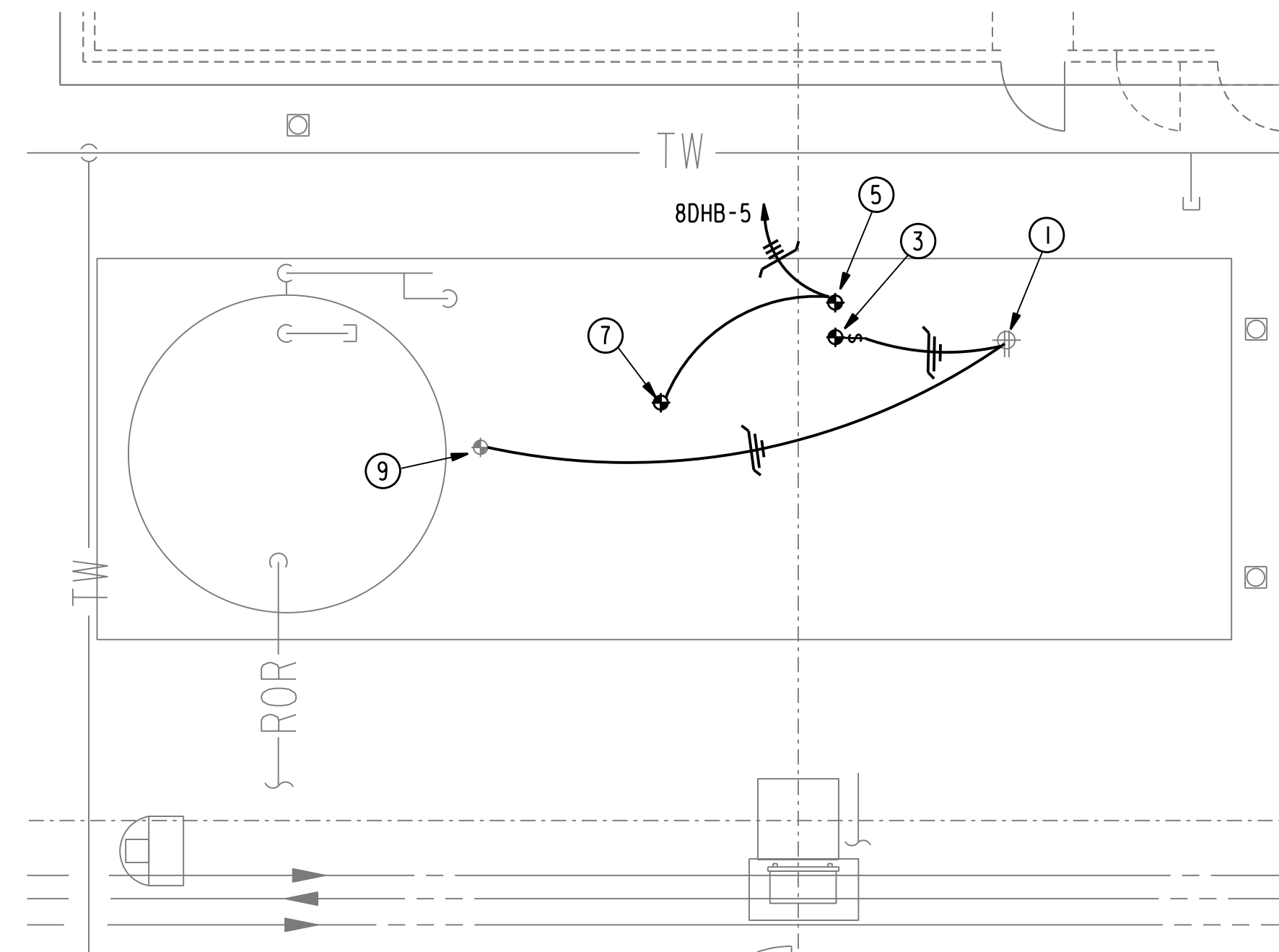

**02** REVERSE OSMOSIS SYSTEM -  
DEMOLITION - SOUTH SIDE  
SCALE: 1/4" = 1' - 0"

**DRAWING NOTES:**

- ① EXISTING QUAD RECEPTACLE UNISTRUT MOUNTED ABOVE FLOOR FOR CONTROL POWER TO RO FILTERS TO REMAIN AND BE REUSED. RECEPTACLE CIRCUITED TO PANEL 8LB CIRCUIT 34. FIELD VERIFY EXACT CIRCUIT SERVING RECEPTACLE AND MARK ON RECEPTACLE COVERPLATE.
- ② EXISTING CONNECTION EXISTING UV LIGHT TO BE REMOVED. RECIRCUIT NEW UV LIGHT AS SHOWN ON THE RENOVATION PLAN.
- ③ EXTEND EXISTING 120V CIRCUIT SERVING RO FILTERS TO SERVE NEW UV LIGHT. PROVIDE UV LIGHT WITH 120V, 1P, 20A TOGGLE SWITCH DISCONNECT MOUNTED TO RO SKID.
- ④ CONNECTION TO CONTROL PANEL AND RO CIRCULATION PUMPS WITH CIRCUIT SHOWN. TEMPORARILY DISCONNECT POWER TO PUMPS AND RECONNECT AS SHOWN ON THE RENOVATION PLAN.
- ⑤ MAKE CONNECTION TO SINGLE FEED CONTROL PANEL WITH INTEGRAL DISCONNECTS FOR RO CIRCULATION PUMPS. REMOVE EXISTING 100A/3P CIRCUIT BREAKER AT 8DHB-5 AND REPLACE WITH ONE 15A/3P CIRCUIT BREAKER. NEW BREAKER SHALL MATCH EXISTING PANEL BRACING. EXTEND 3\*12, #12G, 3/4" C FROM PANEL TO SKID AND AS NEEDED BETWEEN CONTROL PANEL AND PUMPS. TAP FROM BRANCH CIRCUIT SHALL BE LESS THAN 10 FEET.
- ⑥ CONNECTION TO CONTROL PANEL AND RO FILTER PUMP WITH CIRCUIT SHOWN. REMOVE BRANCH CIRCUIT AND DISCONNECT. REUSE CIRCUIT AS SHOWN ON ALTERATION PLAN.
- ⑦ MAKE CONNECTION TO SINGLE FEED CONTROL PANEL FOR RO FILTER PUMP WITH INTEGRAL DISCONNECT. REUSE EXISTING CIRCUIT SHOWN TO SERVE NEW PUMP. EXTEND 3\*12, #12G, 3/4" C FROM BRANCH CIRCUIT TO SKID AND AS NEEDED BETWEEN CONTROL PANEL AND PUMP. TAP FROM BRANCH CIRCUIT SHALL BE LESS THAN 10 FEET.
- ⑧ EXISTING LOW LEVEL WATER ALARM TO REMAIN. DISCONNECT FROM POWER AND RECONNECT AS SHOWN ON ALTERATION PLAN.
- ⑨ RECONNECT LOW LEVEL WATER ALARM AS SHOWN. EXTEND 2\*12, #12G, 3/4" C AS REQUIRED.

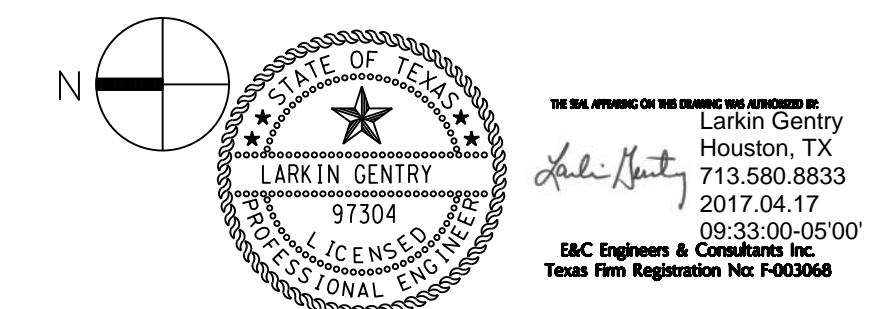
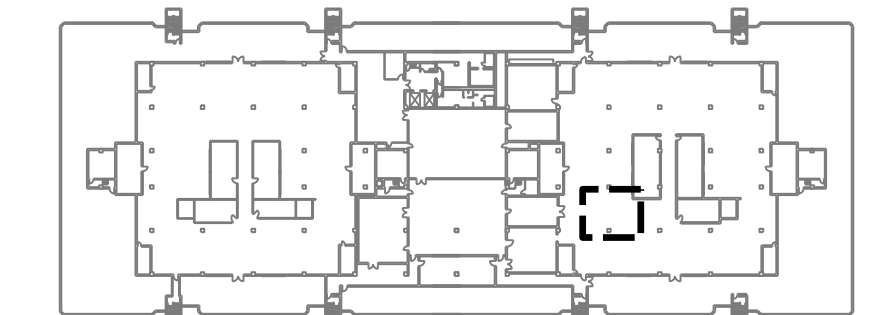

**E&C**  
Engineers & Consultants Inc.  
TX Firm Registration No: F-003068  
1010 Lamar, Suite 650  
Houston, Texas 77002  
Tel 713/580-8800  
Fax 713/580-8888  
www.eceng.com

**UTHSC-H**  
**MSB PENTHOUSE EQUIPMENT REPLACEMENT**

E&C PROJECT # 3315

SKETCH: E104  
DRAWING: ELECTRICAL SOUTH REVERSE OSMOSIS  
REVISION: 100%  
SCALE: 1/4"=1'-0"  
DATE: 04-17-2017



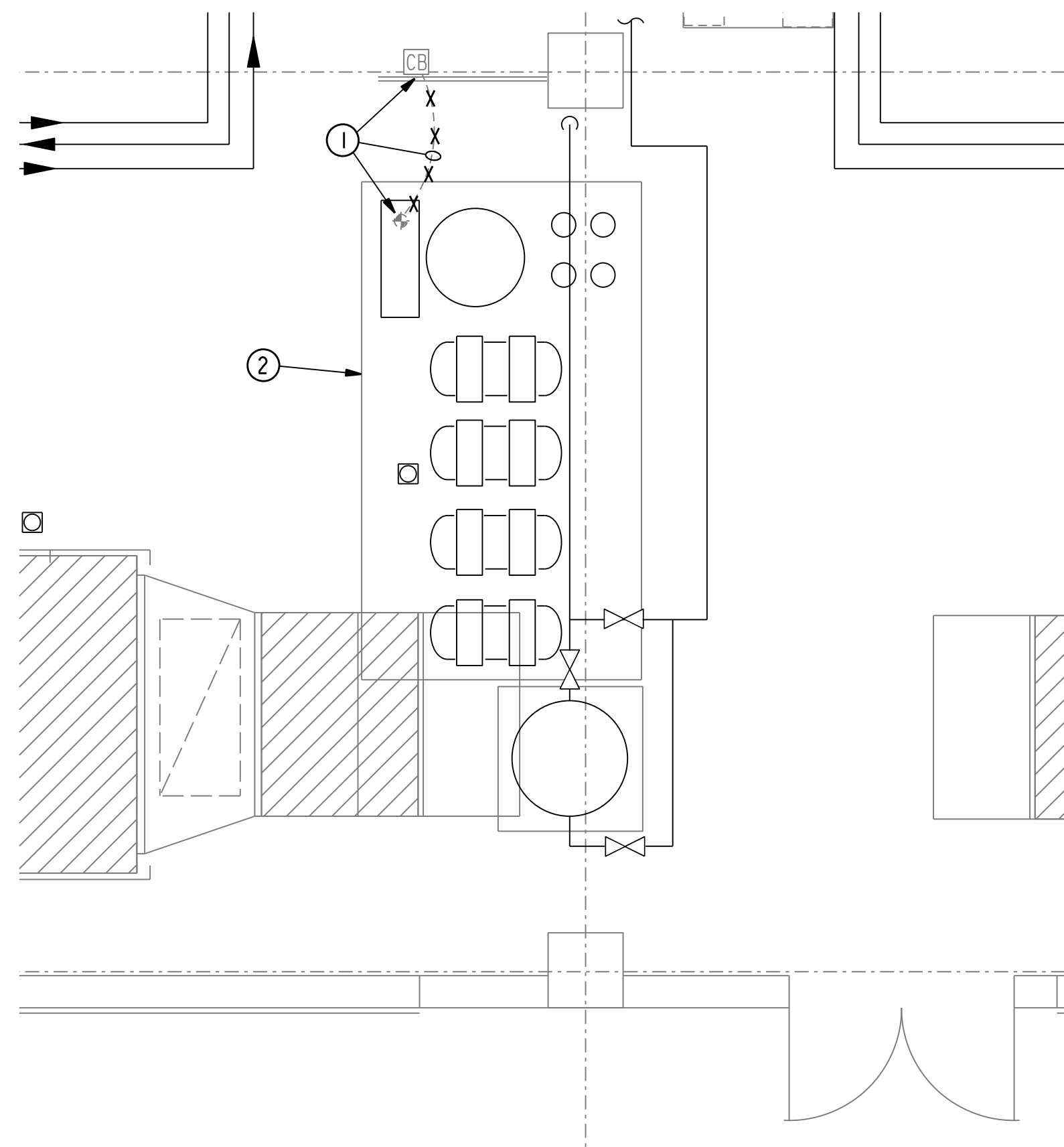

**01 AIR COMPRESSOR DEMOLITION**  
SCALE: 1/4" = 1' - 0"

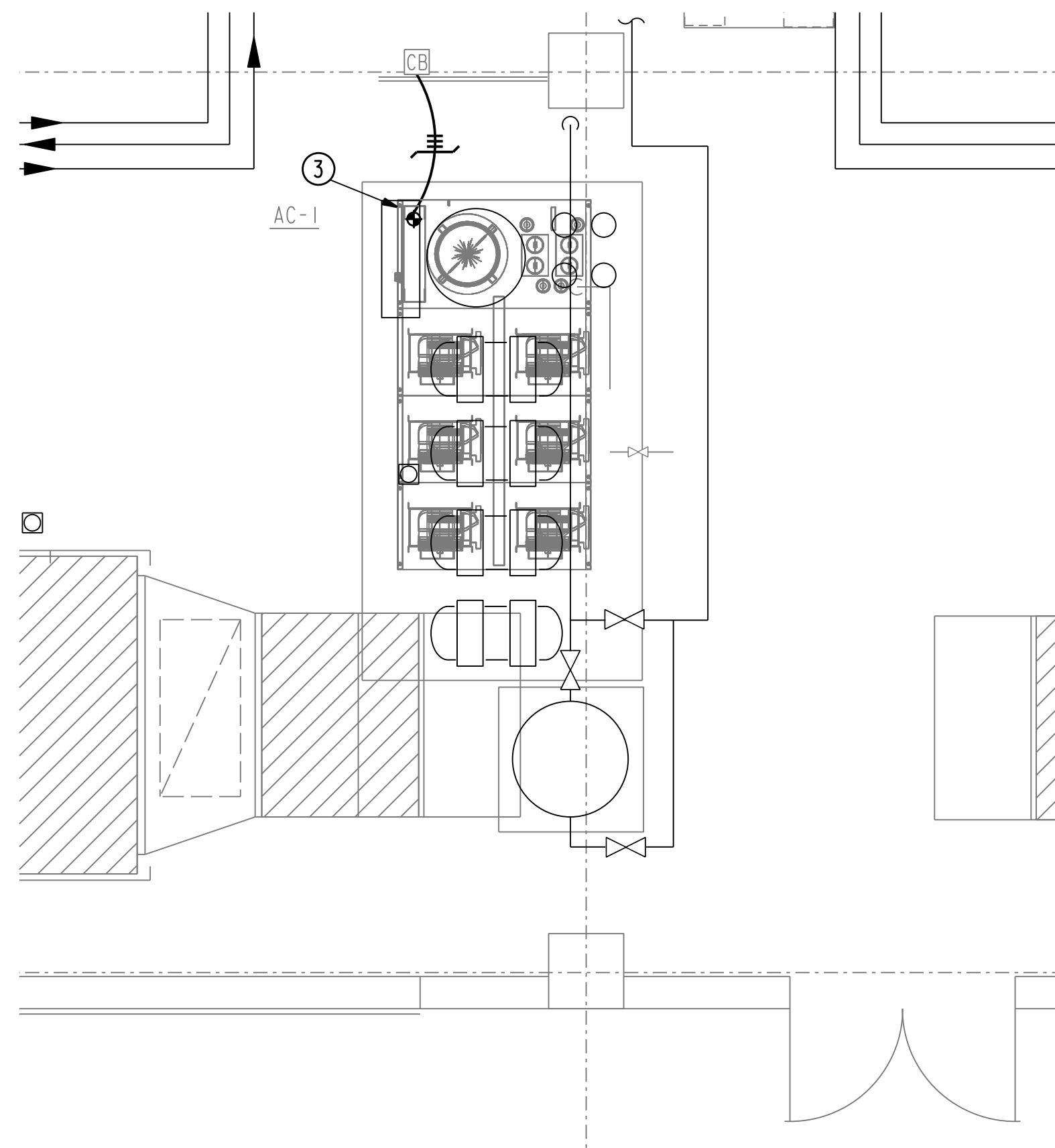

**02 AIR COMPRESSOR RENOVATION**  
SCALE: 1/4" = 1' - 0"

**DRAWING NOTES:**

- ① EXISTING 150A/3P UNISTRUT RACK MOUNTED CIRCUIT BREAKER SUPPLIED FROM 8DHB-3 TO REMAIN. TURN BREAKER OFF AND REMOVE BRANCH CIRCUIT BETWEEN CIRCUIT BREAKER AND AIR COMPRESSOR CONTROL PANEL.
- ② EXISTING MEDICAL AIR COMPRESSOR TO BE REMOVED BY PLUMBING CONTRACTOR. COORDINATE DISCONNECT OF ELECTRICAL POWER WITH PLUMBING CONTRACTOR.
- ③ EXTEND 3" 1/0, #6G, 2" C FROM EXISTING 150A/3P RACK MOUNTED CIRCUIT BREAKER TO NEW MEDICAL AIR COMPRESSOR CONTROL PANEL. PANEL HAS INTEGRAL DISCONNECTS WITH CONTROLS AND A SINGLE POINT ELECTRICAL CONNECTION.

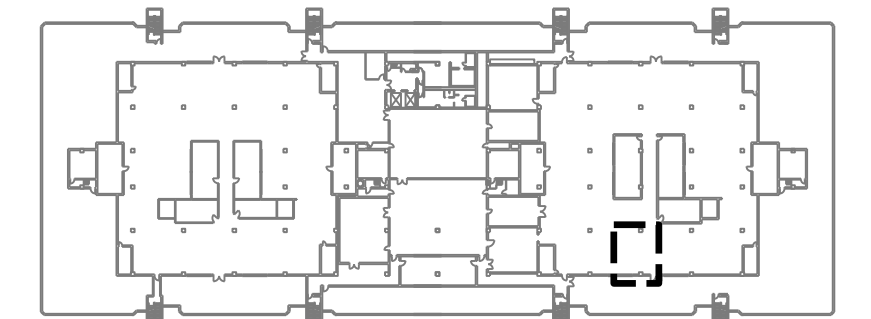



  
 Larkin Gentry  
 Houston, TX  
 713.580.8833  
 2017.04.17  
 09-33-00-05'00"  
 E&C Engineers & Consultants Inc.  
 Texas Firm Registration No: F-003068

**E&C**  
 Engineers & Consultants Inc.  
 TX Firm Registration No: F-003068  
 1010 Lamar, Suite 650  
 Houston, Texas 77002  
 Tel 713/580-8800  
 Fax 713/580-8888  
 www.eceng.com

**UTHSC-H  
 MSB PENTHOUSE EQUIPMENT REPLACEMENT**

E&C PROJECT # 3315

SKETCH: E105  
 DRAWING: ELECTRICAL SOUTH AIR COMPRESSORS  
 REVISION: 100%  
 SCALE: 1/4"=1'-0"  
 DATE: 04-17-2017

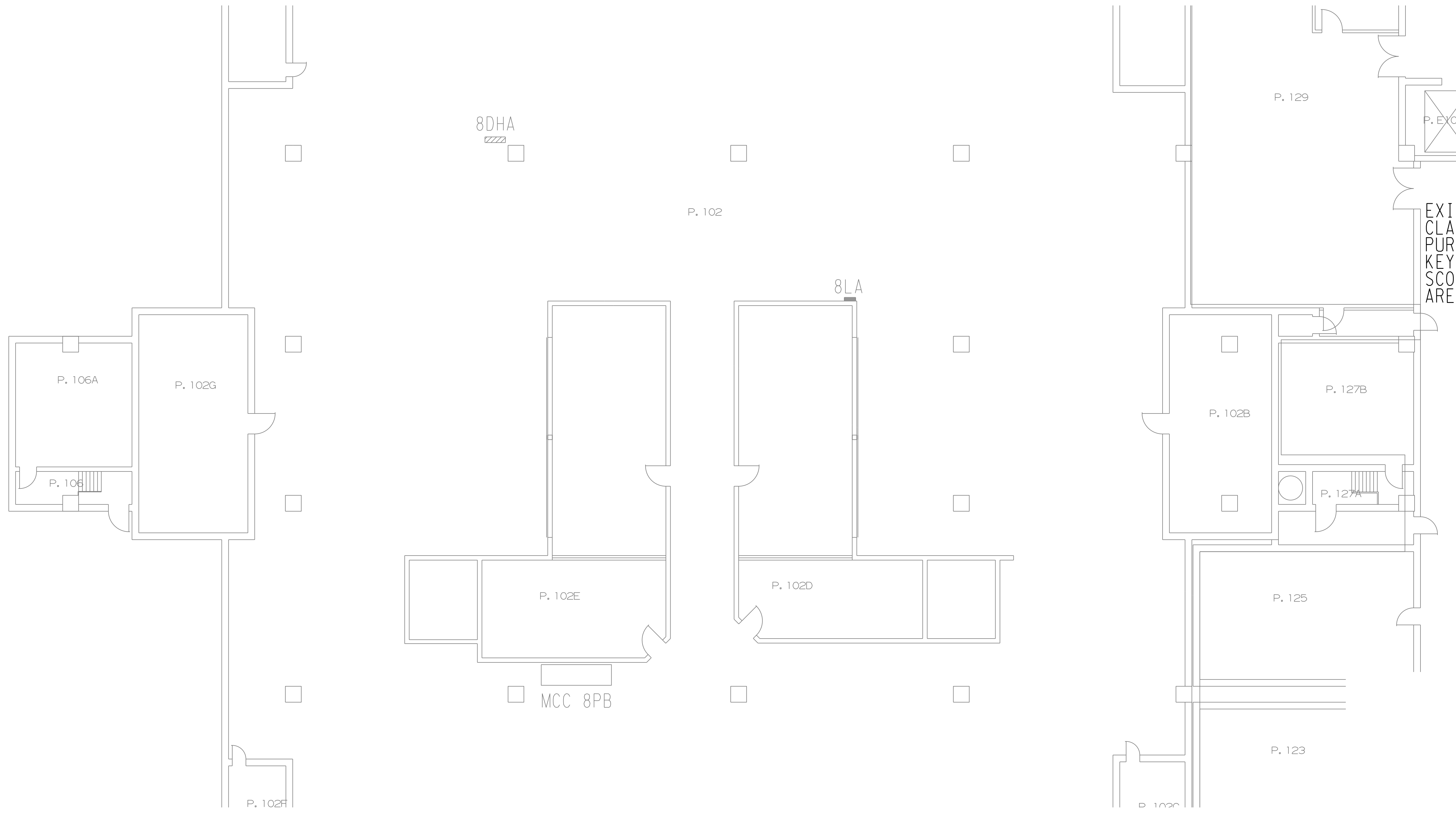

EXISTING PANELS ARE SHOWN FOR CLARIFICATION AND INFORMATION PURPOSES. REFER TO INDIVIDUAL KEY PLANS FOR APPROXIMATE SCOPE OF WORK. ALL LOCATIONS ARE APPROXIMATE.

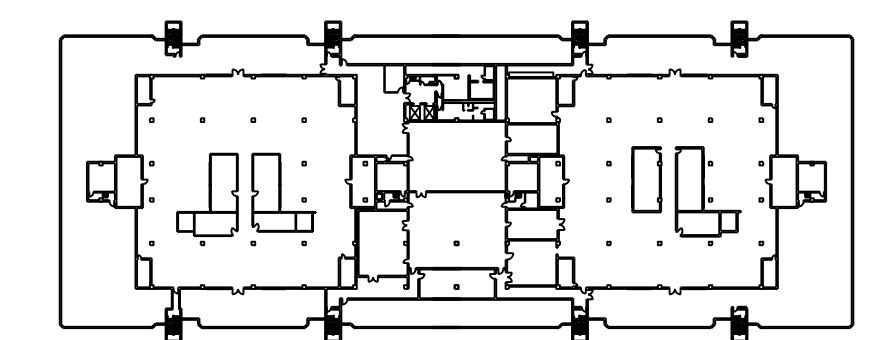

**01 ELECTRICAL PENTHOUSE PLAN**  
 SCALE: 1/8" = 1'-0"

N

LARKIN GENTRY  
 97304  
 LICENSED PROFESSIONAL ENGINEER

Larkin Gentry  
 Houston, TX  
 713.580.8833  
 2017.04.17  
 09-33-00-05'00"  
 E&C Engineers & Consultants Inc.  
 Texas Firm Registration No. F-003068

**E&C**  
 Engineers & Consultants Inc.  
 TX Firm Registration No: F-003068  
 1010 Lamar, Suite 650  
 Houston, Texas 77002  
 Tel 713/580-8800  
 Fax 713/580-8888  
 www.eceng.com

**UTHSC-H**  
**MSB PENTHOUSE EQUIPMENT REPLACEMENT**  
 E&C PROJECT # 3315

SKETCH: E106  
 DRAWING: ELECTRICAL NORTH PENTHOUSE  
 REVISION: 100%  
 SCALE: 1/8"=1'-0"  
 DATE: 04-17-2017



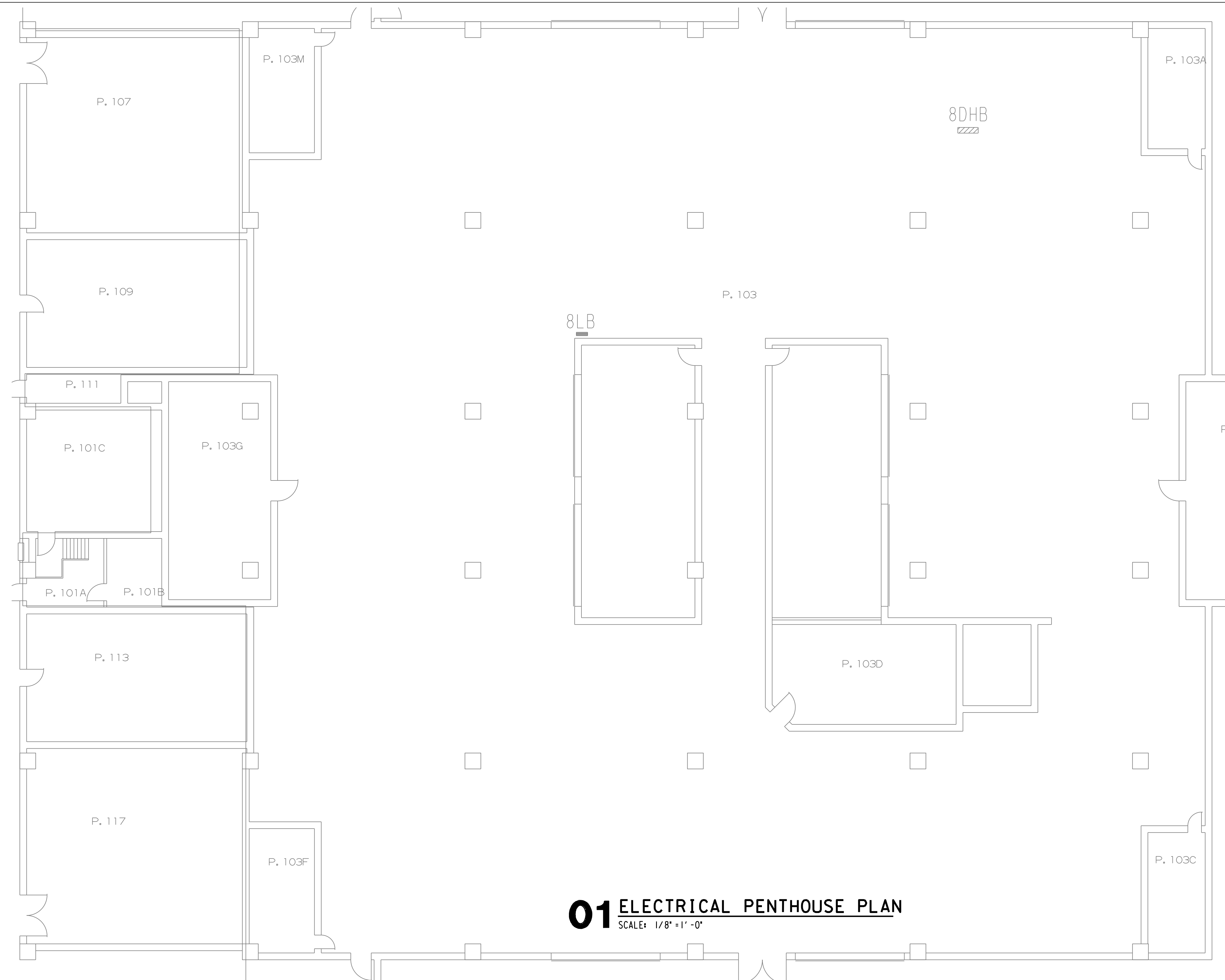

EXISTING PANELS ARE SHOWN FOR CLARIFICATION AND INFORMATION PURPOSES. REFER TO INDIVIDUAL KEY PLANS FOR APPROXIMATE SCOPE OF WORK. ALL LOCATIONS ARE APPROXIMATE.

**01 ELECTRICAL PENTHOUSE PLAN**  
SCALE: 1/8" = 1'-0"

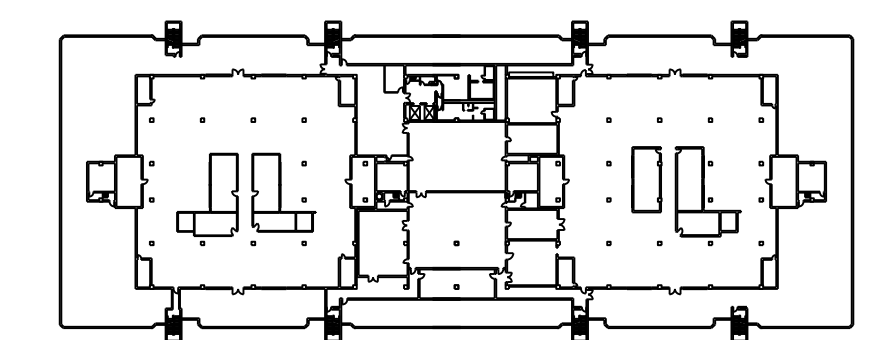

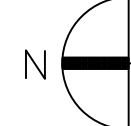
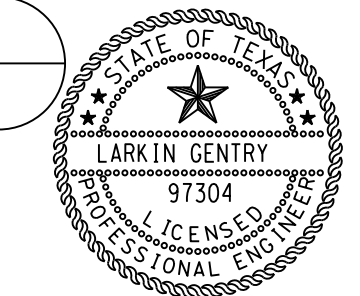

  
 Larkin Gentry  
 Houston, TX  
 713.580.8833  
 2017.04.17  
 09-33-00-05'00"  
 E&C Engineers & Consultants Inc.  
 Texas Firm Registration No. F-003068

**E&C**  
 Engineers & Consultants Inc.  
 TX Firm Registration No: F-003068  
 1010 Lamar, Suite 650  
 Houston, Texas 77002  
 Tel 713/580-8800  
 Fax 713/580-8888  
 www.eceng.com

**UTHSC-H  
 MSB PENTHOUSE EQUIPMENT REPLACEMENT**

E&C PROJECT # 3315

SKETCH: E107  
 DRAWING: ELECTRICAL SOUTH PENTHOUSE  
 REVISION: 100%  
 SCALE: 1/8"=1'-0"  
 DATE: 04-17-2017

TABLE OF CONTENTS

Section No.    Title

**DIVISION 22 – PLUMBING**

22 00 00	Plumbing Piping Systems
22 10 30	Domestic Water Heater (Steam)
22 31 00	Domestic Water Softeners
22 63 14	Lab Compressed Air System

**DIVISION 23 – MECHANICAL**

23 00 00	Basic Mechanical Requirements
23 05 29	Sleeves, Flashings, Supports and Anchors
23 07 16	Equipment Insulation
23 07 19	Piping Insulation
23 22 00	Steam and Steam Condensate Piping
23 22 00.A	Steam and Steam Condensate Specialties

**DIVISION 26 – ELECTRICAL**

26 00 00	Electrical
----------	------------

**END OF TABLE OF CONTENTS**

E&C Engineers & Consultants, Inc.  
TX Firm Registration No: F-003068  
Date: 04-17-2017  
Engineer of Record: Geoffrey Lussier  
State: Texas  
License no: 100281

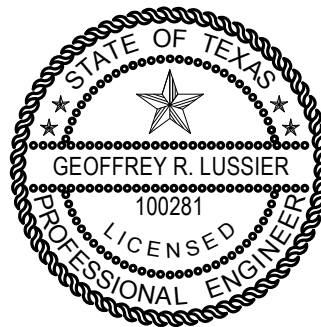

THE SEAL APPEARING ON THIS DRAWING WAS AUTHORIZED BY:

*Geoffrey R. Lussier*  
Geoffrey Lussier,  
PE  
2017.04.17  
08:19:42-05'00'

E&C Engineers & Consultants Inc.  
Texas Firm Registration No: F-003068

E&C Engineers & Consultants, Inc.  
TX Firm Registration No: F-003068  
Date: 04-17-2017  
Engineer of Record: Larkin Gentry  
State: Texas  
License no: 97304



THE SEAL APPEARING ON THIS DRAWING WAS AUTHORIZED BY:

*Larkin Gentry*  
Larkin Gentry  
Houston, TX  
713.580.8833  
2017.04.17  
09:26:33-05'00'

E&C Engineers & Consultants Inc.  
Texas Firm Registration No: F-003068



SECTION 22 00 00

PLUMBING PIPING SYSTEMS

PART 1 - GENERAL

1.1 RELATED DOCUMENTS:

- A. The Conditions of the Contract and applicable requirements of Division 1, "General Requirements", and Section 23 00 00, "Basic Mechanical Requirements", govern this Section.

1.2 DESCRIPTION OF WORK:

- A. Work Included: Provide complete operating plumbing piping systems including pipe, tube, fittings, and appurtenances as indicated and in compliance with these specifications. The work of this section may include, but not be limited to:

1. Securing and installing plumbing services for the building.
2. A complete domestic hot and cold water distribution system.
3. A complete sanitary soil waste and vent system.
4. A complete storm water piping system.
5. A complete acid waste and vent system.
6. A complete lab air piping system.
7. A complete lab vacuum piping system.
8. Miscellaneous plumbing piping, equipment and specialties required for a complete plumbing system upgrades as specified and included on the contract drawings.

- B. Plumbing Services: Secure all plumbing services necessary for the project as required or shown on the contract drawings, including paying all required fees and charges. Work related to plumbing services may be shown on Plumbing, Civil, Architectural or other drawings in the Contract Documents. Plumbing services include, but are not limited to:

1. Installing all drainage systems with the proper slope as required by code.

- C. Applications: Applications of piping systems include, but are not limited to, the systems as listed below:

<u>SYSTEM</u>	<u>WORKING PRESSURE</u>	<u>OPERATING TEMPERATURES</u>
Domestic Cold Water		
Low	150 psig	55°F to 80°F
Domestic Hot Water		
Low	150 psig	90°F to 120°F
Make-Up Water		
Low	150 psig	55°F to 80°F
Lab Air	100 psig	--
Lab Vacuum	-19" hg	--
Condensate Drainage	--	40°F to 60°F
Sanitary Drainage	--	--
Storm Drainage	--	--
Pressures	Low	Floors 1 through 6.

- D. Basic Materials and Methods: Refer to Section 23 00 00 for additional plumbing piping system requirements.
- E. Valves and Accessories: Refer to this section for additional plumbing piping system components.
- F. Vibration Isolation: Refer to Section 23 05 48, "Vibration Isolation", for piping system isolation.
- G. Insulation: Refer to Section 23 07 00, "System Insulation", for piping system insulation.

#### 1.3 QUALITY ASSURANCE:

- A. Welding: Qualify welding procedures, welders, and operators in accordance with ANSI B31.1, Paragraph 127.5, for shop and job site welding of piping work. Make welded joints on the piping system with continuous welds, without backing rings and with pipe ends beveled before welding. Gas cuts shall be true and free from burned metal. Before welding, surfaces shall be thoroughly cleaned. The piping shall be carefully aligned and no weld metal shall project inside the pipe. Refer to Section 23 00 00 for additional requirements.
- B. UPC Listing: All materials, fixtures or devices used or entering into the construction of the plumbing system shall be listed for UPC or shall conform to Alternate Standards recognized as "equal" by the City Officials having jurisdiction.
- C. All materials, distribution and utilization equipment is to be UL listed.
- D. All equipment and material is to be new, unused and manufactured in the United States.
- E. A record shall be kept of all permits and inspections submitted to the Master Plumber. A record and/or list of all equipment and devices with their locations (approved room number) will be provided to the owner upon completion.
- F. Cast Iron Pipe Manufacturers: Cast iron pipe shall be as manufactured by Tyler Pipe or Charlotte Pipe and shall bear the CI mark indicating compliance with the CISPI quality assurance and inspection program.
- G. Grooved Systems: To assure uniformity and compatibility of piping components in grooved piping systems, all grooved products utilized shall be supplied by Victaulic. Grooving tools shall be of the same manufacturer as the grooved components.

#### 1.4 SUBMITTALS:

- A. Shop drawing submittals shall include, but not be limited to, the following:
  - 1. Cut sheets marked to clearly indicate all plumbing piping system materials.
  - 2. Piping fabrication drawings for all main piping runs including connections to existing piping. Fabrication drawings shall include plan views and suitable elevations and shall include all accessories and equipment.
  - 3. Additional items as required in Section 23 00 00.
  - 4. Grooved joint couplings and fittings shall be shown on drawings and product materials, and be specifically identified with the applicable Victaulic style or series number.

#### 1.5 PRODUCT DELIVERY, STORAGE AND HANDLING:

- A. Deliver components in factory-fabricated water resistant packaging, as applicable.
- B. Handle components carefully to avoid damages to components, enclosures, and finish.
- C. Store components in a clean, dry space, and protect from weather.



## PART 2 - PRODUCTS

### 2.1 PIPING MATERIALS:

- A. General: Provide pipe and tube of type, joint, grade, size, and weight (wall thickness, schedule or class) indicated for each service. Comply with applicable governing regulations and industry standards.
1. Steel Pipe: ASTM A53 or ASTM A106 black or hot-dipped galvanized as specified. Piping shall be domestically manufactured by one of the manufacturers listed in the latest edition of the American Petroleum Institute (API) approved manufacturers listing.
  2. Copper Tube: ASTM B88, Types "K", Type "L", or Type "M" copper water tube as defined by the Copper and Brass Research Association.
  3. Ductile Iron Pipe: ANSI A21.51, Class 350 with bell and spigot ends for push-on joints.
  4. Cast Iron Soil Pipe: ASTM A74, most current edition.
  5. Hubless Cast Iron Soil Pipe: CISPI 301, most current edition.
  6. Polyvinyl Chloride (PVC) Drainage Pipe: Underground drainage piping is acceptable to be installed as schedule 40, ASTM D1785, ASTM D 2665 and ASTM F 480 with bell ends and pre-inserted gasket joints.
  7. Chlorinated Polyvinyl Chloride (CPVC) Drainage Pipe: Schedule 40 pipe and fittings per ASTM D 638.

### 2.2 PIPE/TUBE FITTINGS:

- A. General: Provide factory-fabricated fittings of type, materials, grade, class, and pressure rating indicated for each service and pipe size. Provide sizes and types matching pipe, tube, valve, and equipment connections. Where not otherwise indicated, comply with governing regulations, industry standards, and where applicable, with pipe manufacturer's instructions for selections.
1. Cast Iron Flanged Fittings: ANSI B16.1, Class 125 or Class 250, black or galvanized as specified, including bolting and gasketing.
  2. Cast Iron Threaded Fittings: ANSI B16.4 or ASTM A126, Class 125 or Class 250, black or galvanized as specified.
  3. Malleable Iron Threaded Fittings: ANSI B16.3, Class 150 or Class 300, black or galvanized as specified.
  4. Malleable Iron Threaded Unions: ANSI B16.39, select for proper piping fabrication and service requirements including style, end connections, and metal-to-metal seats (iron, bronze, or brass), plain or galvanized as specified.
  5. Threaded Pipe Plugs: ANSI B16.14.
  6. Steel Flanges/Fittings: ANSI B16.5, including bolting, gasketing, and butt weld end connections.
  7. Forged Steel Socket-welding and Threaded Fittings: ANSI B16.11, rated to match schedule of connected pipe.
  8. Wrought Steel Butt-welding Fittings: ANSI B16.9, except ANSI B16.28 for short radius elbows and returns; rated to match connected pipe.
  9. Cast Iron Drainage Fittings: ANSI B16.22 galvanized, recessed fittings with pitched threaded ends.

10. Pipe Nipples: Fabricated from same pipe as used for connected pipe, except do not use less than Schedule 80 pipe where length remaining unthreaded is less than 1/2". Do not thread nipples full length (no all-thread nipples).
  11. Wrought Copper/Bronze Solder-joint Fittings: ANSI B16.22 suitable for working pressure up to 250 psig.
  12. Hubless Cast Iron Pipe Fittings: CISPI 301, most current edition, and comply with governing regulations.
  13. Cast Iron Soil Pipe Fittings: ASTM A74, most current edition.
  14. Compression Gaskets: ASTM C1563 for gasket testing and ASTM C564 for elastomeric compound.
  15. Standard Grooved End Fittings: ASTM A234 forged steel or ASTM A53 fabricated carbon steel, or ASTM A536 ductile iron fittings joined with Victaulic Style 77 or Style 07 couplings and Grade "E" gaskets on steel systems. On copper systems, ASTM B-75 alloy C12200 or sand casting B-584-87 alloy CDA 844 (81-3-7-9) with Style 606 coupling.
  16. Flanged Fittings: Comply with ANSI B16.15 for bolt-hole dimensioning, materials, and flange-thickness.
  17. Flange Bolts: Bolts shall be carbon steel ASTM A307 Grade A hexagon head bolts and hexagonal nuts. Where one or both flanges are cast iron, furnish Grade B bolts. Cap screws utilized with flanged butterfly valves shall be ASTM A307 Grade B with hexagon heads.
  18. Flange Bolt Thread Lubricant: Lubricant shall be an antiseize compound designed for temperatures up to 1000°F and shall be Crane Anti-Seize Thread Compound or approved equal.
  19. Mechanical Joints for Cast Iron and Ductile Iron Pipe: AWWA/ANSI 21.11 with appropriate gaskets, nuts and bolts.
  20. Polyvinyl Chloride (PVC) Fittings: ASTM D2665, Carlon, Vylon "Z" high strength sewer fittings.
- B. Miscellaneous Piping Materials/Products:
1. Welding Materials: Comply with ASME Boiler and Pressure Vessels Code, Section II, Part C, for welding materials.
  2. Brazing Materials: American Welding Society, AWS A5.B, Classification BCup-5.
  3. Gaskets for Flanged Joints: 1/16" thick for all pipe size 10" and smaller and 1/8" thick for all pipe size 12" and larger. Ring-type shall be used between raised face flanges and full face-type between flat face flanges with punched bolt holes and pipe opening. Gaskets shall be Garlock Style 3400 compressed nonasbestos or equal.
  4. Insulating (Dielectric) Unions: Provide dielectric unions at all pipe connections between ferrous and nonferrous piping. Unions shall be "Clearflow" waterway as made by Victaulic, or isolating gaskets with bolt and washer kits as made by Pipeline Seal and Insulator Company or Equal as made by Watts Manufacturing Co., Inc. and shall have nylon insulation.
  5. Gaskets for Cast Iron Soil Pipe: ASTM C564, neoprene, compression-type.
  6. Push-on-joints: ANSI A21.11, rubber compression-type, "Tyton Joint" as manufactured by U.S. Pipe or equal. (for use with ductile iron pipe)
  7. Hubless Cast Iron Joints: Heavy duty couplings: Clamp all 125, Husky SD4000.



8. Solder: All solder used for sweating of water piping joints shall be 95/5 tin-antimony or tin-silver. All solder used for sweating of natural gas piping joints shall be phosphorous-free, non-lead bearing silver brazing solder with a melting point in excess of 1000°F.
9. Threadsealing Tape: Threadsealing tape used for plumbing piping applications shall be stretched or nonstretched teflon tape.

### 2.3 DOMESTIC WATER VALVES: (INCLUDING COLD AND HOT WATER)

- A. Similar types of valves shall be the product of one manufacturer; i.e., all butterfly valves shall be of the same manufacturer, all ball valves shall be of the same manufacturer, etc.
- B. Line Shut-Off Valves up to and including 2.5" shall be two-piece bronze body of ASTM B584 Alloy 844, ASTM B61, or ASTM B62, full port ball type rated at 600 WOG with threaded connections, blow-out proof stem, plastic coated lockable lever handle, Teflon packing, 316 stainless steel ball and stem. Acceptable valves are NIBCO Model T-585-70-66-LL-LF, or approved equivalent model by Crane, Milwaukee or Apollo.
- C. Line Shut-Off Valves 2-1/2" and larger where system operating pressure will not exceed 160 p.s.i.g. shall be 200 WOG threaded lug type
- D. Line Shut-Off Valves 2-1/2" and larger installed within systems having design operating pressures between 160 and 250 p.s.i.g. shall be threaded lug type
- E. Line Shut-Off Valves 2-1/2" and larger installed in roll grooved copper systems may be 300 psi roll grooved end type bronze body
- F. Provide stem extensions of a non-thermal conducting material for valves in insulated lines to allow unobstructed operation.
- G. Provide memory stops on all ball valves installed in domestic hot water return lines. Memory stops shall be adjustable after pipe insulation is applied.
- H. Provide line shut-off valves that have the same inside diameter of the upstream pipe in which they are installed.
- I. Domestic Hot Water Return Circuit Balancing Valves 1/2" through 3" shall be machined ball type calibrated balancing valve with lead free ASTM B283-C69300 Brass body/304 Stainless Steel ball construction, glass and carbon filled TFE seat rings, EPDM stem "O" ring, threaded NPT inlet/outlet connections, 400 psig maximum working pressure at 250°F. Valve shall have differential pressure read-out ports across valve seat area fitted with internal EPT inserts/check valves. Valve body shall have 1/4" NPT tapped drain/purge port. Valve shall have calibrated nameplate and memory stop feature to allow valve to be closed for service and then reopened to set point without disturbing balance position. Valve shall contain less than 0.25% lead content by weight on wetted surfaces and be designed for positive shut-off.. Valves shall be same size as the pipe installed. Provide valves as scheduled on Contract Drawings manufactured by Bell & Gossett Circuit Setter Plus CB series, or Owner approved equal.
- J. Swing Check Valves, 2" and smaller - "Y" or "T" pattern bronze, Class 150, with threaded connections and screw-in cap. Manufactured by NIBCO Model T-433-Y or approved equivalent model by Milwaukee or Crane.
- K. Spring Loaded Check Valves, 2" and smaller - Silent closing, bronze, Class 125, with threaded connections, Buna disc, bronze or stainless steel spring. Manufactured by NIBCO Model T-480 or approved equivalent model by Milwaukee or Crane.

- L. Swing Check Valves, 2-1/2" and larger - 200 pound CWP, Iron body, with bronze or stainless steel trim. Manufactured by NIBCO Model F-918-B or approved equivalent model by Milwaukee or Crane.
- M. Swing Check Valves, 2-1/2" and larger - 285 pound CWP, Iron body, with stainless steel trim. Manufactured by NIBCO Model F-938-33 or approved equivalent model by Milwaukee or Crane.
- N. Spring Loaded Check Valves, 2-1/2" and larger - 200 pound CWP, Iron body, with bronze or stainless steel trim. Manufactured by NIBCO Model F-910 or approved equivalent model by Milwaukee or Crane.
- O. Spring Loaded Check Valves, 2-1/2" and larger - 400 pound CWP, Iron body, with bronze or stainless steel trim. Manufactured by NIBCO Model F-960 or approved equivalent model by Milwaukee or Crane.

### PART 3 - EXECUTION

#### 3.1 PIPING INSTALLATION:

##### A. General:

1. Industry Practices: Install pipe, tube, and fittings in accordance with recognized industry practices which will achieve permanently leak proof piping systems, capable of performing each indicated service without failure or degradation of service. Install each run with a minimum of joints and couplings, but with adequate and accessible unions or flanged connections to permit disassembly for maintenance/replacement of valves and equipment. Reduce sizes (where indicated) by use of reducing fittings. Align accurately at connections, within 1/16" misalignment tolerance. Coordinate piping locations with other trades to avoid conflict. Give ductwork preference unless directed otherwise by the Engineer.
2. Systems: Install piping parallel or perpendicular to lines of building, true to line and grade, and with sufficient hangers to prevent sags between hangers. Provide fittings at changes in direction. Piping in finished areas shall be concealed, except in mechanical rooms. Where pipes of different sizes join, provide reducing elbows, tees, or couplings. Bushings will not be acceptable.
3. Expansion and Contraction: Install loops, offsets, sizing joints, and expansion joints, as necessary, to avoid strain resulting from expansion and contraction of piping systems on fixtures and equipment.
  - a. Expansion Loops and Offsets: Provide expansion loops and offsets in piping systems for not less than one inch (1") expansion or contraction per 100' of pipe. Use Victaulic style 75 or 77 flexible type couplings on expansion loops in accordance with the latest Victaulic recommendations for expansion compensation.
  - b. Mechanical Grooved Couplings: Provide mechanical grooved connections equal to Victaulic style 75 or 77 where indicated on the Drawings and Specifications to reduce vibration at equipment connections. Provide expansion joints in piping systems by mechanical grooved connections where specifically indicated on the Drawings. Expansion joints shall be of one of the following types:
    1. Packless, gasketed slip-type expansion joint grooved end telescoping body for installation with Victaulic style 07 rigid type couplings, providing axial end movement up to 3". Victaulic style 150 Mover.
    2. combination of Victaulic style 77 or 75 flexible type couplings and short nipples joined in tandem for increased expansion. Joined movement and expansion capabilities determined by the number and style of couplings/nipples used in the joint. Victaulic series 155.

4. Pipe Grading: Install domestic water piping to pitch down in the direction of flow for drainage. Grade storm, soil, and waste piping at 1/4" per foot whenever possible, and not in any case less than 1/8" per foot for pipe sizes 4" and larger, unless shown otherwise on the Drawings. Grade vent piping at 1/4" per foot whenever possible, and not in any case less than 1/8" per foot toward vents. Grade gas piping at a minimum of 1/8" per foot toward condensation traps at connected equipment.
  - B. Steel Pipe: Ream steel pipe after cutting and before threading. Thread with clean-cut taper threads of length to engage all threads in fittings and leave no full-cut threads exposed after make-up. Use John Crane or approved equal teflon thread tape applied only to male threads to make-up joints.
  - C. Copper Pipe: Cut copper pipe square and ream to remove burrs. Clean fitting socket and pipe ends with sand cloth, No. 00 cleaning pads or wire brush. No acids shall be used to clean either pipe or fittings or as a flux in sweating joints. The use of drilled T connections is not permitted.
  - D. PVC Pipe: Cut PVC pipe square and remove all burrs. Clean fitting and pipe butt prior to installation. Install all PVC piping in accordance with the manufacturer's recommendations. Underground installation of PVC piping shall be in compliance with ASTM D2321.
  - E. Final Connections to Equipment Furnished by Owner or Under Other Divisions of These Specifications: Where Drawings show equipment to be furnished under other Divisions of these Specifications or by the Owner, such equipment will be delivered to the site, uncrated, assembled, and set in-place under those other Divisions of these Specifications or under the separate contracts. Any required automatic control valves shall also be provided under those other Divisions of these Specifications or other separate contracts. Make all final connections of chilled water, hot water, condenser water, gas, domestic water, waste, and vent as shown. Provide valves, unions, strainers, check valves, and traps as required for proper operation of systems and equipment. Equipment not shown or noted on the piping drawings shall not be included in the scope of this requirement.
  - F. Pipe Fabrication Drawings:
    1. Pipe fabrication drawings shall be submitted for all piping in the Mechanical Rooms, Penthouse and for Equipment connections and all other areas requiring coordination with other trades.
    2. Pipe fabrication drawings shall be double line drawings to scale on 1/4" scale building floor plans and shall indicate pipe size, fittings, valves, accessories, connections, system type, insulation, support requirements, pipe elevations and other information required for coordination with other trades and fabrication of pipings.
    3. Pipe fabrication drawings shall be coordinated with other trades and building construction prior to submittal for approval. Refer to Section 23 01 00 for additional shop drawing requirements.
  - G. Basic Materials and Methods: Refer to Section 23 03 00 for additional requirements related to plumbing piping.
- 3.2 PLUMBING SERVICES:
- A. General: Install the various piping systems as described and as required by the local plumbing inspection department.
    1. Slope domestic hot and cold water piping to drain and provide with hose valves (drain valves) at low points. Branch taps shall be made from the top of the piping main.
    2. Install soil, waste, and vent piping with horizontal lines pitched in accordance with local codes, but in no case less than 1/4" per foot for pipe 3" and smaller and 1/8" per foot for pipe 4" and larger. Install soil, waste, and vent piping with hubs of each length of piping in the upstream position.



3. Make-up "Ty-Seal" or "Charlotte Seal" or "Quick-tite" (extra heavy) gasketed joints using lubrication and joining tools as instructed by the manufacturers. Base of stacks, horizontal runs under pressure, and gasketed pipe 5" and larger shall be made up using "Tyler Lubrifast" joining material. Horizontal joints, 5" and larger, shall be restrained.
4. Torque "No-Hub" joints in accordance with manufacturer's instructions. Do not install "No-Hub" joints below ground.
5. Provide chrome-plated piping at each fixture installed in a finished space. Install with proper strap wrenches to avoid marking or defacing.
6. Provide proper restraints on riser and stack offsets.

### 3.3 MAKE-UP WATER PIPING SYSTEMS:

- A. General: Provide necessary pipe and fittings. Make final connections to provide cold water make-up and natural gas supply to mechanical equipment. Locate cold water make-up and gas supply where shown and connect with suitable stop valves, check valves and bypass valves as applicable.
- B. Connections: Connect domestic water to automatic fill and manual quick-fill connections on each HVAC piping system and as shown on Drawings. Provide reduced pressure backflow preventers at each system.
- C. Compatibility: Use piping and fittings of same material type as materials of the domestic water supply.

### 3.4 DOMESTIC HOT AND COLD WATER PIPING SYSTEMS:

- A. Interior Hot and Cold Water Piping:
  1. Piping 3" and smaller, Type "L" copper tubing hard drawn joined using non-lead bearing solder, such as 95-5 silver or antimony solder (95% tin and 5% silver or antimony).
  2. Piping 4" and larger, Schedule 40, galvanized steel pipe, ASTM A53 with galvanized malleable iron fittings, or galvanized cast iron flanged fittings.
  3. Provide isolation fitting whenever dissimilar materials are used.
  4. Option: At the Contractor's option with the owner's approval, for galvanized steel piping 4" and larger, a grooved piping connection system with "cut-grooves" may be used. Grooved couplings shall be Victaulic Style 75 or 77 flexible type with Grade "E" synthetic rubber gaskets. Rigid couplings shall be used at valves and in other areas where piping system rigidity is required and shall be Victaulic Style 07 Zero-Flex couplings with Grade "E" gaskets synthetic rubber gaskets. Taps to mains shall be made using Victaulic Style 72 or Style 920/920N hot dip galvanized outlet couplings or fittings or Gruvlok Fig. 7045/7046 hot dip galvanized outlet couplings or fittings. Mechanical "T" couplings with U-bolts shall not be permitted. Flange connections shall be made using Victaulic Style 741 or 743 flanges with Grade "E" synthetic rubber gaskets. Fittings for elbows, tees, reducers, etc. shall be Victaulic or Gruvlok hot dip galvanized full flow fittings. All grooved piping connection materials shall be utilized with the manufacturer's recommended groove cutting tool. All grooved piping couplings and fittings used in association with an individual coupling or fitting shall be by the same manufacturer. The use of boltless couplings, reducing couplings and Mechanical "T" fittings with U-bolts is prohibited. All wetted surfaces in the piping system shall be hot dip galvanized and all proposed grooved piping connection materials shall be suitable for domestic water use at the temperatures and pressures at the point of application. Painted couplings may be used where they meet the above requirements. Grooved reducing couplings shall not be installed.

- B. Piping Runouts to Fixtures: Provide piping run outs to fixtures sized to comply with governing regulations. Where not otherwise indicated, provide run outs sized to comply with the following: lavatories - 1/2" hot, 1/2" cold; water closet flush valves - one and one half inch (1-1/2") cold; urinal flush valves - three-quarter inch (3/4") cold; drinking fountains - 1/2" cold. Provide each fixture with a shut-off valve for each supply line. All exposed lines shall be chromium-plated.
- C. Air Chambers:
1. Riser Shock Arrestors: At the top of each main hot and cold water riser, provide a properly sized Wade Shoktrol or approved equal sealed air chamber.
  2. Fixture Shock Arrestors: At each hot and cold water supply pipe at each fixture, provide a properly sized Wade Shoktrol or approved equal.
- 3.5 STORM AND SANITARY DRAINAGE SYSTEM:
- A. Vertical Waste and Vent Stacks Above Grade: All above grade waste and vent piping is to be service weight no hub cast iron pipe and fittings with coupling type connectors. Elastomeric gaskets shall be installed using gasket lubricant. All horizontal stack offsets and elbows (4" and larger) shall be joint-strapped and supported with the properly sized restraint assembly as manufactured by the Holdrite Company.
- B. Horizontal Fixture, Waste and Vent Piping Above Grade: Connect to the vertical stack with "No-Hub" cast iron soil pipe and fittings assembled with Stainless Steel No-Hub Coupling Assemblies.
- C. Building Storm Piping Above Grade: All above grade storm drainage piping is to be service weight no hub cast iron pipe and fittings with coupling type connectors. Elastomeric gaskets shall be installed using an approved gasket lubricant. All horizontal stack offsets and all elbows shall be joint-strapped and supported with the properly sized restraint assembly as manufactured by the Holdrite Company.
- D. Insulation: All condensate drains and related piping, roof drain and overflow roof drain bodies and horizontal runs of storm drainage piping within the occupied spaces of the building, shall be insulated as specified in Section 23 07 00.
- E. Cleanouts:
1. Locations:
    - a. At base of every drainage stack.
    - b. Upper terminal of each horizontal drainage pipe.
    - c. Each 90' length of horizontal straight run of drainage piping on the exterior, each 50' length of horizontal straight run of drainage piping in the interior.
    - d. Where shown on Drawings.
    - e. As required by local code.
  2. Size: Cleanouts shall be line size for piping up to 4" and 4" size for piping larger than 4".
  3. Access: Provide access doors for access to cleanouts installed in concealed locations.
- F. Fixture Connections:
1. Water Closets: Galvanized castable nipples.
  2. Urinals: Copper or cast iron nipples with suitable adapters.
  3. Lavatories: Copper or cast iron nipples with suitable adapters.
  4. Service Sinks: Brass or cast iron nipples with suitable adapters.
  5. Drinking Fountains: Copper or cast iron nipples with suitable adapters.

3.6 CONDENSATE DRAINAGE:

- A. General: Provide a condensate drain pipe to connect each cooling unit drain pan and secondary drain pan to extend to and discharge into an open-type drain in the plumbing system.
- B. Assembly: Use Schedule 40, galvanized steel pipe made up with Class 125, galvanized, threaded fittings. Assemble fittings to form a trap with depth equal to or greater than operating pressure of the unit served. Drains shall be of the sizes indicated, but not less than the full size of the drain pan connection. Air handling unit drains shall have deep seal traps to permit unit pan drainage. Install a deep seal trap for each blow-through or draw-through air handling unit to maintain the water seal.

3.7 CHASE AND WALL PIPING SUPPORTS:

- A. All piping whether sanitary or water shall be rigidly installed in all chases or walls. Test for rigidity shall be that the piping is virtually immovable by hand short of deforming the piping. Valve, stop and fixture penetrations thru chase or fixture mounting walls shall be firmly supported from just inside the wall or chase prior to penetration to the room-side of the chase or wall.
- B. Support inside the chase or wall for Sanitary Waste and Vent Piping shall be accomplished by utilizing fixture carrier bolt-downs, "Uni-Strut" or similar structural bracing system, "U-bolts", nuts and lock-washers, all bolted to the floor and to the piping system.
- C. Support for Water Piping or other similar service piping shall be accomplished by using a "system" designed for that purpose. An approved system shall consist of preformed steel supports which shall be installed between studs or joists and preformed nonmetallic pipe holder inserts which are designed to rigidly support or hold the piping to the steel supports.
- D. In no case shall Sanitary Sewer Waste or Vent Piping depend on blocks, brick, stone or wood sleepers for its final support. In no case shall Water Piping or similar service piping depend on its final support on "tie-wires", soldering or brazing to metal studs or joists, copper tube soldered to risers and tied to joists or any other method which does not have the written approval of the Engineer. Piping improperly supported shall have improper supports promptly removed and replaced with specified supports at the direction of the Engineer at no additional cost to the Owner and/or Architect/Engineer.
- E. Support system shall be as manufactured by "Holdrite" or an approved equal.

3.8 CLEANING, FLUSHING, TESTING AND INSPECTING:

- A. Cleaning: Clean exterior surfaces of installed piping systems and prepare surface for application of any required coatings.
- B. Piping Tests:
  - 1. General: Blank off equipment during tests. Perform tests before piping is enclosed in walls, floors, partitions or in any other way concealed from view. Tests may be performed in sections. Tests shall be witnessed by the Engineer or Owner's Representative and local inspectors and results presented to the Engineer for acceptance and approval prior to concealing piping from view. Provide all necessary equipment for testing, including pumps and gauges. Refer to Section 23 01 00 for additional requirements
  - 2. Test Results: After all tests are completed a written test report. The report is to include the date and time of the test, whether or not the system passed and a summary of the remedial work required to fix the system, then the date and time of the re-test.
  - 3. Domestic Water Systems: Test hot and cold water systems hydrostatically to a pressure of 150 psig or 1-1/2 times working pressure, whichever is greater, for a period of 24 hours. Repair all leaks, replacing materials as necessary, and repeat tests until systems are proven tight.



4. Soil, Waste and Vent Piping System: Test soil, waste, and vent piping by plugging all openings and filling system to height required by the owner's representative, but not less than 10' above the level of the pipe being tested, for a minimum of 3 hours. Inspect all joints for leaks, repair all leaks found, and retest until piping is demonstrated to be free from leaks as evidenced by no perceptible lowering of the water level after 3 hours. In addition to water test, apply peppermint or smoke tests, if required by local code.
  5. Storm Drainage Piping System: Test storm drainage piping same as specified for Soil, Waste, and Vent Piping System. Refer to the contract drawings for more information.
  6. Sump Pump and Sewage Ejector Discharge Piping: Test sump pump and sewage ejector piping same as specified for domestic water systems.
  7. Flushing: Flush water piping systems with clean water following successful testing.
  8. Fire Protection Piping: Test the fire protection piping system hydrostatically to a pressure of 200 psig for a period of 2 hours. Repair all leaks, replacing materials as necessary, and repeat tests until systems are proven tight.
  9. All drain lines; storm drain, sanitary sewer, condensate, etc... shall be flow tested prior to the contractor obtaining notice of substantial completion.
- C. Disinfection of Water Systems: Disinfect hot and cold water systems as follows: Fill systems with water solution containing 50 ppm available chlorine; allow to stand for 8 hours, opening and closing all valves several times during this period; thoroughly flush; refill and place system in service; ensure a residual chlorine content of 0.2 ppm. Refer to Section 23 03 00 for additional requirements.
- D. Cleaning and Adjusting: Thoroughly clean and disinfect all plumbing fixtures, including all exposed trim. Adjust all flush valves for proper flushing, but without excess use of water. Demonstrate to the Engineer that the entire plumbing system and all its components are functioning properly.
- E. Inspecting: Visually inspect each run of each system for completion of joints, adequate hangers, supports, and inclusion of accessories and appurtenances.
- F. Grooved Piping Installation: Grooved joint piping systems shall be installed in accordance with the manufacturer's (Victaulic) guidelines and recommendations. All grooved couplings, fittings, valves and specialties shall be supplied by a single manufacturer. Grooving tools shall be supplied by the same manufacturer as the grooved components. The gasket style and elastomeric material (grade) shall be verified as suitable for the intended service as specified. Gaskets shall be supplied by Victaulic. Grooved end shall be clean and free from indentations, projections and roll marks in the area from pipe end to groove. A Victaulic factory trained field representative shall provide on-site training to contractor's field personnel in the installation of grooved piping products. Factory trained representative shall periodically review the product installation. Contractor shall remove and replace any improperly installed products.
- 3.9 IDENTIFICATION:
- A. Refer to Section 23 03 00 for applicable painting, nameplates, and labeling requirements.

END OF SECTION 22 00 00

SECTION 22 10 30 – SEMI-INSTANTANEOUS DOMESTIC WATER HEATERS (STEAM)

PART 1 - GENERAL

1.01 RELATED DOCUMENTS

- A. Drawings and general provisions of the Contract, including General Conditions and Division 01 Specification Sections, apply to this Section.
- B. Specifications throughout all Divisions of the Project Manual are directly applicable to this Section, and this Section is directly applicable to them.

1.02 SUMMARY

- A. This section covers providing all labor and materials for the complete first class installation of domestic semi-instantaneous steam hot water generating systems indicated and scheduled on Contract Drawings complete with all equipment, controls, piping, valves, accessories, testing, start-up and other normal parts that make the systems complete, operable and acceptable to the authorities having jurisdiction.

1.03 REFERENCE STANDARDS

- A. The latest published edition of a reference shall be applicable to this Project unless identified by a specific edition date.
- B. All reference amendments adopted prior to the effective date of this Contract shall be applicable to this Project.
- C. All materials, installation and workmanship shall comply with the applicable requirements and standards addressed within the following references:
  - 1. 2012 Edition of the International Plumbing Code.
  - 2. Conform to ASME Section VIII Division 1 for manufacture of pressure vessels for heat exchangers.
  - 3. Underwriters Laboratories Listings

1.04 QUALITY ASSURANCE

- A. Perform Work in accordance with State of Texas Department of Health Standards.
- B. Water heaters shall be manufactured by a company that has achieved certification to the ISO 9001 International Quality System.
- C. Provide equipment with manufacturer's name, model number, and rating/capacity permanently identified.
- D. Ensure products and installation of specified products are in conformance with recommendations and requirements of the following organizations:
  - 1. National Sanitation Foundation (NSF).
  - 2. American Society of Mechanical Engineers (ASME).

3. National Board of Boiler and Pressure Vessel Inspectors (NBBPVI).
4. National Electrical Manufacturers' Association (NEMA).
5. Underwriters Laboratories (UL).

#### 1.05 SUBMITTALS

##### A. Product Data:

1. Provide manufacturer's recommended piping arrangement diagram. Include dimension drawings of water heaters indicating piping, components and required connections, size of tapings, drains, anchors, lifting points and attachments.
2. Manufacturer's data sheets and installation instructions.
3. Provide wiring diagrams, electrical characteristics and connection requirements.

##### B. Record Documents:

1. Provide full written description of manufacturer's warranty.

##### C. Operation and Maintenance Data:

1. Include operation, maintenance, and inspection data, replacement part numbers and availability, and service depot location and telephone number.

#### 1.06 DELIVERY, STORAGE AND HANDLING

- A. Provide temporary inlet and outlet caps. Maintain caps in place until installation.
- B. Do not operate the hot water generator for any reason until the factory startup service has been completed.

#### 1.07 WARRANTY

- A. Tank Warranty: Generator tanks shall have a minimum of an eight (8) year warranty to protect the Owner against defects in material and workmanship, discolored water or tank perforation due to erosion and corrosion. Should the tank or liner fail for any reason with the first eight full years after startup, the manufacturer shall, at the Owner's option, pay for all repairs or replacement, including material, labor, incidental costs, and freight. The tank warranty must be submitted with the total package submittals. The submission of any submittal with a warranty less than that described or the absence of a warranty with the submittal, will be sufficient cause for complete submittal rejection.
- B. Heat Exchanger Warranty: The heat exchanger shall have a minimum of a three (3) year warranty against material and workmanship, corrosion and erosion, thermal shock, and fouling. All material, labor freight, and incidental expenses shall be the responsibility of the manufacturer should the warranty be exercised. The heat exchanger warranty must be submitted with the total package submittals. The submission of any warranty less than that described or the absence of a warranty with the submittal, will be sufficient cause for complete submittal rejection.



PART 2 - PRODUCTS

2.01 GENERAL

- A. All materials shall meet or exceed all applicable referenced standards, federal, state and local requirements, and conform to codes and ordinances of authorities having jurisdiction.

2.02 PACKAGED DOMESTIC HOT WATER HEATER (STEAM HEATING MEDIUM):

- A. Acceptable Manufacturers:
1. Ace Boiler Inc. "Mini-Pack"
  2. AERCO International "SWDW"
  3. Patterson-Kelley Company "Compact"
  4. PVI Industries "Quickdraw"
  5. RECO "Thermodyne HX"
- B. Furnish and install packaged semi-instantaneous double-wall domestic hot water heaters with dimensions and capacities as scheduled on the Contract Drawings and as outlined herein. This Specification describes minimum quality and performance requirements. Variations of system components by the individual referenced manufacturers are acceptable for installation in this project provided they meet or exceed all of the requirements indicated herein and fit properly in the space provided. Refer to the manufacturer's recommended installation documents for the installation of multiple heaters connected in a parallel configuration.
- C. Heaters shall be designed, manufactured and stamped in accordance with Section VIII Div. 1 of ASME Code for design pressures of 150 PSIG at 210 degrees F. shell side and 150 PSIG at 370 degrees F. or 370 PSIG at 450 degrees F. tube side. ASME label with National Board registration.
- D. Each heater shall be U-tube, removable tube bundle type. The water shall be heated in the shell and the steam condensed inside the tubes. Heaters shall have an integrally mounted non-ferrous recirculating water system to maintain the potable water within +/- 4 degrees F. of the specified outlet temperature under all normal conditions. The closure between hot water bonnet, tube sheet and shell flange must be made so either the tube side or shell side gasket can be inspected or replaced without disturbing the other gasket.
- E. The shell shall be constructed of solid austenitic type 316L stainless steel with 304L stainless steel fittings. Non-metallic shell liners will not be acceptable. The tubing shall be double-wall copper U-tubes expanded into a solid 304 stainless steel shellside tubesheet and a carbon steel tubeside tubesheet. An open and fully visible 360 degree 3/8" wide leak detection gap shall exist between the two tube sheets. Tubing shall be 3/4" O.D. outer tube and 5/8" O.D. inner tube both of seamless 90/10 copper nickel. The combined metal thickness of the double tube walls shall not be less than .07 inch thickness excluding the leak detection groove depth.

- F. In order to provide positive detection and indication of leakage across the exchanger, the common surface between the inner and outer tubes shall be provided with a continuous network of leak detection passages all connected directly to the "tell-tale" space between the inner and outer tube sheets. Design shall provide fully visible 360 degree vented leak detection between tube sheets. "Weep-hole" designs are not acceptable. Design shall allow on-Site discovery and sealing of leaking tubes without requiring removal of the tube bundle.
- G. Each heater shall be completely assembled, ready to be connected at the installation Site and include:
  - 1. Steam control valve with steam piloted temperature control, inlet strainer and down stream vacuum breaker.
  - 2. Float and thermostatic condensate trap.
  - 3. Compound steam pressure gage, 3-1/2" dial, with syphon and shut off cock.
  - 4. Combination water pressure-temperature relief valve, ASME certified.
  - 5. Water recirculation system, non-ferrous with circulator and isolation valves, 115V/60HZ/single phase.
  - 6. Nema 1 panel with on/off switch, green light (normal), red light(high temperature), manual-reset temperature limiting device with high temperature safety system to shut off hot water flow on pre-selected high temperature setting and dry contacts for remote "High Limit Tripped Status" indication.
  - 7. Shell insulation: 1-1/2" thick fiber glass type with outer 20 gauge stainless steel jacket to comply with the latest ASHRAE 90 requirements.

2.03 EXPANSION TANKS:

- A. Acceptable Manufacturers:
  - 1. Armstrong
  - 2. Amtrol
  - 3. Watts Regulator
  - 4. Elbi
- B. Expansion tanks shall be pre-charged diaphragm type designed and constructed per ASME, Section VIII, Division 1. Each tank shall be supplied with heavy duty FDA approved butyl lining, standard air charging valve, non-ferrous pipe connections and stamped for a minimum working pressure of 125 psig.
- C. Expansion tank capacity and mounting type shall be as scheduled on Contract Drawings.

PART 3 - EXECUTION

3.01 INSTALLATION

- A. Installation shall meet or exceed all applicable federal, state and local requirements, referenced standards and conform to codes and ordinances of authorities having jurisdiction.
- B. All installation shall be in accordance with manufacturer's published recommendations.
- C. Install the water heaters, piping and accessories in accordance with the manufacturer's installation instructions.
- D. Furnish all supports required by the equipment included in this Contract.
- E. Provide a 4" thick, reinforced concrete housekeeping pad beneath units.
- F. Furnish and install all necessary valves, traps, gauges, strainers, unions, etc. to facilitate proper functioning and servicing of equipment.
- G. When installed water heaters are not equipped with integral temperature gauge, provide a temperature gauge in the domestic hot water piping within five feet of outlet to each heater. Size and locate gauges to be easily readable from a standing position.
- H. Provide dielectric isolation device where copper lines connect to ferrous lines or equipment, such as dielectric coupling or dielectric flange fitting.
- I. Install a line size shutoff valve in cold water inlet and hot water outlet close to each heater.
- J. Route condensate to a vented receiver.
- K. Pipe T&P relief valve discharge and all equipment drains indirectly to appropriate floor drain.
- L. Set the operating and safety controls.
- M. Set thermostats on domestic water heaters to deliver maximum water temperature as indicated on Contract Drawings.
- N. Furnish and install an expansion tank on cold water supply to heater. Locate tank as close to water heater as possible between water heater and all check valves or backflow preventers. Install expansion tank in accordance with manufacture's recommendations.
- O. Expansion tank factory pre-charge pressure may not be correct for this installation. Tank must be charged to system design fill pressure before being filled with water. If the system has been filled, the tank must be isolated from the system and the tank emptied before charging. Verify static pressure within the existing domestic hot water system at the Site and adjust tank pressure accordingly.

3.02 STARTUP

- A. Startup on hot water generators shall be performed by factory trained and authorized personnel. A copy of the startup report shall be provided to the Owner. The factory representative shall also provide a technical and practical operation and maintenance training seminar including a hands-on operation and maintenance demonstration, and classroom presentation with handouts and visual aids, for no less than three physical plant personnel.

END OF SECTION 22 10 30

SECTION 22 31 16 – DOMESTIC WATER SOFTENERS

PART 1 - GENERAL

1.01 RELATED DOCUMENTS

- A. Drawings and general provisions of the Contract, including General Conditions and Division 01 Specification Sections, apply to this Section.
- B. Specifications throughout all Divisions of the Project Manual are directly applicable to this Section, and this Section is directly applicable to them.

1.02 SUMMARY

- A. Furnish and install a complete water softening system as scheduled on the Drawings including softener tanks, brining system, valves and any associated piping, controls and appurtenances.

1.03 REFERENCE STANDARDS

- A. The latest published edition of a reference shall be applicable to this Project unless identified by a specific edition date.
- B. All reference amendments adopted prior to the effective date of this Contract shall be applicable to this Project.
- C. All materials, installation and workmanship shall comply with the applicable requirements and standards addressed within the following references:
  - 1. 2012 Edition of the International Plumbing Code
  - 2. NOTE: MD Anderson takes various exceptions to the International Plumbing Code and has adopted the more stringent requirements within the Uniform Plumbing Code. These exceptions are included within Project Specifications and/or Project Design Drawings.
  - 3. ANSI/NSF Standard 61 - Drinking Water System Components - Health Effects
  - 4. Texas Water Code Chapter 37
  - 5. Texas Health & Safety Code Chapter 341
  - 6. Title 30 Texas Administrative Code, Chapter 30, Subchapter H
  - 7. Underwriters Laboratories Listings.
  - 8. 2014 Edition of the National Electric Code

1.04 QUALITY ASSURANCE

- A. Manufacturer's name and contact information shall be permanently marked on equipment.
- B. ASME Compliance for Steel Tanks: Fabricate and label mineral tanks to comply with ASME Boiler and Pressure Vessel Code: Section VIII.



- C. Electrical Components, Devices, and Accessories: Listed and labeled as defined in NFPA 70, Article 100, by a testing agency acceptable to authorities having jurisdiction, and marked for intended use.
- D. Manufacturer Qualifications: Company shall have minimum three years documented experience specializing in manufacturing the products specified in this section.
- E. Installer Qualifications:
  - 1. Company shall have minimum three years documented experience specializing in performing the Work of this section and be licensed by the State of Texas to install water treatment equipment.
  - 2. Installation of plumbing systems shall be performed by individuals licensed by the Texas State Board of Plumbing Examiners as a Journeyman or Master Plumber. Installation may be performed by Apprentice Plumbers provided they are registered with the Texas State Board of Plumbing examiners and under direct supervision of a licensed plumber. All installation shall be supervised by a licensed Master Plumber.
  - 3. All installers of water treatment equipment must meet the qualifications and be licensed according to the State of Texas.

#### 1.05 SUBMITTALS

- A. Product Data:
  - 1. Code and Standards compliance, manufacturer's data for pipe, fittings, valves, controls, water testing kits and all furnished specialties, and accessories.
  - 2. Include rated pressures, temperatures, capacities and operating characteristics.
  - 3. Manufacturer's installation instructions.
- B. Record Documents:
  - 1. Shop Drawings: Include plans, elevations, sections, details, and connections to piping systems. Indicate size, profiles, and dimensional service requirements of system based on the specific components being installed.
  - 2. Wiring Diagrams: Power, signal, and control wiring.
  - 3. Manufacturer Certificates: Signed by manufacturers certifying that water softeners comply with requirements.
  - 4. Maintenance service agreement.
  - 5. Provide full written description of manufacturer's warranty including special warranty specified in this Section.
  - 6. Source and Site quality-control test reports.
- C. Operation and Maintenance Data:

1. Include manufacturer's operation instructions, start-up data and trouble-shooting check lists.
2. Include system components manufacturer's literature, servicing requirements, Record Documents, installation instructions, exploded assembly views, replacement part numbers and availability.
3. Include cleaning procedures, preventive maintenance schedule, preventive maintenance recommendations and procedures.
4. Identify place of purchase, location and contact numbers of service depot and technical support for each product installed.

1.06 DELIVERY, STORAGE AND HANDLING

- A. All components and materials shall be new, undamaged, and free of rust.
- B. Accept water softeners and components on Site in factory packing. Inspect for damage. Comply with manufacturers rigging and installation instructions.
- C. Provide temporary protective coating and end plugs on valves not packaged within containers. Maintain in place until installation.
- D. Provide temporary end caps and closures on openings, connections, pipe and fittings. Maintain in place until installation.
- E. Protect piping systems from entry of foreign materials by temporary covers, completing sections of the work and isolating parts of completed system.
- F. Protect all components and materials that are to be installed within this project from exposure to rain, freezing temperatures and direct sunlight. EXCEPTION: Materials manufactured for exterior locations.

1.07 EXTRA MATERIALS

- A. Furnish extra materials that match products installed and that are packaged with protective covering for storage and identified with labels describing contents.
  1. Refer to Section 01 78 46 for Maintenance Material Requirements.

1.08 WARRANTY

- A. The manufacturer shall guarantee that under actual operating conditions the effluent shall contain no greater than two GPG hardness as determined by soap test; that the loss of ion exchange resin through attrition during the first three years of operation shall not exceed 3 percent per year; that the resin shall not be washed out of the system during the service run or backwashing period; that the turbidity and color of the effluent, by reason of passing through the softener system, shall not be greater than the incoming water. The manufacturer shall also guarantee that any mechanical equipment which proves defective in workmanship or materials within one year after installation shall be replaced without charge to the Owner.
- B. Special Warranty: Manufacturer's standard form in which manufacturer agrees to repair or replace components of water softener that fail in materials or workmanship within specified warranty period.

1. Failures include, but are not limited to, the following:
  - a. Structural failures of mineral and brine tanks.
  - b. Faulty operation of controls.
  - c. Deterioration of metals, metal finishes, and other materials beyond normal use.
  - d. Attrition loss of resin exceeding 3 percent per year.
  - e. Mineral washed out of system during service run or backwashing period.
  - f. Effluent turbidity greater and color darker than incoming water.
  - g. Fouling of underdrain system, gravel, and resin, with turbidity or by dirt, rust, or scale from softener equipment or soft water, while operating according to manufacturer's written operating instructions.
2. Warranty Period: From date of Substantial Completion.
  - a. Mineral Tanks: Ten years.
  - b. Brine Tanks: Five years.
  - c. Controls: Five years.
  - d. Underdrain Systems: Ten years.

#### 1.09 MAINTENANCE SERVICE

- A. Submit four copies of manufacturer's "Agreement for Continued Service and Maintenance," before Substantial Completion, for Owner's acceptance. Offer terms and conditions for furnishing chemicals and providing continued testing and servicing to include replacing materials and equipment. Include one-year term of agreement with option for one-year renewal.

### PART 2 - PRODUCTS

#### 2.01 GENERAL

- A. All materials shall meet or exceed all applicable referenced standards, federal, state and local requirements, and conform to codes and ordinances of authorities having jurisdiction.

#### 2.02 ACCEPTABLE MANUFACTURERS

- A. Watertech Services
- B. Bob Johnson & Associates

#### 2.03 WATER SOFTENER (WS)

- A. Furnish, install and place in operation an automatic water softening system with quantity of tanks, flow rates, cubic feet of NSF approved resinous zeolite, sizes and capacities as scheduled on Contract Drawings.

- B. Each unit shall operate at flow rates as scheduled on Contract Drawings with pressure loss not exceeding 15 psi during peak flow.

#### 2.04 SOFTENER TANKS

- A. Shall have 50 percent or more freeboard, fabricated and stamped to comply with ASME Boiler and Pressure Vessel Code: Section VIII, "Pressure Vessels," Division 1 for 150 psi working pressure. Structural steel legs shall be welded to the tanks. Tanks shall be sandblasted to bare metal and internally lined with an NSF approved epoxy (PlaSite 7133 or accepted substitution). Exterior shall be coated with a rust preventative prime coat and a high grade solids, polyurethane enamel 1.25-1.5 mils DFT. Tanks shall have a manhole in the top head. The lower distribution system shall be 4-inch epoxy-coated header with galvanized laterals located to equally distribute flow and require only one layer of gravel. The upper distributor shall be baffle type.
  - 1. For FRP softener tanks: tank construction shall be FRP one-piece seamless molded vessel, 100psi working pressure and 150psi test pressure design. Lower distributor system shall consist of a full flow non-clogging PVC slotted distributor tube. The tank shall be non-code rated for 100 psig working pressure.
  - 2. For steel softener tanks: tank construction shall be welded construction of tank-quality carbon steel. The tank(s) shall have threaded openings for pipe connections and an 11 x 15 minimum manway in the top head for 36" tank diameter and larger. (For 30" tank diameter and smaller: two 4" x 6" handholes shall be provided, one in the top head and one in the lower side shell). The tanks shall be non-code rated for 100psig; Support legs shall be strap-type with mounting holes permanently welded to the to the lower tank head. Tanks 48" and above shall have four angle legs with mounting holes. The tanks shall have exterior epoxy coated 6-8 mils DFT and interior protected with cold-set epoxy with a minimum 10-12 mils DFT. Upper distributor system shall be a single point baffle constructed of Schedule 40/80 PVC on vessels 42" diameter and smaller, and a four point baffle on larger vessels. Lower distributor system shall be of the hub and radial design, constructed of PVC with 0.010 slotted SDR laterals and covered with a subfill of 1/8 x 1/16 washed gravel.

#### 2.05 EXCHANGE RESIN

- A. Shall be NSF approved virgin high-capacity sulfonated polystyrene type stable over the entire pH range with good resistance to bead fracture from attrition or osmotic shock. Each cubic foot of resin shall be capable of removing 30,000 grains of hardness as calcium carbonate when regenerated with 15 pounds of sodium chloride and 20,000 grains of hardness as calcium carbonate when regenerated with 6 pounds of sodium chloride.

#### 2.06 BRINE SYSTEM

- A. The brining system tank and cover shall of a polyethylene construction or molded of corrosion-free fiberglass reinforced phenolic resin with a minimum thickness capable of containing the brine and salt.



- B. A brine regeneration system shall be provided which shall automatically introduce brine into the softeners, close to prevent the entrance of air and refill the brine tank with the proper amount of make-up water. The brine tank will be equipped with a float operated shut-off to measure the proper amount of make-up water into the brine tank and prevent brine tank overflow.

## 2.07 VALVES AND PIPING

- A. Each softener shall have automatic diaphragm type valve nest, slow opening and closing and free of water hammer. The pressure-actuated valves shall move from one position to another without friction. There shall be no contact between dissimilar metals within the valves. Parts subject to wear shall be replaceable using common tools. The valve nest shall be assembled by manufacturer of the softening equipment. The brine valve shall be equipped with an automatic self-adjusting brine injector to draw brine and rinse at a constant rate regardless of water pressure in the 30 to 100 psi range. Each valve nest shall have water sampling cocks and pressure gauges on the inlet and outlet. The operating valve system shall include header, service/regeneration valve and auxiliary service valves as sized on Contract Drawings.
- B. For softeners with 21" diameter and smaller FRP mineral tanks: The main operating valves shall be 5-cycle, automatic hydraulically balanced piston, seal and spacer type to independently pilot service flow and regeneration. Valve body shall be of solid lead-free brass. Valve shall have a minimum hydrostatic pressure of 300psig and a working pressure of 125psig at a temperature range of 34-110 F.
- C. The water softener control shall be programmable to operate as metered or time clock system with extreme flexibility and time of regeneration. The controller shall operate on 120v/60Hz single phase.
- D. For softeners with mineral tanks larger than 21" diameter: The main operating valves shall be a nest of individual diaphragm valves. The valves shall have molded glass-filled Noryl bodies. All internal parts in contact with media shall be made from composite materials with EPDM seals. Valves shall be provided with position indicators to verify whether the valve is open or closed. No special tools shall be required to service the valves. Valves are hydraulically operated.
- E. Control system shall be a NEMA 4X rated factory mounted and wired electrical enclosure with all timing and sequencing controls for each softener, manufactured and provided by the same vendor providing the water treatment hardware. An industrial grade PLC and color touch screen operator interface shall be provided. The operator interface will display flow rates, flow totalization, system status (service, regeneration, standby), local fault messages, individual valve position, as well as allow adjustments to each regeneration step. The PLC will also be programmed to allow the operator to place any step of regeneration (backwash, brine draw, and fast rinse) on hold. The operator can also advance any step of regeneration via operator interface. The PLC will allow the softeners to regenerate on timed basis as well as metered flow, via operator interface. The controller shall operate on 120v/60Hz single phase.
- F. The PLC will provide a common alarm with dry contacts for remote indication. The panel will also have an audible alarm. All alarm conditions will be displayed with text on the operator interface screen.

- G. Inlet and outlet service valves shall provide full flow with minimum pressure drop. All piping shall be galvanized steel or copper. Dielectric couplings shall be provided for all dissimilar metal connections.
- H. The main operating valve and manifold piping shall be factory assembled and shipped attached to the tanks. Piping shall be Type "L" copper as specified within Section 22 10 00. Solder shall contain no lead. Manifold piping shall be arranged with sufficient quantity of unions and flanges to allow removal of valves and servicing of the softener system equipment without the need to cut piping or disassemble more than three joints.
- I. Provide dielectric isolation device where copper lines connect to ferrous lines or equipment.
- J. Dielectric waterway fittings shall have zinc electroplated steel pipe body with LTHS high temperature stabilized polyolefin polymer liner, manufactured by Victaulic, Style 47, Precision Plumbing Products or approved equal.
- K. Brine piping shall be non-metallic (PVC, CPVC, or Polypropylene).

#### 2.08 LINE SHUT-OFF VALVES

- A. Potable water line shut-off valves shall be as specified within Section 22 00 00.
- B. Valves within brine piping shall corrosion resistant and recommended for this use by the manufacturer.

#### 2.09 CONTROLS

- A. The controls shall have adjustable duration of the various steps in regeneration, allow for pushbutton start and provide for complete manual operation.
- B. Regeneration shall be initiated by an insertion-type pulse generator and an installation fitting (tee/saddle) compatible with the specified piping to house the sensor, providing ease of removal for inspection without disruption of the piping system. A 25-foot cable shall be provided for direct connection to the electronic control device. A low voltage signal output from the flow sensor shall transmit flow rate and volume totalization data directly to the electronic water treatment controller. Accuracy shall be  $\pm 1$  percent over the full range and repeatable to  $\pm 0.5$  percent of all range. One flow sensor shall be on the soft water outlet of each tank. Lockouts shall be provided to keep more than one tank at a time from going into regeneration.

- C. Fully-integrated, factory-mounted, programmable microprocessor-driven electronic water treatment controller with integral multiported pilot control valve shall be provided to initiate a backwash/regeneration sequence based on an external signal/batching device. The controller shall be manufactured by the same manufacturer as the water treatment equipment. The multiported pilot control valve shall be factory pretubed to the main operating valve and include a dial for both visual indication of the system status and manual operation in the event of a power failure. The same controller shall sequence all steps of regeneration and return to a service or standby mode. Regeneration shall be controlled by actual hardness or by a flow volume control that is based on the hardness of the water to be softened. The initiating quality and/or volume setpoints shall reset upon regeneration of the system. The user selected program shall operate with manufacturer defaults or with user, customized parameter, all of which will be retained in a nonvolatile memory requiring no external power source or battery backup. All programming shall be accomplished via a color-coded moisture-resistant keypad with actual words and phrases displayed in a prompting manner for all operating procedures. The controller shall be programmable to operate as parallel progressive or alternating. Operator shall be able to reset all data currently in memory back to preset values at any time. Provide two sets of dry from "C" contacts for remote indication of WATER SOFTENER TROUBLE.
- D. Electric wiring for the system shall be provided by the supplier of the water softener equipment.
- E. Flow controls for backwash and flush shall be fully automatic requiring no field adjustment.

#### 2.10 REGENERATION SEQUENCE

- A. The regeneration shall be in this order: backwash, brine, slow rinse, fast downflow flush, service standby.

### PART 3 - EXECUTION

#### 3.01 INSTALLATION

- A. Installation shall meet or exceed all applicable federal, state and local requirements, referenced standards and conform to codes and ordinances of authorities having jurisdiction.
- B. All installation shall be in accordance with manufacturer's published recommendations.
- C. Install system components according to manufacturer's published recommendations and pipe as indicated on Drawings.
- D. Care shall be exercised in fabricating plumbing lines to avoid all cross connections eliminate the possibility of water contamination.
  - 1. Provide and install double check valve assembly backflow prevention on the potable water line serving the water softener downstream of all potable water connections serving any other outlets or equipment.
  - 2. Backflow preventers shall be duplexed where located within lines serving in-patient areas, critical research areas, and/or any area or equipment where un-interruptible (twenty-four hour) water service is required.

3. Provide a physical air gap of at least two times the diameter of the softener equipment drain piping discharging into a floor drain/sink receptor.
- E. Provide 4" thick reinforced concrete housekeeping pad beneath softener and brine tanks. Pad shall extend minimum 4" beyond equipment bases. Thoroughly coat top and sides of pad with three coats of epoxy prior to setting tanks.
- F. Provide all supports required by the equipment and piping included in the system.
- G. Install piping to allow for expansion and Contraction without stressing pipe or equipment connected.
- H. Provide code approved transition adapters when joining dissimilar piping materials.
- I. Provide dielectric isolation device where copper lines connect to ferrous lines or equipment, such as dielectric union, coupling or dielectric flange fitting.
- J. Install valves with stems upright or horizontal, not inverted.

### 3.02 TESTING

- A. Water testing set shall be furnished for hardness test, complete with metal container for all mounting.

### 3.03 INSTRUCTION AND START-UP

- A. A complete set of operating instructions covering the installation, maintenance and operation of the softener system shall be furnished bound in booklet form.
- B. Provide for the service of a competent supervising agent from the water softener manufacturer to inspect the completed installation, start the water softening system in operation and acquaint the operators with the proper operation and maintenance of the equipment.

### 3.04 PERFORMANCE DEMONSTRATION

- A. At the time of Substantial Completion of the system, demonstrate the proper installation and operation of the equipment specified herein by cycling the water softeners through a complete regeneration sequence, checking for proper sequence and valve operation, as well as electrical and mechanical controls. Notify Owner 48 hours in advance of the demonstration.

END OF SECTION 22 31 16



SECTION 22 63 14

LABORATORY COMPRESSED AIR SYSTEM

PART 1 GENERAL

1.01 RELATED DOCUMENTS

- A. Drawings and general provisions of the Contract, including General Conditions and Division 01 Specification Sections, apply to this Section.
- B. Specifications throughout all Divisions of the Project Manual are directly applicable to this Section, and this Section is directly applicable to them.

1.02 SECTION INCLUDES

- A. Pipe and pipe fittings.
- B. Air compressor system.
- C. Air receiver and accessories.
- D. Aftercooler.
- E. Air dryer.
- F. Pressure reducing station.

1.03 RELATED SECTIONS

- G. Section 23 00 00 – Basic Mechanical Requirements.
- H. Section 23 05 29 – Sleeves, Flashings, Supports and Anchors.
- I. Division 26 – Wiring Devices, Cable, Wire and Connectors.

1.04 REFERENCES

- A. ASME - Boiler and Pressure Vessel Code.
- B. ASME B16.18 - Cast Bronze Solder-Joint Pressure Fittings.
- C. ASME B16.22 - Wrought Copper and Bronze Solder-Joint Pressure Fittings.
- D. ASME B16.26 - Cast Bronze Fittings for Flared Copper Tubes.
- E. ASME B31.1 - Power Piping.
- F. ASME B31.9 - Building Services Piping.
- G. ASTM B32 - Solder Metal.
- H. ASTM B88 - Seamless Copper Water Tube.
- I. NFPA 70 - National Electrical Code.

1.05 SUBMITTALS

- A. Submit under provisions of Division 01 and specification section 23 00 00.
- B. Shop Drawings: Indicate piping system schematic with electrical characteristics and connection requirements.
- C. Product Data: Provide manufacturers catalog literature with capacity, weight, and electrical characteristics and connection requirements. Include complete control panel wiring diagrams.
- D. Test Reports: Submit inspector's certificate for air receiver for inclusion in Operating and Maintenance Manuals.
- E. Manufacturer's Installation Instructions: Indicate hoisting and setting requirements, starting procedures.

1.06 PROJECT RECORD DOCUMENTS

- A. Submit under provisions of Division 01 and/or specification section 23 00 00.
- B. Record actual locations of equipment and components. Modify shop drawings to indicate final locations.

1.07 OPERATION AND MAINTENANCE DATA

- A. Submit under provisions of Division 01 and/or specification section 23 00 00.
- B. Operation Data: Submit for air compressors, air receiver and accessories, after cooler, air dryer, and pressure reducing station.
- C. Maintenance Data: Submit for air compressors, air receiver and accessories, after cooler, air dryer, and pressure reducing station.

1.08 REGULATORY REQUIREMENTS

- A. Conform to ASME codes for installation of pressure vessels.
- B. Products Requiring Electrical Connection: Listed and classified by Underwriters' Laboratories, Inc., as suitable for the purpose specified and indicated.

1.09 DELIVERY, STORAGE, AND HANDLING

- A. Deliver, store, protect and handle products to site under provisions of Division 01 and/or specification section 23 00 00.
- B. Accept air compressors, air dryer and all components on site in factory fabricated containers with shipping skids and plastic pipe end protectors in place. Inspect for damage.
- C. Protect piping and equipment from weather and construction traffic.

1.10 WARRANTY

- A. Provide five year warranty under provisions of Division 01 and/or specification section 23 00 00..
- B. Warranty: Include coverage for air compressors.

1.11 MAINTENANCE MATERIALS

- A. Provide maintenance materials under provisions of Division 01 and/or specification section 23 00 00..

PART 2 PRODUCTS

2.01 LABORATORY FITTINGS

- A. Laboratory fittings will be furnished to the job site by the Laboratory Equipment Supplier, with necessary holes cut in the laboratory equipment. Receive, store, and install the fittings and make all necessary connections thereto.

2.02 PIPING

- A. ASTM Specification B-88, Type K, hard drawn, seamless copper tubing with wrought copper solder fittings. No ferrous piping will be permitted in the system. Where threaded nipples are required, use I.P.S. brass. Make all joints with 95/5 (tin/autimony) solder.

### 2.03 SHUT-OFF VALVES

- A. Nibco Model No. T-585-70-66 two piece bronze body ball valve, full port design, 600 psig WOG pressure rating, stainless steel stem and ball with screwed joints and Teflon seats. Equivalent valves by other domestic manufacturers will be acceptable.

### 2.04 AIR COMPRESSOR

- A. Provide and install a multi-core stage, air-cooled, oil free, scroll type air compressor, complete with electronic controller, pre-filter and after-filter. Unit shall have a high efficiency TEFC motor with Class F insulation, 80 dB (A) maximum sound level, totally prepackaged in housing from factory with motor starter. Inlet filter shall be 5-micron cartridge type with housing while outlet filter shall be 1-micron cartridge type with housing. Controller shall continually monitor the status of the core units. Controller shall be capable of sequencing-in core units, and controller shall monitor as a minimum, unit on/off, run hours, and emergency shutdown complete with after-coolers for each compressor, individual compressor unit alternation and lead lag configuration for each packaged unit. All filters shall have differential pressure gauges. Refer to plumbing drawings for schedules. Manufactured by Squire Cogswell, Atlas Copco or Powerex.
- B. Unit shall be provided with a set of dry contacts and a 4-20 mA signal for remote monitoring for the following:
  - 1. Compressor Status.
  - 2. Compressor Failure Alarm.

### 2.05 DESICCANT COMPRESSED AIR DRYERS

- A. Dryer shall be a twin tower absorption/regenerative desiccant type able to deliver air with a constant -40°F dewpoint. Dryer shall be fully automatic with a 0.3 micron cartridge type prefilter and a 0.1 micron cartridge type after-filter, purge exhaust mufflers, dewpoint monitor and carbon monoxide monitor. All filters shall have differential pressure gauges. Unit shall have a power on/off switch and light, ASME relieve valve, with factory installed gauge on inlet and outlet with automatic purge saving control. Unit shall have factory installed activated alumina desiccant cartridges, and upper shuttle valve.
- B. Entire air dryer shall be totally factory pre-packaged factory tested prior to shipment and shall be mounted on skid. Manufactured by Arrow Zander Hankison, Airtek or Atlas Copco.
- C. Provide set of dry contacts of remote signaling for the following:
  - 1. High Humidity Alarm.
  - 2. On/Off Status.

### 2.06 RECEIVER

- A. Fabricated vertical ASME coded steel vessel, conforming to requirement set forth in ASME, 200 psig WP with slight glass, epoxy lining and manual and electronic timed solenoid valve condensate dump valve. Unit shall have 120-gallon capacity, complete with safety valve, automatic drain, 0-150 psi pressure gauge with inspection manhole.

### 2.07 AUTOMATIC DRAINS

- A. Drain shall be mechanically activated automatic type condensate drain.
- B. Body shall be coated for corrosion resistance. Shell shall be constructed of steel and seals shall be Viton.
- C. Rated for maximum working pressure to 200 psi.
- D. Automatic drain shall consist of pilot valve, piston, float, magnet and valve stem.
- E. Drains shall be routed to floor drain.
- F. Manufactured by Hankison.

## 2.08 PRESSURE REGULATING VALVES

- A. Zinc die cast body, diaphragm – operated, direct-acting, spring-loaded, manual pressure setting adjustment, with Buna-N diaphragm and seals, complete with 0-160 psi pressure gauge, rated for 250 psi inlet pressure, manufactured by Aro “Challenger Series”.

## 2.09 SAFETY VALVE

- A. Safety valves shall be ASME coded, pressure vessels constructions, National Board-certified, labeled, and factory seal, constructed of bronze body with poppet safety valve, for compressed air service.
- B. Pressure setting shall be set at 130 psi.

## 2.10 GAUGES

- A. Bourdon tube type, with stainless steel spring, suspended movement, 316 stainless bourdon tube, with minimum 2-1/2-inch dial, shatter-proof gas window with stainless steel case, 1/4-inch NPT brass socket connection, 1 percent full scale accuracy and shall be made in accordance with ASME 40.1 grade 1A, scale range 0-160 psi, Figure intervals at 20 psi, and minor divisions at 2 psi increment, manufactured by Terice No. 700 series, or approved equal.

## 2.11 MISCELLANEOUS COMPONENTS

- A. Provide a weatherproof outside air intake line through roof, as noted on drawings. Provide the following accessories for each compressor: isolation valves, pressure relief valves, inlet and discharge check valves, regulators, pressure reducing valves, gauge glass and ball float valves, pressure switches, flow control valves, solenoid valves, strainers, shock arrestors, flexible connections, flow switches, gauges and other required accessories for a complete and fully functional and operational system.

## 2.12 TESTS

- A. Test all compressed air piping with oil-free and moisture-free dry nitrogen or compressed air at 150 psig. Repair leaks and repeat test until system is proven tight for an 8 hour period. Tests are to be witnessed by Owner’s Representative.

## PART 3 EXECUTION

### 3.01 INSTALLATION

- A. Install equipment in accordance with manufacturer’s instructions.
- B. Install compressor unit on concrete housekeeping pad. Refer to Section 23 00 00.
- C. Install compressor unit on vibration isolators. Level and bolt in place. Refer to Section 23 05 48.
- D. Make air cock and drain connection on horizontal casing.
- E. Install line size gate or ball valve (depending on size), and a check valve on compressor discharge.
- F. Install replaceable cartridge type filter silencer of adequate capacity for each compressor.
- G. Place shut off valve on water inlet to aftercooler. Pipe drain to floor drain.
- H. Connect condensate drains to nearest floor drain.
- I. Install valved bypass around air dryer. Factory insulate inlet and outlet connections.
- J. Install valved drip connections at low points of piping systems.
- K. Install take offs to outlets from top of main, with shut off valve after take off. Slope take off piping to outlets.
- L. Install compressed air couplings, female quick connectors, and pressure gauges where outlets are indicated.

- M. Install tees instead of elbows at changes in direction of piping. Fit open end of each tee with plug.
- N. Identify and label piping system and components. Refer to Section 23 05 53.

3.02 FIELD QUALITY CONTROL

- A. Field inspection and testing will be performed under provisions of Section 23 00 00 (including Uniform General Conditions as referenced therein).
- B. Compressed Air Piping Leak Test: Prior to initial operation, clean and test compressed air piping in accordance with ANSI B31.1.
- C. Repair or replace compressed air piping as required to eliminate leaks, and retest to demonstrate compliance.
- D. Cap (seal) ends of piping when not connected to mechanical equipment.

END OF SECTION 22 63 14



SECTION 23 00 00

BASIC MECHANICAL REQUIREMENTS

PART 1 GENERAL

1.01 SECTION INCLUDES

- A. Basic Mechanical Requirements specifically applicable to Division 23 Sections.

1.02 RELATED DOCUMENTS:

- A. All work covered by this Section of these Specifications shall be accomplished in accordance with all applicable provisions of the Contract Documents and any addenda or directives which may be issued herewith, or otherwise.

1.03 GENERAL:

- A. The Contractor shall execute all work hereinafter specified or indicated on accompanying Drawings. Contractor shall provide all equipment necessary and usually furnished in connection with such work and systems whether or not mentioned specifically herein or on the Drawings.
- B. The Contractor shall be responsible for fitting his material and apparatus into the building and shall carefully lay out his work at the site to conform to the structural conditions, to avoid all obstructions, to conform to the details of the installation and thereby to provide an integrated satisfactory operating installation.
- C. The Mechanical, Electrical, and Plumbing associated Drawings are necessarily diagrammatic by their nature, and are not intended to show every connection in detail or every pipe or conduit in its exact location. These details are subject to the requirements of standards referenced elsewhere in these specifications, and structural and architectural conditions. The Contractor shall carefully investigate structural and finish conditions and shall coordinate the separate trades in order to avoid interference between the various phases of work. Work shall be organized and laid out so that it will be concealed in furred chases and suspended ceilings, etc., in finished portions of the building, unless specifically noted to be exposed. All exposed work shall be installed parallel or perpendicular to the lines of the building unless otherwise noted.
- D. When the mechanical and electrical Drawings do not give exact details as to the elevation of pipe, conduit and ducts, the Contractor shall physically arrange the systems to fit in the space available at the elevations intended with proper grades for the functioning of the system involved. Piping, exposed conduit and the duct systems are generally intended to be installed true and square to the building construction, and located as high as possible against the structure in a neat and workmanlike manner. The Drawings do not show all required offsets, control lines, pilot lines and other location details. Work shall be concealed in all finished areas.

1.04 DEFINITIONS: (Note: These definitions are included here to clarify the direction and intention of this specification. The list given here is not by any means complete. For further clarification as required, contractor shall contact the designated Owner's representative.)

- A. CONCEALED / EXPOSED: Concealed areas are those areas which cannot be seen by the building occupants. Exposed areas are all areas which are exposed to view by the building occupants, including under counters, inside cabinets and closets, plus all mechanical rooms.
- B. General Requirements: The provisions of requirements of other Division 01 sections apply to entire work of contract and, where so indicated, to other elements which are included in project. Basic contract definitions are included in the General Conditions.

- C. Indicated: The term "indicated" is a cross reference to graphic representations, notes or schedules on drawings, to other paragraphs or schedules in the Specifications, and to similar means of recording requirements on contract documents. Where terms such as "shown", "noted", "scheduled", and "specified" are used in lieu of "indicated", it is for the purpose of helping reader locate the cross reference, and no limitation of location is intended except as specifically noted.
- D. Directed, requested, etc.: Where not otherwise explained, terms such as "directed", "requested", "authorized", "selected", "approved", "required", "accepted", and "permitted" mean directed by Architect/Engineer, "requested by Architect/Engineer" and similar phrases. However, no such implied meaning will be interpreted to extend Architect's/Engineer's responsibility into Contractor's area of construction supervision and job safety.
- E. And/Or: Where "and/or" is used in these Specifications or on the Drawings, it shall mean "that situations exist where either one or both conditions occur or are required and shall not be interpreted to permit an option on the part of the Contractor.
- F. Approve: Where used in conjunction with Architect's/Engineer's response to submittals, requests, applications, inquiries, reports and claims by Contractor, the meaning of term "approved" will be held to limitations to Architect's/Engineer's responsibilities and duties as specified in General and Supplementary Conditions. In no case will "approval" by Architect/Engineer be interpreted as a release of Contractor from responsibilities to fulfill requirements of contract documents or to extend Architect's/Engineer's responsibility into Contractor's area of construction supervision and job safety.
- G. As required: Where "as required" is used in these Specifications or on the drawings, it shall mean "that situations exist that are not necessarily described in detail or indicated that may cause the contractor certain complications in performing the work described or indicated. These complications entail the normal coordination activities expected of the Contractor where multiple trades are involved and new or existing construction causes deviations to otherwise simplistic approaches to the work to be performed. The term shall not be interpreted to permit an option on the part of the Contractor to achieve the end result."
- H. Furnish:
  - 1. The term "furnish" is used to mean "supply and deliver to project site, ready for unloading, unpacking, assemble, installation, and similar operations."
  - 2. Where "furnish" applies to work for which the installation is not otherwise specified, "furnish" in such case shall mean "furnish and install."
- I. Install: The term "install" is used to describe operations at project site including "unloading, unpacking, assembly, erection, placing, anchoring, applying, working to dimension, finishing, curing, protecting, cleaning and similar operation."
- J. Provide: The term "provide" means "to furnish and install, complete and ready for intended use."

1.05 PERMITS, UTILITY CONNECTIONS AND INSPECTIONS:

- A. All work performed on this project is under the authority of the State of Texas, therefore no local construction fees or construction permits will be required except as may be required for new service taps, or new or modified connections to City controlled services. If inspections by City personnel are specifically required by this document, refer to Division 01 for responsibility.
- B. Compliance: The Contractor shall comply in every respect with all requirements of National Fire Protection Association, local Fire Department regulations and utility

company requirements. In no case does this relieve the Contractor of the responsibility of complying with these Specifications and Drawings where specified conditions are of higher quality than the requirements of the above-specified authorities. Where requirements of the Specifications and Drawings are more lenient than the requirements of the above authorities having jurisdiction, the Contractor shall make installations in compliance with the requirements of the above authorities with no extra compensation.

1.06 CONTRACT DOCUMENTS:

- A. All dimensional information related to new structures shall be taken from the appropriate Drawings. All dimensional information related to existing facilities shall be taken from actual measurements made by the Contractor on the site.
- B. The interrelation of the Specifications, the Drawings, and the schedules are as follows: The Specifications determine the nature and setting of the several materials, the Drawings establish the quantities, dimensions and details, and the schedules give the performance characteristics. If the Contractor requires additional clarification, he shall request it in writing, following the contractually prescribed information flow requirements.
- C. Should the Drawings or Specifications conflict within themselves, or with each other, the better quality, or greater size or quantity of work or materials shall be performed or furnished.

1.07 SUBMITTALS

- A. Refer to Uniform General Conditions Article 8.
- B. Proposed Products List: Include Products specified in all the contract documents to include drawings and specifications.
- C. Submit shop drawings and product data grouped to include complete submittals of related systems, products, and accessories in a single submittal.
- D. Mark dimensions and values in units to match those specified.
- E. Submit Fabrication Drawings whenever (1) equipment proposed varies in physical size and arrangement from that indicated on the Drawings, thus causing rearrangement of equipment space, (2) where tight spaces require extreme coordination between ductwork, piping, conduit, and other equipment, (3) where called for elsewhere in these Specifications; and (4) where specifically requested by the Architect/Engineer. Fabrication Drawings shall be made at no additional charge to the Owner or the Architect/Engineer.
- F. All required Fabrication Drawings, except as noted otherwise, shall be prepared at a scale of not less than 1/4" = 1'-0". Fabrication Drawings for ductwork, air handling units, and sections in Mechanical Rooms shall be drawn at a minimum scale of 3/8" = 1'-0". Submit three blueline prints of each Fabrication Drawing to the Architect/Engineer for review. Reproduction and submittal of the Construction Documents is not acceptable. The Architect/Engineer will review the drawing and return one print with comments.

1.08 SUBSTITUTION OF MATERIALS AND EQUIPMENT:

- A. Refer to General Conditions for substitution of materials and equipment.
- B. General: Within thirty days after the date of contract award or work order, whichever is later, and before purchasing or starting installation of materials or equipment, the Contractor shall submit for review, a complete list of suppliers, contractors and manufacturers for all materials and equipment which will be submitted for incorporation into the project. The list shall be arranged in accordance with the organization of the Specifications. This initial list shall include the manufacturer's name and type or catalog

number as required to identify the quality of material or equipment proposed. This list will be reviewed by the Engineer and the Owner and will be returned to the Contractor with comments as to which items are acceptable without further submittal data and which items will require detailed submittal data for further review and subsequent approval. The initial list shall be submitted as herein specified. Materials and equipment requiring detailed submittal data shall be submitted with sufficient data to indicate that all requirements of these Specifications have been met and samples shall be furnished when requested. All manufacturer's data used as part of the submittal shall have all inapplicable features crossed out or deleted in a manner that will clearly indicate exactly what is to be furnished.

- C. It is not the intent of the Drawings and/or Specifications to limit products to any particular manufacturer nor to discriminate against an "APPROVED EQUAL" product as produced by another manufacturer. Some proprietary products are mentioned to set a definite standard for acceptance and to serve as a reference in comparison with other products. When a manufacturer's name appears in these Specifications, it is not to be construed that the manufacturer is unconditionally acceptable as a provider of equipment for this project. The successful manufacturer or supplier shall meet all of the provisions of the appropriate specification(s).
- D. The specified products have been used in preparing the Drawings and Specifications and thus establish minimum qualities with which substitutes must at least equal to be considered acceptable. The burden of proof of equality rests with the Contractor. The decision of the designer is final.
- E. When requested by the Architect/Engineer, the Contractor shall provide a sample of the proposed substitute item. In some cases, samples of both the specified item and the proposed item shall be provided for comparison purposes.
- F. Timeliness: The burden of timeliness in the complete cycle of submittal data, shop Drawings, and sample processing is on the Contractor. The Contractor shall allow a minimum of six (6) weeks time frame for review of each submission by the office of the design discipline involved after receipt of such submissions by that design discipline. The Contractor is responsible for allowing sufficient time in the construction schedule to cover the aforementioned cycles of data processing, including time for all resubmittal cycles on unacceptable materials, equipment, etc. covered by the data submitted. Construction delays and/or lack of timeliness in the above regard are the responsibility of the Contractor and will not be considered in any request for scheduled construction time extensions and/or additional costs to the Owner.
- G. All equipment installed on this project shall have local representation, local factory authorized service, and a local stock of repair parts.
- H. Acceptance of materials and equipment will be based on manufacturer's published data and will be tentative subject to the submission of complete shop Drawings indicating compliance with the contract documents and that adequate and acceptable clearances for entry, servicing, and maintenance will exist. Acceptance of materials and equipment under this provision shall not be construed as authorizing any deviations from the Specifications, unless the attention of the Architect/Engineer has been directed in writing to the specific deviations. Data submitted shall not contain unrelated information unless all pertinent information is properly identified.
- I. Certification: The Contractor shall carefully examine all data forwarded for approval and shall sign a certificate to the effect that the data has been carefully checked and found to be correct with respect to dimensions and available space and that the equipment complies with all requirements of the Specifications.

- J. Physical Size of Equipment: Space is critical; therefore, equipment of larger sizes than shown, even though of specified manufacturer, will not be acceptable unless it can be demonstrated that ample space exists for proper installation, operation, and maintenance.
- K. Materials and Equipment Lists: Eight (8) copies of the list of materials and equipment, the name of manufacturer, trade name, type, and catalog number shall be submitted to the Architect/Engineer. The lists shall be accompanied by eight (8) sets of pictorial and descriptive data derived from the manufacturers' catalogs, sales literature, or incorporated in the Shop Drawings.
- L. Should a substitution be accepted, and should the substitute material prove defective, or otherwise unsatisfactory for the service intended within the guarantee period, this material or equipment shall be replaced with the material or equipment specified at no additional cost to the Owner.

1.09 MATERIALS AND WORKMANSHIP:

- A. All materials, unless otherwise specified, shall be new, free from all defects, suitable for the intended use, and of the best quality of their respective kinds. Materials and equipment shall be installed in accordance with the manufacturer's recommendations and the best standard practice for the type of work involved. All work shall be executed by mechanics skilled in their respective trades, and the installations shall provide a neat, precise appearance. Materials and/or equipment damaged in shipment or otherwise damaged prior to installation shall not be repaired at the job site but shall be replaced with new materials and/or equipment.
- B. The responsibility for the furnishing of the proper equipment and/or material and seeing that it is installed as intended by the manufacturer, rests entirely upon the Contractor who shall request advice and supervisory assistance from the representative of specific manufacturers during the installation.

1.10 FLAME SPREAD PROPERTIES OF MATERIALS:

- A. Materials and adhesives incorporated in this project to be installed within return air plenums shall conform to NFPA Standard 255, "Method of Test of Surface Burning Characteristics of Building Materials" and NFPA 90. The classification shall not exceed a flame spread rating of 25 for all materials, adhesives, finishes, etc., specified for each system, and shall not exceed a smoke developed rating of 50.

1.11 REGULATORY REQUIREMENTS

- A. The "Authority Having Jurisdiction" over the project described by these documents is the Owner, as an Agency of the State of Texas. As such, it is required that the installation shall meet the minimum standards prescribed in the latest editions of the following listed codes and standards, which are made a part of these Specifications. All referenced codes and standards shall be those current at the date of issue of the design documents.
- B. National Fire Protection Association Standards (NFPA):
  - 1. NFPA No. 13, Sprinkler System, Installation
  - 2. NFPA No. 14, Standpipes and Hose Systems
  - 3. NFPA No. 20, Centrifugal Fire Pumps
  - 4. NFPA No. 37, Stationary Combustion Engines & Gas Turbines
  - 5. NFPA No. 45, Fire Protection for Laboratories Using Chemicals
  - 6. NFPA No. 51, Welding & Cutting, Oxygen-Fuel Gas Systems



7. NFPA No. 54, Gas Appliances, Piping, National Fuel Gas Code
  8. NFPA No. 70, National Electrical Code
  9. NFPA No. 72D, Proprietary Signaling Systems
  10. NFPA No. 78, Lightning Protection Code
  11. NFPA No. 90A, Air Conditioning Systems
  12. NFPA No. 91, Blower & Exhaust Systems
  13. NFPA No. 99, Health Care Facilities
  14. NFPA No. 101, Life Safety Code
  15. NFPA No. 200, Series, Building Construction
  16. NFPA No. 255, Method of Test of Surface Burning Characteristics of Building Materials
  17. NFPA No. 258, Standard Research Test Method for Determining Smoke Generation of Solid Materials
- C. American National Standards Institute (ANSI):
1. A40.8, National Plumbing Code
  2. B31.1, Power Piping
  3. B9.1, Safety Code for Mechanical Refrigeration
- D. American Gas Association Publications (AGA): Directory of Approved Gas Appliances and Tested Accessories
- E. American Society of Mechanical Engineers (ASME): Boiler and Pressure Vessel Codes
- F. Air Conditioning and Refrigeration Institute Standards (ARI): All standards related to refrigeration and air conditioning equipment and piping furnished under these Specifications.
- G. Sheet Metal and Air Conditioning Contractors National Association, Inc. (SMACNA): All current editions of applicable manuals and standards (See Sections 23 31 00.UT and 23 33 00.UT).
- H. Air Moving and Conditioning Association (AMCA): All current editions of applicable manuals and standards.
- I. American Society of Testing Materials (ASTM): All current editions of applicable manuals and standards.
- J. American Water Works Association (AWWA): All current editions of applicable manuals and standards.
- K. National Electrical Manufacturers' Association (NEMA): All current editions of applicable manuals and standards.
- L. City of Houston, Fire Department as may be applicable to construction on this site.
- M. International Building Code, (Includes the International Mechanical and International Plumbing Codes)
- N. Texas Occupational Safety Act: All applicable safety standards
- O. Occupational Safety and Health Act (OSHA)

- P. ADA and ANSI Standards: All work shall be in accord with all regulations and requirements of the Standards and Specifications for Handicapped and Disabled for the Construction of Public Buildings and Facilities in the State of Texas Usable by Physically Handicapped and Disabled persons, ANSI Standards and the requirements of the American Disabilities Act.
- Q. Texas State Fire Marshal Rules
- R. State Energy Code – ASHRAE 90.1 – 2012.
- S. Ventilation Standard – ASHRAE 62.1 – 2012.
- T. Refer to Specification Sections hereinafter bound for additional Codes and Standards.
- U. All materials and workmanship shall comply with all applicable state and national codes, Specifications, and industry standards. In all cases where Underwriters' Laboratories, Inc. has established standards for a particular type material, such material shall comply with these standards. Evidence of compliance shall be the UL "label" or "listing" under Re-Examination Service.
- V. The Contract Documents are intended to comply with the aforementioned rules and regulations; however, some discrepancies may occur. Where such discrepancies occur, the Contractor shall immediately notify the Architect/Engineer in writing of said discrepancies and apply for an interpretation. Should the discovery and notification occur after the execution of a contract, any additional work required for compliance with said regulations shall be paid for as covered by Division 01 of these Contract Documents, providing no work of fabrication of materials has been accomplished in a manner of noncompliance. Should the Contractor fabricate and/or install materials and/or workmanship in such a manner that does not comply with the applicable codes, rules and regulations, the Contractor who performed such work shall bear all costs arising in correcting these deficiencies to comply with said rules and regulations.

1.12 GENERAL MATERIALS AND EQUIPMENT REQUIREMENTS:

- A. Storage at Site: The Contractor shall not receive material or equipment at the job site until there is suitable space provided to properly protect equipment from rust, drip, humidity, and dust damage.
- B. Capacities shall be not less than those indicated but shall be such that no component or system becomes inoperative or is damaged because of startup or other overload conditions.
- C. Conformance with Agency Requirements: Where materials or equipment are specified to be approved, listed, tested, or labeled by the Underwriters' Laboratories, Inc., or constructed and/or tested in accordance with the standards of the American Society of Mechanical Engineers or the Air Moving and Conditioning Association, the Contractor shall submit proof that the items furnished under this Section of the Specifications conform to such requirements. The label of the Underwriters Laboratories, Inc., applied to the item will be acceptable as sufficient evidence that the items conform to such requirements. The ASME stamp or the AMCA label will be acceptable as sufficient evidence that the items conform to the respective requirements.
- D. Nameplates: Each major component of equipment shall have the manufacturer's name, address, and catalog number on a plate securely attached to the item of equipment. All data on nameplates shall be legible at the time of Final Inspection.
- E. Prevention of Rust: Standard factory finish will be acceptable on equipment specified by model number; otherwise, surfaces of ferrous metal shall be given a rust inhibiting coating. The treatment shall withstand 200 hours in salt spray fog test, in accordance

with Method 6061 of Federal Standard No. 141. Immediately after completion of the test, the specimen shall show no signs of wrinkling or cracking and no signs of rust creepage beyond 1/8" on either side of the scratch mark. Where rust inhibitor coating is specified hereinafter, any treatment that will pass the above test is acceptable unless a specific coating is specified except that coal tar or asphalt type coating will not be acceptable unless so stated for a specific item. Where steel is specified to be hot-dip galvanized, mill-galvanized sheet steel may be used provided all raw edges are painted with a zinc-pigmented paint conforming to Military Specification MIL-P-26915.

- F. Protection from Moving Parts: Belts, pulleys, chains, gears, couplings, projecting set screws, keys, and other rotating parts shall be fully enclosed or properly guarded for personnel protection.
  - G. Verification of Dimensions: The Contractor shall be responsible for the coordination and proper relation of his work to the building structure and to the work of all trades. The Contractor shall visit the premises and become thoroughly familiar with all details of the work and working conditions, to verify all dimensions in the field, and to advise the Architect/Engineer of any discrepancy before performing any work. Adjustments to the work required in order to facilitate a coordinated installation shall be made at no additional cost to the Owner or the Architect/Engineer.
  - H. All mechanical and Plumbing equipment that is to be controlled or monitored by the building automation system shall be BACnet compatible.
- 1.13 WALL, FLOOR AND CEILING PLATES:
- A. See Section 23 05 29.
- 1.14 SLEEVES, INSERTS, AND FASTENINGS:
- A. See Section 23 05 29.
- 1.15 PROJECT/SITE CONDITIONS
- A. Install Work in locations shown on Drawings, unless prevented by Project conditions.
  - B. Prepare drawings showing proposed rearrangement of Work to meet Project conditions, including changes to Work specified in other Sections. Obtain permission of Architect/Engineer before proceeding.
- 1.16 MANUFACTURER'S RECOMMENDATIONS
- A. The manufacturer's published directions shall be followed in the delivery, storage, protection, installation, piping, and wiring of all equipment and material. The Contractor shall promptly notify the Architect/Engineer, in writing, of any conflict between the requirements of the Contract Documents and the manufacturers' directions, and shall obtain the Architect/Engineer's instructions before proceeding with the work. Should the Contractor perform any such work that does not comply with the manufacturers' directions or such instructions from the Architect/Engineer, he shall bear all costs arising in connection with the deficiencies.
- 1.17 SPACE AND EQUIPMENT ARRANGEMENT:
- A. The size of mechanical and electrical equipment indicated on the Drawings is based on the dimensions of a particular manufacturer and a particular model. While other manufacturers and models may be acceptable, it is the responsibility of the Contractor to determine if the equipment he proposes to furnish will fit in the space with all adequate clearances. Fabrication Drawings shall be prepared when required by the Architect/Engineer or Owner to indicate a suitable arrangement.

- B. All equipment shall be installed in a manner to permit access to all surfaces. All valves, motors, drives, filters, and other accessory items shall be installed in a position to allow removal for service without disassembly of another part.

1.18 LARGE APPARATUS:

- A. Any large piece of apparatus which is to be installed in any space in the building, and which is too large to permit access through stairways, doorways, or shafts shall be brought to the job and placed in the space before the enclosing structure is completed. Following placement in the space, such apparatus shall be thoroughly, completely protected from damage as hereinafter specified.

1.19 PROTECTION:

- A. The Contractor shall at all times take such precautions as may be necessary to properly protect all materials and equipment from damage from the time of delivery until the completion of the work. This shall include the erection of all required temporary shelters and supports to adequately protect any items stored in the open on the site from the weather, the ground and surrounding work; the cribbing of any items above the floor of the construction; and the covering of items in the incomplete building with tarpaulins or other protective covering; the installation of electric heaters in electrical switchgear and similar equipment to prevent moisture damage. Failure on the part of the Contractor to comply with the above will be sufficient cause for the rejection of the items in question.
- B. Take particular care not to damage the building structure in performing work. All finished floors, step treads, and finished surfaces shall be covered to prevent any damage by workmen or their tools and equipment during the construction of the building.
- C. Equipment and materials shall be protected from rust both before and after installation. Any equipment or materials found in a rusty condition at the time of final inspection must be cleaned of rust and repainted as specified elsewhere in these Specifications.

1.20 COOPERATION BETWEEN TRADES AND WITH OTHER CONTRACTORS:

- A. Each trade, subcontractor, and/or Contractor must work in harmony with the various other trades (including Controls and Testing and Balancing), subcontractors and/or Contractors on the job as may be required to facilitate the progress to the best advantage of the job as a whole. Each trade, subcontractor, and/or Contractor must pursue its work promptly and carefully so as not to delay the general progress of the job. This Contractor shall work in harmony with Contractors working under other contracts on the premises.

1.21 ELECTRICAL WIRING OF MOTORS AND EQUIPMENT:

- A. The Contractor shall note that the electrical design and Drawings are based on the equipment scheduled and indicated on the Drawings, and should any mechanical equipment be provided requiring changes to the electrical design, the required electrical changes shall be made at no cost to the Owner.
- B. The Electrical Trades shall provide all interconnecting wiring for the installation of all power. The Electrical Trades shall provide all disconnect switches as required for proper operation, as indicated on the Drawings or required by applicable code. All combination starters, individual starters, and other motor starting apparatus not specifically scheduled or specified as provided by the equipment manufacturer under the scope of Division 23, shall be provided under the scope of Division 26.
- C. The Mechanical Trades shall provide complete wiring diagrams indicating power wiring and interlock wiring. Diagrams shall be submitted to the Architect/Engineer for review within thirty (30) days after the submittals for equipment have been reviewed. Diagrams shall be based on accepted equipment and shall be complete full phase and interlock

control Drawings, not a series of manufacturer's individual diagrams. After these diagrams have been reviewed by the Architect/Engineer, copies shall be transmitted to the Electrical Trades by the Contractor. They shall be followed in detail.

1.22 SUPERVISION:

- A. Each Contractor and subcontractor shall keep a competent superintendent or foreman on the job at all times. (Refer to the Uniform General Conditions for additional information concerning supervision.)
- B. It shall be the responsibility of each superintendent to study all Drawings and familiarize himself with the work to be done by other trades. He shall coordinate his work with other trades and before material is fabricated or installed, make sure that his work will not cause an interference with another trade. Where interferences are encountered, they shall be resolved at the job site by the superintendents involved. Where interferences cannot be resolved without major changes to the Drawings, the matter shall be referred to the A/E for ruling.

1.23 SITE OBSERVATION:

- A. Site observation by the Architect/Engineer is for the express purpose of verifying compliance by the Contractor with the Contract Documents, and shall not be construed as construction supervision nor indication of approval of the manner or location in which the work is being performed as being a safe practice or place.

1.24 PRECEDENCE OF MATERIALS

- A. The specifications determine the nature and setting of materials and equipment. The drawings establish quantities, dimensions and details.
- B. The installation precedence of materials shall be as follows. Note that if an interference is encountered, this shall guide the contractor in the determination of which trade shall be given the "Right-of-Way".

Building lines

Structural Members

Soil and Drain Piping

Condensate Drains

Vent Piping

Supply, Return, and Outside Air Ductwork

Exhaust Ductwork

HVAC Water and Steam Piping

Steam Condensate Piping

Fire Protection Piping

Natural Gas Piping

Domestic Water (Cold and Hot)

Refrigerant Piping

Electrical Conduit

1.25 CONNECTIONS FOR OTHERS:



- A. The Mechanical Contractor shall rough in for and make all gas, water, steam, sewer, etc. connections to all fixtures, equipment, machinery, etc., provided by others in accordance with detailed roughing-in Drawings provided by the equipment suppliers, by actual measurements of the equipment connections, or as detailed.
- B. After the equipment is set in place, this Contractor shall make all final connections and shall provide all required pipe, fittings, valves, traps, etc.
- C. Provide all air gap fittings required, using materials hereinbefore specified. In each service line connected to an item of equipment or piece of machinery, provide a shutoff valve. On each drain not provided with a trap, provide a suitable trap.
- D. All pipe fittings, valves, traps, etc., exposed in finished areas and connected to chrome plated lines provided by others shall be chrome plated to match.
- E. Provide all sheet metal ductwork, transition pieces, etc., required for a complete installation of vent hoods, fume hoods, etc., provided by others.

1.26 INSTALLATION METHODS:

- A. Where to Conceal: All pipes, conduits, etc., shall be concealed in pipe chases, walls, furred spaces, or above the ceilings of the building unless otherwise indicated.
- B. Where to Expose: In mechanical rooms, janitor's closets tight against pan soffits in exposed "Tee" structures, or storage spaces, but only where necessary, piping may be run exposed. All exposed piping shall be run in the most aesthetic, inconspicuous manner, and parallel or perpendicular to the building lines.
- C. Support: All piping, ducts and conduits shall be adequately and properly supported from the building structure by means of hanger rods or clamps to walls as herein specified.
- D. Maintaining Clearance: Where limited space is available above the ceilings below concrete beams or other deep projections, pipe and conduit shall be sleeved through the projection where it crosses, rather than hung below them in a manner to provide maximum above-floor clearance. Sleeves shall be as herein specified. Approval shall be obtained from the Architect/Engineer for each penetration.
- E. All pipe, conduits, etc., shall be cut accurately to measurements established at the building and shall be worked into place without springing or forcing. All ducts, pipes and conduits run exposed in machinery and equipment rooms shall be installed parallel to the building lines, except that piping shall be sloped to obtain the proper pitch. Piping, ducts and conduits run in furred ceilings, etc., shall be similarly installed, except as otherwise shown. Conduits in furred ceilings and in other concealed spaces shall be neatly grouped and racked indicating good workmanship. All conduit and pipe openings shall be kept closed until the systems are closed with final connections.
  - 1. All piping not directly buried in the ground shall be considered as "interior piping".
  - 2. Prior to the installation of any ceiling material, gypsum, plaster, or acoustical board, the Contractor shall notify the construction inspector so that arrangement can be made for an inspection of the above-ceiling area about to be "sealed" off. The Contractor shall give as much advance notice as possible no less than 10 working days.
  - 3. All above-ceiling areas will be subject to a formal inspection before ceiling panels are installed, or installation is otherwise concealed from view. All mechanical and electrical work at and above the ceiling, including items supported by the ceiling grid, such as air inlets or outlets and lighting fixtures, shall be complete and installed in accordance with contract requirements, including power to lighting fixtures, fans, and other powered items. Adequate lighting shall be

provided to permit thorough inspection of all above-ceiling items. The inspection will include representatives of the following: General Contractor and each Subcontractor having work above the ceiling, Architect/Engineer, Physical Plant, Resident Construction Manager's Construction Inspector(s), the Resident Construction Manager and Office of Facilities Planning and Construction (OFPC). Areas to be included and time of inspection shall be coordinated with the Construction Inspector.

4. The purpose of this inspection is to verify the completeness and quality of the installation of the air conditioning systems, the electrical systems, the plumbing systems, and any other special above ceiling systems such as pneumatic tube, vacuum systems, fire sprinkler piping and cable tray systems. The ceiling supports (tee bar or lath) shall be in place so that access panel and light fixture locations are identifiable and so that clearances and access provisions may be evaluated.
5. No ceiling materials may be installed until the resulting deficiency list from this inspection is worked off and the Construction Inspector has given approval.

1.27 RECORDS FOR OWNER:

- A. The Contractor shall maintain a set of "blueprint" prints in the Field Office for the sole purpose of recording "installed" conditions. Daily note all changes made in these Drawings in connection with the final installation including exact dimensioned locations of all new underground utilities, services and systems and all uncovered existing active and inactive piping outside the building.
- B. At Contract completion the Contractor shall provide a set of reproducible revised drawings per Division 01. The contractor shall transfer the information from the "blueprint" prints maintained as described above, and turn over this neatly marked set of reproducible Drawings representing the "as installed" work to the Architect/Engineers for verification and subsequent transmittal to the Owner. The Contractor shall refer to Division 01 of these Specifications, and to the Uniform General Conditions, for additional information. These Drawings shall include as a minimum:
  1. Addendum written drawing changes.
  2. Addendum supplementary drawings.
  3. Accurate, dimensioned locations of all underground utilities, services and systems.
  4. Identification of equipment work shown on Alternates as to whether alternates were accepted and work actually installed.
  5. Change Order written drawing changes.
  6. Change Order supplementary drawings.
- C. In addition to the above, the Contractor shall accumulate during the progress of the job the following data, in duplicate, prepared in a neat brochure or packet folder and turn over to the Architect/Engineer for review, and subsequent delivery to the Owner.
  1. All warranties and guarantees and manufacturers' directions on equipment and material covered by the Contract.
  2. Two sets of operating instructions for heating and cooling and other mechanical and electrical systems. Operating instructions shall also include recommended preventative maintenance and seasonal changeover procedures.
  3. Valve tag charts and diagrams specified herein.

4. Approved wiring diagrams and control diagrams representing "as installed" conditions.
  5. Copies of approved Shop Drawings.
  6. Any and all other data and/or drawings required as submittals during construction.
  7. Repair parts list of all major items and equipment including name, address and telephone number of local supplier or agent.
- D. All of the above data shall be submitted to the Architect/Engineer for approval, and shall be corrected as instructed by the Architect/Engineer.
- 1.28 ACCESS DOORS:
- A. General: This Contractor shall provide wall or ceiling access doors for unrestricted access to all concealed items of mechanical equipment or devices.
  - B. Doors: Access doors mounted in painted surfaces shall be of Milcor (Inland-Ryerson Construction Products Company) manufacture, Style K for plastered surfaces and Style M or DW for non-plastered surfaces. The Style K doors shall be set so that the finished surface of the door is even with the finished surface of the adjacent finishes. Access doors mounted on tile surfaces shall be of similar construction as noted above, except they shall be of stainless steel materials. Access doors shall be a minimum of 12" x 12" in size.
- 1.29 CHECKING AND TESTING MATERIALS AND/OR EQUIPMENT:
- A. Before the work is accepted, an authorized representative of the manufacturer of the installed materials and/or equipment shall personally inspect the installation and operation of his materials and/or equipment to determine that it is properly installed and in proper operating order. The qualifications of the representative shall be appropriate to the technical requirements of the installation. The qualifications of the representative shall be submitted to the owner for approval. The decision of the owner concerning the appropriateness of the representative shall be final. Testing and checking shall be accomplished during the course of the work where required by work being concealed, and at the completion of the work otherwise. In addition, the Contractor shall submit to the Architect/Engineer a signed statement from each representative certifying as follows: "I certify that the materials and/or equipment listed below have been personally inspected by the undersigned authorized manufacturer's representative and is properly installed and operating in accordance with the manufacturer's recommendations".
  - B. Check inspections shall include plumbing equipment, heating, air conditioning, insulation, ventilating equipment, controls, mechanical equipment and such other items hereinafter specified or specifically designated by the Architect/Engineer.
- 1.30 TESTS:
- A. The Contractor shall make, at no additional cost to the Owner, any tests deemed necessary by the inspection departments having jurisdiction, and in the National Fire Protection Association, ASTM, etc. Standards listed. The Contractor shall provide all equipment, materials, and labor for making such tests. Reasonable amounts of fuel and electrical energy costs for system tests will be paid by the Owner. Fuel and electrical energy costs for system adjustment and tests which follow beneficial occupancy by the Owner will be borne by the Owner.
  - B. Additional tests specified hereinafter under the various Specification Sections shall be made.

- C. The Construction Inspector shall be notified in writing at least 10 working days prior to each test and other Specification requirements requiring action on the part of the Construction Inspector. All equipment shall be placed in operation and tested for proper automatic control requirements before the balancing agency starts their work.
- D. Maintain Log of Tests as hereinafter specified.
- E. See Specifications hereinafter for additional tests and requirements.

1.31 LOG OF TESTS:

- A. All tests shall have pertinent data logged by the Contractor at the time of testing. Data shall include date, time, personnel, description, and extent of system tested, test conditions, test results, specified results, and other pertinent data. Data shall be delivered to the Architect/Engineer as specified under "Requirements for Final Acceptance". All Test Log entries shall be legibly signed by the Project Contractor or his authorized job superintendent.

1.32 COOPERATION AND CLEANUP:

- A. It shall be the responsibility of each trade to cooperate fully with the other trades on the job to help keep the job site in a clean and safe condition. At the end of each day's work, each trade shall properly store all of his tools, equipment and materials and shall clean his debris from the job. Upon the completion of the job, each trade shall immediately remove all of his tools, equipment, any surplus materials and all debris caused by that portion of the work.

1.33 CLEANING AND PAINTING:

- A. All equipment furnished and installed in exposed areas under Divisions 23 and 26 of these Specifications shall be cleaned, prepared, and painted according to the specification for the equipment.
- B. All purchased equipment furnished by the mechanical and electrical subcontractors shall be delivered to the job with a suitable factory protective finish with the colors hereinafter specified. The following materials shall not be painted: copper, galvanized metal, stainless steel, fiberglass, PVC, and PVDF.
- C. Before painting, materials and equipment surfaces shall be thoroughly cleaned of cement, plaster, and other foreign materials, and all oil and grease spots shall be removed. Such surfaces shall be carefully wiped and all cracks and corners scraped out. Exposed metal work shall be carefully brushed down with the steel brushes to remove rust and other spots and left smooth and clean.
- D. Jacketing on insulation shall not be painted.
- E. No nameplates on equipment shall be painted, and suitable protection shall be afforded to the plates to prevent their being rendered illegible due to the painting operation.
- F. Scope of painting for Division 23 and 26 work in areas other than those defined as "exposed" is as follows:
  - 1. All canvas finishes including those underfloor and in concealed spaces shall be painted with one sizing coat if not already sized, containing mildew resistant additive and Arabol adhesive prior to any other specified finish paint.
  - 2. All fuel piping (natural gas, LPG, etc.) and all fire protection piping shall be painted whether concealed or exposed, in all areas of the project without exception. Fuel piping shall be painted safety yellow, and fire protection piping shall be painted safety red. These "safety" colors shall be as defined by OSHA. Primer and first color coat may be omitted on piping above ceilings.

3. If insulated, the piping shall be primed, only, prior to insulation, and the insulation jacketing shall be painted as specified for piping. The requirements of this paragraph are "primary" and have priority over any conflicting specification or instruction, should a conflict in the Construction Documents exist.
- G. The surfaces to be finish painted shall first be prepared as follows:
1. On canvas finishes pretreat as specified above. Insulated surfaces having vapor barrier jacket exposed to view shall first be painted with one (1) coat of sealer.
  2. Galvanized and black steel surfaces shall first be painted with one (1) coat of P&L galvanized metal primer. Primer may be eliminated on concealed fire and gas piping.
  3. Aluminum surfaces shall first be painted with one (1) coat of P&L zinc chromate primer. (See Section 1.51.5)
  4. Cast iron pipe shall first be primed with a "nonbleed" primer.
  5. The underside of all cast iron sinks not recessed in a cabinet are included as items to be painted in exposed areas.
- H. Where factory applied finishes are damaged in transit, storage or installation, or before final acceptance, they shall be restored to factory fresh condition by competent refinishers using the spray process.

## PART 2 PRODUCTS

NOT USED

## PART 3 EXECUTION

### 3.01 PIPE PRESSURE TESTS:

- A. The following lines shall be tested 1.5 times working pressure or at least at the following stated pressure for the length of time noted:

<u>Service</u>	<u>Testing</u>		
	<u>Testing Medium</u>	<u>Pressure (PSIG)</u>	<u>Time in Hours</u>
Domestic Hot & Cold Water	Water	150	24
Sanitary Piping	Water	Fill to top	24

- B. Where leaks occur, the pipe shall be repaired and the tests repeated. No leaks shall be corrected by peening. Defective piping and joints shall be removed and replaced.

END OF SECTION

SECTION 23 05 29

SLEEVES, FLASHINGS, SUPPORTS AND ANCHORS

PART 1 GENERAL

- 1.01 The following sections are to be included as if written herein:
- A. Section 23 00 00 – Basic Mechanical Requirements
  - B. Section 23 05 53 – Mechanical Identification
- 1.02 SECTION INCLUDES
- A. Pipe and equipment hangers and supports
  - B. Equipment bases and supports
  - C. Sleeves and seals
  - D. Flashing and sealing equipment and pipe stacks
- 1.03 RELATED SECTIONS
- A. Section 23 00 00 - Basic Mechanical Requirements
  - B. Section 22 62 21 - Laboratory Vacuum Pump Systems
- 1.04 1.05 REFERENCES
- A. ASME B31.1 - Power Piping
  - B. ASME B31.2 - Fuel Gas Piping
  - C. ASME B31.5 - Refrigeration Piping
  - D. ASME B31.9 - Building Services Piping
  - E. ASTM F708 - Design and Installation of Rigid Pipe Hangers
  - F. MSS SP58 - Pipe Hangers and Supports - Materials, Design and Manufacturer
  - G. MSS SP69 - Pipe Hangers and Supports - Selection and Application
  - H. MSS SP89 - Pipe Hangers and Supports - Fabrication and Installation Practices
  - I. NFPA 13 - Installation of Sprinkler Systems
  - J. NFPA 14 - Installation of Standpipe and Hose Systems
  - K. UL 203 - Pipe Hanger Equipment for Fire Protection Service
- 1.05 SUBMITTALS
- A. Submit under provisions of Section 23 00 00.
  - B. Shop Drawings: Indicate system layout with location and detail of trapeze hangers.
  - C. Product Data: Provide manufacturers catalog data including load capacity.
  - D. Design Data: Indicate load carrying capacity of trapeze, multiple pipe, and riser support hangers.
  - E. Manufacturer's Installation Instructions: Indicate special procedures and assembly of components.
- 1.06 REGULATORY REQUIREMENTS
- A. Conform to applicable code for support of plumbing, hydronic, steam and steam condensate piping.
  - B. Supports for Sprinkler Piping: Shall be in conformance with NFPA 13.
  - C. Supports for Standpipes: Shall be in conformance with NFPA 14.

PART 2 PRODUCTS

- 2.01 HANGERS AND SUPPORTS
- A. Manufacturers:
    - 1. Grinnell.



2. Kindorf
  3. B-Line
  4. Power Strut
- B. Supports, hangers, anchors and guides shall be provided for all horizontal and vertical piping. Shop Drawings shall be provided, indicating locations and details of anchors, guides, expansion loops and joints, hangers, etc. The hanger design shall conform to the ASME Code for Pressure Piping.
  - C. All auxiliary steel required for supports, anchors, guides, etc. shall be provided by the Mechanical Trades unless specifically indicated to be provided by others.
  - D. The supports, hangers, anchors, and guides for the chilled water supply and return piping, steam piping, condensate return piping, etc. of the Campus Loop System routed through utility tunnels and below buildings shall be provided as indicated on the Drawings.
  - E. Contractor shall review all Drawings, including Structural Drawings, for details regarding pipe supports, anchors, hangers, and guides.
  - F. All Supports shall be of type and arrangement to prevent excessive deflection, to avoid excessive bending stresses between supports, and to eliminate transmission of vibration.
  - G. All rod sizes indicated in this Specification are minimum sizes only. This trade shall be responsible for structural integrity of all supports, anchors, guides, etc. All structural hanging materials shall have a minimum safety factor of 5 built in.
  - H. Anchor points as indicated on Drawings or as required shall be located and constructed to permit the piping system to take up its expansion and contraction freely in opposite directions away from the anchored points.
  - I. Guide points shall be located and constructed wherever required or indicated on Drawings and at each side of an expansion joint or loop, to permit free axial movement only.
  - J. Supports, hangers, anchors, and guides shall be fastened to the structure only at such points where the structure is capable of restraining the forces in the piping system.
  - K. Hangers supporting and contacting brass or copper lines 3" in size and smaller shall be Grinnell Fig. CT-99c, adjustable, copper plated, tubing ring. Hangers supporting and contacting brass or copper lines 4" and larger shall be Grinnell Fig. 260, adjustable clevis, with a nut above and below the hanger, and approved neoprene isolating material between pipe (or tubing) and hanger on the support rod. For insulated copper or brass domestic water lines, hangers for all sizes of pipe shall be Grinnell Fig. 300, adjustable clevis, with a nut above and below the hanger, and approved neoprene isolating material between pipe (or tubing) and hanger on the support rod. Isolate all copper or brass lines from all ferrous materials with approved dielectric materials. Hangers supporting and contacting plastic or glass piping shall be of equal design, but shall be padded with neoprene material or equal. The padding material and the configuration of its installation shall be submitted for approval.
  - L. Hangers supporting insulated lines where the outside diameter of the insulation is the equivalent of 8" diameter pipe or smaller in size and supporting all ferrous lines 6" and smaller in size shall be Grinnell Fig. 260, adjustable clevis, with a nut above and below the hanger on the support rod.
  - M. Hangers supporting and contacting ferrous lines larger than 6" in size and outside of insulation on lines with the outside diameter equivalent to 10" diameter pipe shall be Grinnell Fig. 260, adjustable clevis, with a nut above and below the hanger on the support rod.
  - N. Other special type of hangers may be employed where so specified or indicated on the Drawings, or where required by the particular conditions. In any case, all hangers must be acceptable to the owner.
  - O. Each hanger shall be properly sized to fit the supported pipe or fit the outside of the insulation on lines where specified. Hangers for dual or low temperature insulation pipes

- shall bear on the outside of the insulation, which shall be protected by support shields as specified in Section 23 07 19 - PIPING INSULATION. Protect insulation from crushing by means of a section of rigid insulation to be installed at hanger points. Hangers for high temperature insulated pipes and all insulated hot and cold domestic water pipes shall be encased in the insulation unless supported by trapezes in which case shield and rigid insulation shall be provided as specified above for low temperature insulated pipes.
- P. Supports for vertical piping in concealed areas shall be double bolt riser clamps, Grinnell Fig. 261, or other approved equal, with each end having equal bearing on the building structure, and located at each floor. Two-hole rigid pipe clamps at 4 ft. o.c. or Kindorf channels and Grinnell Fig. 261 riser clamps may be used to support pipe directly from vertical surfaces or members where lines are not subject to expansion and contraction. When piping is subject to expansion and contraction, provide spring isolators (see Section 23 05 48 - Vibration Isolation). Where brass or copper lines are supported on trapeze hangers or Kindorf channels the pipes shall be isolated from these supports with plastic tape with insulating qualities, or strut clamps as manufactured by Specialty Products Company, Stanton, California.
- Q. Supports for vertical piping in exposed areas (such as fire protection standpipe in stairwells) shall be attached to the underside of the building structure above the top of the riser, and the underside of the penetrated structure. The contractor shall use a drilled anchor as specified above, and use a Grinnell No. 595 Socket Clamp with Grinnell No. 594 Socket Clamp Washers, as a riser clamp. The top riser hanger shall consist of two (2) hanger rods (sized as specified) anchored to the underside of the building structure, supporting the pipe by means of the material specified. Risers penetrating floors shall be supported from the underside of the penetrated floor as specified for the top of the riser.
- R. Pipe Supports in Chases and Partitions: Horizontal and vertical piping in chases and partitions shall be supported by hangers or other suitable support. Pipes serving plumbing fixtures and equipment shall be securely supported near the point where pipes penetrate the finish wall. Supports shall be steel plate, angles, or special channels such as Unistrut mounted in vertical or horizontal position. Pipe clamps such as Unistrut P2426, P2008, P1109 or other approved clamps shall be attached to supports. Supports shall be attached to wall or floor construction with clip angles, brackets, or other approved method. Supports may be attached to cast iron pipe with pipe clamp, or other approved method. All copper or brass lines shall be isolated from ferrous metals with dielectric materials to prevent electrolytic action.
- S. All electrical conduits shall be run parallel or perpendicular to adjacent building lines. Single conduits running horizontally shall be supported by "Caddy" or "Minerallac" type hangers from adequately sized rods (minimum 1/4") from the building structure. Where multiple conduits are run horizontally, they shall be supported on trapeze of "Unistrut" type channel suspended on rods or bolted to vertical building members. Conduit shall be secured to channel with galvanized "Unistrut" type conduit clamps or stainless steel "Unistrut" type "Uni-Clips." All hangers shall be fastened to the building structure in the same manner as specified above for pipe hangers. Spacing of hangers shall be adequate for the weight and rigidity of the conduits involved; in any case, no greater than 8' centers. Where feasible, conduits may be fastened to the concrete by one-hole straps thoroughly anchored to the concrete in an approved manner. Flexible conduit shall also be supported in an acceptable manner so as not to interfere with the maintenance of above-ceiling equipment, and to support it from touching the ceiling system. Conduit shall be located so as not to inhibit removal of ceiling tiles. Vertical conduits shall be supported as often as necessary for rigidity by clamps resting on adjacent beams or floor slabs, using a minimum of one support per floor.
- T. Perforated strap iron or wire will not, under any circumstances, be acceptable as hanger material.

- U. Vibration Isolation: Resilient hangers shall be provided on all piping connected to rotating equipment (pumps, etc.). Piping or ductwork that may vibrate and create an audible noise shall also be isolated. Spring hangers or supports shall be provided where indicated on the Drawings and/or specified under Section 23 05 48.
- V. Attachment:
1. The load and spacing on each hanger and/or insert shall not exceed the safe allowable load for any component of the support system, including the concrete which holds the inserts. Reinforcement at inserts shall be provided as required to develop the strength required.
  2. Inserts shall be of a type which will not interfere with reinforcing as shown on the structural Drawings and which will not displace excessive amounts of structural concrete.
  3. All supports shall be designed and installed to avoid interference with other piping, hangers, ducts, electrical conduit, supports, building structures, equipment, etc. All piping shall be installed with due regard to expansion and contraction and the type of hanger method of support, location of support, etc. shall be governed in part by this Specification.
  4. Hangers shall be attached to the structure as follows:
    - a. Poured In Place Concrete: Where pipes and equipment are supported under poured in place concrete construction, each hanger rod shall be fitted with a nut at its upper end, which nut shall be set into an Underwriters Laboratories, Inc. listed universal concrete insert placed in the form work before concrete is poured. Where inserts are placed in the bottom faces of concrete joists which are too narrow to provide adequate strength of concrete to hold the insert properly or where a larger insert would require displacement of the bottom joist steel, the hanger rod shall be suspended from the center of a horizontal angle iron, channel iron, I-beam, etc. spanning across two adjacent joists. The horizontal support shall be bolted to nonadjustable concrete inserts of the "spot" type, of physical size small enough to avoid the bottom joist steel.
    - b. Steel Bar Joists: Where pipes and loads are supported under bar joists, hanger rods may be run through the space between the bottom angles and secured with a washer and two nuts. Where larger lines are supported beneath bar joists, hanger rods shall be secured to angle irons of adequate size; each angle shall span across two or more joists as required to distribute the weight properly and shall be welded to the joists or otherwise permanently fixed thereto.
    - c. Steel Beams: Where pipes and loads are supported under steel beams, approved type beam clamps shall be used.
    - d. If it is necessary to install a method of fastening a hanger after the structure has been installed, then only clamps or drilled anchors shall be used.
      - 1) Power-actuated fasteners (shooting) will not be acceptable under any circumstances.
      - 2) Note: Under no circumstances will the use of plastic anchors or plastic expansion shields be permitted for any purpose whatsoever.
- W. Trapezes: Where multiple lines are run horizontally at the same elevation and grade, they may be supported on trapezes of Kindorf, Uni-Strut, Power Strut, or approved equal, channel-suspended on rods or pipes. Trapeze members including suspension rods shall each be properly sized for the number, size, and loaded weight of the lines they are to support.
- X. Finishes: All hangers on piping including clevis hangers, rods, inserts, clamps, stanchions, and brackets, shall be dipped in Zinc Chromate Primer before installation.

- Rods may be galvanized or cadmium plated after threading, in lieu of dipping zinc chromate. Universal concrete inserts shall be cadmium plated.
- Y. Ductwork: All ductwork shall be supported in accordance with the SMACNA recommendation for the service involved; however, all horizontal ductwork shall be supported at intervals not to exceed the scheduled values indicated elsewhere in this section. Horizontal ducts shall be supported using galvanized steel bands extending up both sides and onto the construction above, where they shall turn over and be secured with bolts and nuts fitted in inserts set in the concrete bolted to angles secured to the construction above, or secured in another approved manner. For attaching methods for precast double tee structural concrete, refer to details on the Drawings and as specified herein.
- Z. Terminal units shall be supported by four 16 gauge, 1" wide sheet metal straps with ends turned under bottom of box at corners. Each band shall be secured by not over 3/4" in length, 1/4" diameter sheet metal screws - two on bottom of box and one on side. The other strap end shall be attached to the structure by 1/4" diameter threaded bolt into the concrete insert or into drilled-hole threaded concrete expansion anchor. Where interferences occur, overhead of the box, not allowing direct vertical support by straps, provide trapezes of Kindorf, Unistrut, or B-Line channel suspended by 1/4" diameter galvanized threaded rods providing such channels do not block access panels of boxes. Threaded rods shall be supported from structure by concrete insert or by drilled-hole threaded concrete expansion anchor.
- AA. Miscellaneous: Provide any other special foundations, hangers and supports indicated on the Drawings, specified elsewhere herein; or required by conditions at the site. Hangers and supporting structures for suspended equipment shall be provided as required to support the load from the building structure in a manner acceptable to the Architect/Engineer.

## 2.02 ACCESSORIES

- A. Hanger Rods: Galvanized mild steel threaded both ends, galvanized threaded one end, or galvanized continuous threaded.
- B. Inserts: Malleable iron case of galvanized steel shell and expander plug for threaded connection with lateral adjustment, top slot for reinforcing rods, lugs for attaching to forms; size inserts to suit threaded hanger rods. Suitable concrete inserts for pipe and equipment hangers shall be set and properly located for all pipe and equipment to be suspended from concrete construction. If the inserts are later found not to be in the proper location for the placement of hangers, then drilled anchors shall be installed. Drilled anchors in concrete or masonry shall be submitted for the approval by the Owner.

## 2.03 CONCRETE FOUNDATIONS ("Housekeeping Pads"):

- A. Concrete foundations for the support of equipment such as floor mounted panels, pumps, fans, air handling units, etc., shall extend 4" on all sides beyond the limits of the mounted equipment unless otherwise noted and shall be poured in forms built of new dressed 6" nominal lumber. All corners of the foundations shall be neatly chamfered by means of sheet metal or triangular wood strips nailed to the form. Foundation bolts shall be placed in the forms when the concrete is poured, the bolts being correctly located by means of templates. Each bolt shall be set in a sleeve of size to provide 1/2" clearance around bolt. Allow 1" below the equipment bases for alignment and grouting. After grouting, the forms shall be removed and the surface of the foundations shall be hand rubbed with Carborundum. Foundations for equipment located on the exterior of the building shall be provided as indicated. Foundations shall be constructed in accordance with Shop Drawings submitted by the Contractor for review by the Architect/Engineer.

2.04 WALL, FLOOR AND CEILING PLATES:

- A. Except as otherwise noted, provide C.P. (Chrome plated) brass floor and ceiling plates around all pipes, conduits, etc., passing exposed through walls, floors, or ceilings, in any spaces except underfloor and attic spaces. Plates shall be sized to fit snugly against the outside of the pipe or against the insulation on lines which are insulated and positively secured to such pipe or insulation. Plates will not be required for piping where pipe sleeves extend 3/4" above finished floor. All equipment rooms are classified as finished areas. Round and rectangular ducts shall have closure plates (NOT chrome plated) made to fit accurately at all floor, wall and ceiling penetrations. Floor penetrations in exposed (except in stair wells) areas shall be finished using 'bell' fitting to fit pipe or insulation and sleeve and shall be painted to match the pipe. Penetrations in stairwells shall have flat floor plate painted to match pipe.

PART 3 EXECUTION

3.01 INSTALLATION

- A. Install in accordance with manufacturer's instructions.

3.02 INSERTS

- A. Provide inserts for placement in concrete formwork.
- B. Provide inserts for suspending hangers from reinforced concrete slabs and sides of reinforced concrete beams.
- C. Provide hooked rod to concrete reinforcement section for inserts carrying pipe over 4 inches.
- D. Where concrete slabs form finished ceiling, locate inserts flush with slab surface.
- E. Where inserts are omitted, drill through concrete slab from below and provide through-bolt with recessed square steel plate and nut recessed into and grouted flush with slab.

3.03 PIPE HANGERS AND SUPPORTS

- A. Support horizontal piping as scheduled.
- B. Install hangers to provide minimum 1/2 inch space between finished covering and adjacent work.
- C. Place hangers within 12 inches of each horizontal elbow.
- D. Use hangers with 1-1/2 inch minimum vertical adjustment.
- E. Support horizontal cast iron pipe adjacent to each hub, with 5 feet maximum spacing between hangers.
- F. Support vertical piping at every floor. Support vertical cast iron pipe at each floor at hub.
- G. Where several pipes can be installed in parallel and at same elevation, provide multiple or trapeze hangers.
- H. Support riser piping independently of connected horizontal piping.
- I. Provide copper plated hangers and supports for copper piping.
- J. Design hangers for pipe movement without disengagement of supported pipe.
- K. Prime coat exposed steel hangers and supports. Hangers and supports located in crawl spaces, pipe shafts, and suspended ceiling spaces are not considered exposed, but shall be corrosion protected with galvanized plating. Repair any damaged galvanized plating with a coating of 'Galvalum'.
- L. Hanger Rods: (NOTE: All hanger rods shall be trimmed neatly so that no more than 1 inch of excess hanger rod protrudes beyond the hanger nut. In the event a rod is intentionally but temporarily left excessively long (for sloped or insulated lines for example), the contractor shall take appropriate measures to protect the pipe or other materials from damage.)

3.04 PIPE SUPPORT SCHEDULES

STEEL PIPE SIZE	MAX. HANGER SPACING	HANGER ROD DIAMETER
<u>Inches</u>	<u>Feet</u>	<u>Inches</u>
1/2 to 1-1/4	6.5	3/8
1-1/2 to 2	10	3/8
2-1/2 to 3	10	1/2
4 to 6	10	5/8
8 to 12	14	7/8
14 and Over	20	1
PP, PVDF, PVC, CPVC (All Sizes)	4	3/8
C.I. Bell and Spigot (or No-Hub), <u>and at all Joints</u>	5	5/8
Glass, <u>and at all Joints</u>	4	1/2

END OF SECTION

## SECTION 23 0716 - EQUIPMENT INSULATION

### PART 1 GENERAL

1.1 The following sections are to be included as if written herein:

- A. Section 23 0000 – Basic Mechanical Requirements
- B. Section 23 0529 – Sleeves, Flashings, Supports and Anchors
- C. Section 23 0553 – Mechanical Identification

1.2 SECTION INCLUDES

- A. Equipment insulation
- B. Covering
- C. Breaching insulation

1.3 RELATED SECTIONS

- A. Section - Painting: Painting insulation covering

1.4 REFERENCES

- A. ASTM B209 - Aluminum and Aluminum-Alloy Sheet and Plate
- B. ASTM C177 - Steady-State Heat Flux Measurements and Thermal Transmission Properties by Means of the Guarded- Hot-Plate Apparatus
- C. ASTM C195 - Mineral Fiber Thermal Insulation Cement
- D. ASTM C335 - Steady-State Heat Transfer Properties of Horizontal Pipe Insulation
- E. ASTM C449 - Mineral Fiber Hydraulic-setting Thermal Insulating and Finishing Cement
- F. ASTM C518 - Steady-State Heat Flux Measurements and Thermal Transmission Properties by Means of the Heat Flow Meter Apparatus
- G. ASTM C533 - Calcium Silicate Block and Pipe Thermal Insulation
- H. ASTM C534 - Preformed Flexible Elastomeric Cellular Thermal Insulation in Sheet and Tubular Form
- I. ASTM C552 - Cellular Glass Block and Pipe Thermal Insulation
- J. ASTM C553 - Mineral Fiber Blanket and Felt Insulation
- K. ASTM C612 - Mineral Fiber Block and Board Thermal Insulation
- L. ASTM C640 - Corkboard and Cork Pipe Thermal Insulation
- M. ASTM C921 - Properties of Jacketing Materials for Thermal Insulation
- N. ASTM D1056 - Flexible Cellular Materials - Sponge or Expanded Rubber
- O. ASTM E84 - Surface Burning Characteristics of Building Materials



- P. ASTM E96 - Water Vapor Transmission of Materials
- Q. NFPA 255 - Surface Burning Characteristics of Building Materials
- R. UL 723 - Surface Burning Characteristics of Building Materials

#### 1.5 SUBMITTALS

- A. Submit under provisions of Section 23 0000.
- B. Product Data: Provide product description, list of materials and thickness for equipment scheduled.
- C. Samples: Submit two samples of any representative size illustrating each insulation type.
- D. Manufacturer's Installation Instructions: Indicate procedures which ensure acceptable workmanship and installation standards will be achieved.

#### 1.6 QUALITY ASSURANCE

- A. Materials: Flame spread/smoke developed rating of 25/50 in accordance with NFPA 255.

#### 1.7 QUALIFICATIONS

- A. Applicator: Company specializing in performing the work of this section with minimum three years experience.

#### 1.8 DELIVERY, STORAGE, AND HANDLING

- A. Deliver, store, protect and handle products to site under provisions of Section 23 0000.
- B. Deliver materials to site in original factory packaging, labeled with manufacturer's density and thickness.
- C. Store insulation in original wrapping and protect from weather and construction traffic.
- D. Protect insulation against dirt, water, chemical, and mechanical damage.

#### 1.9 ENVIRONMENTAL REQUIREMENTS

- A. Maintain ambient temperatures and conditions required by manufacturers of adhesives, mastics, and insulation cements.
- B. Maintain temperature during and after installation for minimum period of 24 hours.

### PART 2 PRODUCTS

#### 2.1 HEAT EXCHANGERS, CLEAN STEAM GENERATORS AND HOT WATER GENERATORS (NOT FACTORY INSULATED):

- A. The domestic hot water generator(s) and steam heating hot water converter(s) shall be insulated as hereinafter specified.

- B. Contractor shall install dimensional standard cellular glass insulation, Pittsburgh Corning "FOAMGLAS". The "FOAMGLAS" "StrataFab System" may also be installed as appropriate. "FOAMGLAS" for higher than ambient temperature service shall be manufactured using Pittsburgh Corning Hydrocal B-11 as the joint adhesive between layers of material. Prior to application of any insulation, all metal surfaces shall be thoroughly cleaned. Regular "FOAMGLAS" insulation shall be applied to the piping with butt joints staggered and all joints tightly butted. The insulation shall be held in place using stainless steel bands. The bands shall be spaced at 12 inches on center. A jacket of aluminum or stainless steel shall be applied to the completed installation. The Longitudinal joint of the jacketing shall be placed with overlap directed to bottom of pipe. The jacketing shall be overlapped a minimum of 3 inches, and it shall be held in place using 3/4 inch bands applied at 12 inches on center. Note that the use of asphaltic compounds in higher-than-ambient temperature service is prohibited.
- C. Fitting insulation shall be applied in same manner as pipe application. Refer to piping insulation specification for proper guidance.

- D. The insulation thickness shall be as follows:

Temperature	Thickness
75°F to 150°F	2"
151°F to 300°F	2 1/2"
above 300°F	3"

- E. Securing of the jacket shall be made by the use of 1/2" x 0.016" aluminum or stainless steel bands and seals. The shields at support points shall be secured with 1/2" x 0.020" stainless steel bands and seals. Ferrous metal surfaces shall be primed with a red lead oxide primer. The metal jacketing and fitting covers shall be fabricated of 0.016" aluminum or stainless steel with a smooth finish.

## 2.2 PUMPS:

- A. Each water pump shall be insulated as detailed on the drawings the insulation of the connecting piping shall be continued up to the face of the flanges on the piping connection to the pump and any bare metal that projects over the bed plate of the pump and from which condensation might drip onto the floor.
- B. Receivers of the steam condensate pumps shall be insulated with 6 lb. (minimum) density fiberglass board or rigid wrap insulation with a factory applied All Service Jacket. All joints shall be filled with insulating cement and covered with All Service Jacket material stapled in place and sealed with adhesive. Thickness shall be as scheduled. Steam traps and any uninsulated flash tanks or blow-down separators shall be insulated similar to the condensate receivers.

## 2.3 MISCELANEOUS EQUIPMENT:

- A. Air separators, chemical feeders and expansion tanks shall be insulated as specified for related piping. Re: 23 0719.

## PART 3 EXECUTION

### 3.1 EXAMINATION

- A. Verify that equipment has been tested before applying insulation materials.
- B. Verify that surfaces are clean, foreign material removed, and dry.

### 3.2 INSTALLATION

- A. Install materials in accordance with manufacturer's instructions.
- B. Do not insulate factory insulated equipment.
- C. On exposed equipment, locate insulation and cover seams in least visible locations.
- D. Apply insulation close to equipment by grooving, scoring, and beveling insulation. Secure insulation to equipment with studs, pins, clips, adhesive, wires, or bands.
- E. Fill joints, cracks, seams, and depressions with bedding compound to form smooth surface. On cold equipment, use vapor barrier cement.
- F. Insulated dual temperature equipment or cold equipment containing fluids below ambient temperature:
  - 1. Provide vapor barrier jackets, factory applied or field applied.
  - 2. Finish with glass cloth and vapor barrier adhesive.
  - 3. Insulate entire system.
- G. For insulated equipment containing fluids above ambient temperature:
  - 1. Provide standard jackets, with or without vapor barrier, factory applied or field applied.
  - 2. Finish with glass cloth and adhesive.
  - 3. For hot equipment containing fluids 140 degrees F or less, do not insulate flanges and unions, but bevel and seal ends of insulation.
  - 4. For hot piping conveying fluids over 140 degrees F, insulate flanges and unions, including those at equipment, but label the insulation to indicate a concealed flange or union.
- H. Inserts and Shields:
  - 1. Application: Equipment 2 inches diameter or larger.
  - 2. Shields: Galvanized steel between hangers and inserts.
  - 3. Insert location: Between support shield and equipment and under the finish jacket.
  - 4. Insert configuration: Minimum 6 inches (150 mm) long, of same thickness and contour as adjoining insulation; may be factory fabricated.
  - 5. Insert material: Heavy density insulating material suitable for the planned temperature range.
- I. Finish insulation at supports, protrusions, and interruptions.
- J. For equipment in mechanical equipment rooms or in finished spaces, finish with aluminum jacket.
- K. For exterior applications, provide vapor barrier jacket or finish with glass mesh reinforced vapor barrier cement. Cover with aluminum jacket with seams located on bottom side of horizontal equipment.
- L. Cover cellular glass and cellular foam insulation with aluminum jacket.

- M. Do not insulate over any nameplate or ASME stamps. Bevel and seal insulation around such nameplates..
- N. Install insulation for equipment requiring access for maintenance, repair, or cleaning, in such a manner that it can be easily removed and replaced without damage.
- O. All piping, equipment, ductwork, all plenums including metal and masonry construction, fans, etc., shall be insulated as indicated on the Drawings, as specified herein, and as required for a complete system. In each case, the insulation shall be equal to that specified and materials applied and finished as described in these Specifications.
- P. All insulation shall be applied by mechanics skilled in this particular work and regularly engaged in such occupation. All insulation shall be applied in strict accordance with these Specifications and with factory printed recommendations on items not herein mentioned. Unsightly, inadequate, or sloppy work will not be acceptable, and all such work shall be removed and replaced as many times as necessary to achieve an acceptable installation.
- Q. All insulation, jacket, adhesives, mastics, sealers, etc., utilized in the fabrication of these systems shall meet NFPA for fire resistant ratings (maximum of 25 flame spread and 50 smoke developed ratings) and shall be approved by the insulation manufacturer for guaranteed performances when incorporated into their insulation system, unless a specific product is specified for a specific application, and is stated as an exception to this requirement. Certificates to this effect shall be submitted along with Contractor's submittal data for this section of the Specifications. No material may be used that, when tested by the ASTM E84-89 test method, is found to melt, drip or delaminate to such a degree that the continuity of the flame front is destroyed, thereby resulting in an artificially low flame spread rating.
- R. All surfaces to be insulated shall be clean and dry before applying the insulation. All sections of molded pipe covering shall be firmly butted together. Where an insulation covering is applied, it shall lap the adjoining section of insulation by at least three inches (3"). Where insulation terminates, it shall be neatly beveled and finished. No insulation shall be applied until the pipe, duct, etc., have been pressure tested and found tight. Piping, flexible connections, flanges, valves, strainers, and unions shall be covered unless specifically noted otherwise. Flexible connections on duct shall not be covered. All materials used shall be fire retardant or nonflammable.
- S. Where vapor barriers are required, the vapor barrier shall be on the outside. Extreme care shall be taken that the vapor barrier is unbroken. Joints, etc., shall all be sealed. Where insulation with a vapor barrier terminates, it shall be sealed off with the vapor barrier being continuous to the surface being insulated. Ends shall not be left raw.
- T. Where canvas finish is specified, use Arabol lagging adhesive to prevent mildew in securing canvas. Do not use wheat paste. In addition, cover all canvas insulation with a fire retardant coating.
- U. The handling and installation of all insulation materials shall be performed in strict accordance with the manufacturer's recommendations.

End of Section 23 0716

SECTION 23 07 19  
PIPING INSULATION

PART 1 GENERAL

1.00. The following sections are to be included as if written herein:

A. 23 00 00 -- Basic Mechanical Requirements

1.01. SECTION INCLUDES

A. Piping insulation.

B. Jackets and accessories.

1.02. PRODUCTS FURNISHED BUT NOT INSTALLED UNDER THIS SECTION

A. Section 23 22 00 - Steam Piping: Placement of hangers and hanger inserts.

1.03. RELATED SECTIONS

A. Section 09 91 00 - Painting: Painting pipe and insulation jacket.

B. Section 23 00 00 - General Mechanical Requirements.

1.04. REFERENCES

A. ASTM B209 - Aluminum and Aluminum-Alloy Sheet and Plate.

B. ASTM C177 - Steady-State Heat Flux Measurements and Thermal Transmission Properties by Means of the Guarded- Hot-Plate Apparatus.

C. ASTM C195 - Mineral Fiber Thermal Insulation Cement.

D. ASTM C335 - Steady-State Heat Transfer Properties of Horizontal Pipe Insulation.

E. ASTM C449 - Mineral Fiber Hydraulic-setting Thermal

F. ASTM C518 - Steady-State Heat Flux Measurements and Thermal Transmission Properties by Means of the Heat Flow Meter Apparatus.

G. ASTM C533 - Calcium Silicate Block and Pipe Thermal Insulation.

H. ASTM C534 - Preformed Flexible Elastomeric Cellular Thermal Insulation in Sheet and Tubular Form.

I. ASTM C547 - Mineral Fiber Preformed Pipe Insulation.

J. ASTM C552 - Cellular Glass Block and Pipe Thermal Insulation.

K. ASTM C578 - Preformed, Block Type Cellular Polystyrene Thermal Insulation.

L. ASTM C585 - Inner and Outer Diameters of Rigid Thermal Insulation for Nominal Sizes of Pipe and Tubing (NPS System).

- M. ASTM C591 - Rigid Preformed Cellular Urethane Thermal Insulation.
- N. ASTM C610 - Expanded Perlite Block and Pipe Thermal Insulation.
- O. ASTM C640 - Corkboard and Cork Pipe Thermal Insulation.
- P. ASTM C921 - Properties of Jacketing Materials for Thermal Insulation.
- Q. ASTM D1056 - Flexible Cellular Materials - Sponge or Expanded Rubber.
- R. ASTM D1667 - Flexible Cellular Materials - Vinyl Chloride Polymers and Copolymers (Closed Cell Foam).
- S. ASTM D2842 - Water Absorption of Rigid Cellular Plastics.
- T. ASTM E84 - Surface Burning Characteristics of Building Materials.
- U. ASTM E96 - Water Vapor Transmission of Materials.
- V. NFPA 255 - Surface Burning Characteristics of Building Materials.
- W. UL 723 - Surface Burning Characteristics of Building Materials.

#### 1.05. SUBMITTALS

- A. Submit under provisions of Section 23 00 00.
- B. Product Data: Provide product description, list of materials 'k' value, 'R' value, mean temperature rating, and thickness for each service, and locations.
- C. Samples: When requested, submit two samples of any representative size illustrating each insulation type.
- D. Manufacturer's Installation Instructions: Submit the manufacturer's published installation documents for installation details, support and anchor methods, sealing, installation procedures and installation environment. Indicate procedures which ensure acceptable workmanship and installation standards will be achieved.

#### 1.06. QUALITY ASSURANCE

- A. All insulation, jacket, adhesives, mastics, sealers, etc., utilized in the fabrication of these systems shall meet NFPA for fire resistant ratings (maximum of 25 flame spread and 50 smoke developed ratings) and shall be approved by the insulation manufacturer for guaranteed performances when incorporated into their insulation system, unless a specific product is specified for a specific application, and is stated as an exception to this requirement. Certificates to this effect shall be submitted along with Contractor's submittal data for this section of the Specifications. No material may be used that, when tested by the ASTM E84-89 test method, is found to melt, drip or delaminate to such a degree that the continuity of the flame front is destroyed, thereby resulting in an artificially low flame spread rating.
- B. All surfaces to be insulated shall be clean and dry before applying the insulation. All sections of molded pipe covering shall be firmly butted together without voids. A mastic filler is not acceptable to fill voids. Where an insulation covering is applied, it shall lap the adjoining section of insulation by at least three inches (3") on end sections and the longitudinal tape shall be 4" on jackets. Where insulation terminates, it shall be neatly

beveled and finished moisture proof. No insulation shall be applied until the pipe, duct, etc., have been pressure tested and found tight. Piping, flexible connections, flanges, valves, strainers, and unions shall be covered unless specifically noted otherwise. Flexible connections on duct shall not be covered. All materials used shall be fire retardant or nonflammable. Refer to Section 23 00 00.

- C. No insulation material shall be installed in combination with or contiguous to other types of insulation in a manner which could adversely impact the performance of either insulation material.
- D. All piping, equipment, ductwork, all plenums including metal and masonry construction, fans, etc., shall be insulated as indicated on the Drawings, as specified herein, and as required for a complete system. In each case, the insulation shall be equal to that specified and materials applied and finished as described in these Specifications.
- E. The manufacturer's representative for the insulation shall visit the site a minimum of 4 times to review the installation practices, confer with the installer and prepare a field observation report that notes variations from manufacturer's recommendations or recommendations to improve the installations.
- F To be considered, alternate materials shall have equivalent thermal, permability, water absorption and moisture resistance of the specified materials.

#### 1.07. QUALIFICATIONS

- A. All insulation shall be applied by mechanics skilled in this particular work and regularly engaged in such occupation.
- B. All insulation shall be applied in strict accordance with these Specifications and with factory printed recommendations on items not herein mentioned. Unsightly, inadequate, or sloppy work and torn vapor jackets will not be acceptable and all such work shall be removed and replaced as many times as necessary to achieve an acceptable installation. The company performing the work of this section shall have a minimum of three years experience specializing in the trade.

#### 1.08. DELIVERY, STORAGE, AND HANDLING

- A. Deliver, store, protect, and handle products to site under provisions of Section 23 00 00.
- B. Deliver materials to site in original factory packaging, labeled with manufacturer's identification, including product thermal ratings and thickness.
- C. Store insulation in original wrapping and protect from weather and construction traffic. Protect insulation against dirt, water, chemical, and mechanical damage.

#### 1.09. ENVIRONMENTAL REQUIREMENTS

- A. Maintain ambient temperatures and conditions required by manufacturers of adhesives, mastics, and insulation cements.
- B. Maintain temperature during and after installation for minimum period of 24 hours.
- C. All insulation materials to be asbestos free.



## PART 2 PRODUCTS

### 2.01. DOMESTIC HOT AND COLD WATER AND HEATING HOT WATER:

- A. All domestic hot and cold water lines in buildings, including valves, strainers, unions, flanges, etc., except where specifically noted to the contrary, shall be insulated.
- B. All domestic cold water lines shall be insulated as scheduled with preformed fiberglass insulation with a factory applied All Service Jacket, vapor sealing all joints, and factory performed fittings with vapor seal. For domestic hot and cold a flexible, "25-50" rated, closed cell elastomeric thermal insulation such as "Self Seal Armaflex 2000" is also acceptable. Elastomeric products shall be supplied in a preslit tubular form with a pressure sensitive adhesive system for closure and vapor sealing of the longitudinal joint. All elastomeric insulating products shall be guaranteed not to react with copper piping. Valves shall be insulated with mitered pipe covering with voids filled with glass fiber blanket insulation. Valves and fittings shall be vapor sealed with a water base asphaltic emulsion. Fittings on concealed insulation shall be built up to the thickness of adjacent insulation with glass fiber fitting wrap and shall be finished with Glasfab tape embedded in vapor barrier emulsion. Exposed fitting insulation shall be built up to same thickness as adjoining pipe insulation with one coat cement and after drying shall be finished with a white vapor seal and canvas jacket secured with "Arabol" adhesive and be suitable for painting. Seams in jacket shall be placed in the least noticeable locations. Where seams, joint or fittings are rough they shall be covered with an application of insulating cement trowelled on smoothly before the canvas is applied with Arabol adhesive. The canvas must be free of wrinkles and have a smooth, neat appearance.
- C. All domestic hot water and heating water piping systems shall be insulated as specified above for cold water except the vapor barrier may be deleted and the lap and butt joints secured with staples and a field applied adhesive (self sealing lap and butt joints alone are not acceptable). The insulation thickness shall be as scheduled. Where service temperature exceeds 250°F, insulation shall contain high temp binders.
- D. The only domestic hot and cold water piping that will not require insulation are the exposed runouts under non-handicap plumbing fixtures. Where pipe chases are tight, adequate provision shall be made at the rough in stage utilizing offset fittings or other means (except springing the pipe) to insure that insulation can be applied throughout the length of the pipe.

### 2.03 STEAM AND CONDENSATE PIPING:

- A. Steam and condensate piping in the main loop system and up to and including PRV's and in the building shall be insulated with Manville's Thermo-12 or Owens/Corning "Kaylo" calcium silicate insulation with a factory applied aluminum cover .016" thick (Metal-On). If metal-on factory applied cover is not available, provide a manufacturer's written letter and provide for a field-installed aluminum jacket as specified herein. Joints shall be sealed with aluminum snap straps provided, fastened in place with 3/4" wide x .020" stainless steel bands. Fittings and valves shall be insulated with the same thickness as that applied to the adjacent pipe and shall have an outer removable covering of aluminum as manufactured by Premetco.
- B. Consideration will be given to the use of Manville's Thermo-12 or Owens/Corning "Kaylo" with an outer covering of Premetco smooth finish, pre-cut, pre-rolled, Kraft paper lined aluminum Jacketing with zee type closure and 1-3/4" wide snap strap with permanent sealant in lieu of "Metal-On". Thickness of this jacketing shall be .016" on pipe sizes 8" and smaller and .020" on 10" pipe and larger.

- C. If Premetco jacketing is used, it shall be aluminum banding (.020N thick) using three section of covering
- D. Pipe insulation shall be firmly wired in place by the use of no less than six (6) loops of No. 16 annealed copper clad iron wire per three foot section of insulation. These sections shall be staggered. The ends of these loops shall be twisted together tightly and bent over and hammered into the insulation so as to leave no projection. Bands shall be .020" thick, ¾" wide, 3 bands per section of insulation. Fittings, valves, etc., shall have bands on each side.
- E. All fittings on pipe 4" and larger shall be covered with the same material as the pipe, mitered and smoothed, and securely wired to the pipe.
- F. Fittings and valves for pipe smaller than 4" shall be insulated with Manville's No. 301 hydraulic setting cement and each application shall be in layers not thicker than ½". Each layer shall be allowed to dry before the next layer is applied.
- G. All cracks and voids in this insulation shall be filled carefully with Manville's Cement No. 301 so that the resulting surface is smooth and continuous.
- H. At all pipe flanges, the insulation shall be beveled in such a manner that access may be had to the bolt studs and nuts without injuring the insulation where removable covers have been specified.
- I. A layer of 40 pound rosin-size paper or ¾ pound deadening felt shall be wrapped around the insulation before an 8 ounce canvas jacket is pasted in place. This canvas jacket shall be pasted onto the covered pipe valves and fittings (where insulated) in a neat and workmanlike fashion, using Arabol adhesive.
- J. All flanges, valves, pressure regulating valves, strainers, and any other hot surfaces shall be covered with a built-up removable covering made of Thermo-12 or "Kaylo" Pipe Covering with a finishing coat of Ryder hydraulic setting cement. This removable covering shall be banded on the valve or joint in such a fashion that it can readily be removed and replaced; it shall be of the same thickness as the insulation on the adjoining pipe.
- K. Piping insulated with calcium silicate pipe insulation and finished with canvas outer jacket shall be properly labeled.
- L. Refer to Section 23 05 53 for Mechanical Identification requirements.

#### 2.05. PROTECTIVE JACKETING:

- A. Provide protective jacketing as described elsewhere.
- B. Jacketing and fitting covers shall be .016 aluminum smooth as manufactured by Premetco or Childers. The jacket shall be pre-cut, pre-rolled, and lapped a minimum of two inches (2") in all directions to shed water. The metal shall be secured at each joint with a minimum of one each (1 ea.) ¾" wide .020 aluminum or stainless steel band and seal. The metal jacketing and fitting covers shall be fabricated of 0.016" aluminum or stainless steel with a smooth finish.

#### 2.06. EXPANSION JOINTS

- A. Where expansion bends occur in the lines, a two foot (2') double layer contraction joint shall be provided in the main line starting two feet from the end of the main line ells on both sides of the expansion loop. Contraction joints shall consist of two 1-1/2" thick x 24" long pipe covering cuts into 17-1/4" and 6" lengths to provide a ¾" space by 10-1/4". A slip joint mastic

(Pittseal III) shall be placed between layers from the  $\frac{3}{4}$ " space provided on the inside layer to the  $\frac{3}{4}$ " space on the outside layer.

- B. The  $\frac{3}{4}$ " space on inside layer shall be filled with mineral wool loose fill and the  $\frac{3}{4}$ " space on the outer layer shall also be filled with same loose fill and joint sealer pressed  $\frac{1}{2}$ " deep into space for sealing (Pittseal III). Around the outside layer at the  $\frac{3}{4}$ " space, there shall be wrapped a 4" wide piece of glass fabric and sealed down with vapor seal mastic. On pipe sizes smaller than aforementioned, the same contraction joint shall be provided using one inch (1") thick "FOAMGLAS" or "KOOLPHEN K" pipe covering for the inner layer. On two inch (2") IPS, both inner and outer layer shall be 1" thick "FOAMGLAS" or "KOOLPHEN K".
- C. The joint and vapor seal mastic shall be Pittsburgh Corning Corporation Pittcote 300. (Note that the asphaltic material specified in this paragraph is intended to be an exception to the flame spread and smoke generation limitations found elsewhere in this specification.
- D. The slip joint sealer shall be Pittsburgh Corning Corporation's Pittseal III.

### PART 3 EXECUTION

#### 3.01 EXAMINATION

- A. Verify that piping has been tested before applying insulation materials.
- B. Verify that surfaces are clean, foreign material removed, and dry.

#### 3.02 INSTALLATION

- A. Install materials in accordance with manufacturer's instructions in the absence of more restrictive requirements or specific instruction herein.
- B. For domestic cold water pipe, seal the ends of fiberglass insulation and provide vapor dams at each end location or every 18', whichever is shorter. Provide vapor dams between pipe and insulation on elastomeric insulation at each section end location or every 20' whichever is shorter.
- C. For cold water pipe, seal the ends of insulation and provide vapor dams at each end location or every 18' whichever is shorter. Provide vapor dams between pipe and insulation on elastomeric insulation at each section end location or every 18' whichever is shorter.
- D. On exposed piping, locate insulation and cover seams in least visible locations, but not higher than at the side of the pipe at the "90°" position, with the seam lapped such that the lap is directed down.
- D. Insulated dual temperature pipes or cold pipes conveying fluids below ambient temperature: Vapor barriers are required. The vapor barrier shall be on the outside. Extreme care shall be taken that the vapor barrier is unbroken. Joints, etc., shall be sealed. Where insulation with a vapor barrier terminates, it shall be sealed off with the vapor barrier being continuous to the surface being insulated. Ends shall not be left raw.
  - 1. Provide vapor barrier jackets, factory applied or field applied. Vapor barrier jacket shall be equal to a Venture Wrap 3.4 mil, "0" perm, cleanable surface vapor jacket with 4" overlap tape strip.
  - 2. Insulate fittings, joints, and valves with molded insulation of like material and thickness as adjacent pipe.

3. Finish with glass cloth and vapor barrier adhesive.
- E. Continue insulation through walls, sleeves, pipe hangers, and other pipe penetrations.
- F. For insulated pipes conveying fluids above ambient temperature:
  1. Provide standard jackets, with or without vapor barrier, factory applied or field applied.
  2. Insulate fittings, joints, and valves with insulation of like material and thickness as adjoining pipe.
- G. If PVC fitting covers are used they shall have 25/50 rating.
- H. For hot piping conveying fluids 140°F or less, do not insulate flanges and unions at equipment, but bevel and seal ends of insulation.
- I. For hot piping conveying fluids over 140°F, insulate flanges and unions, including those at equipment, but label the insulation to indicate a concealed flange or union. See 2.04K.

3.03 INSERTS, SUPPORTS and SHIELDS:

- A. Application: Piping 2 inches diameter or larger for all systems except direct buried.
- B. Shields: Install between pipe hangers or pipe hanger rolls and inserts. Hangers shall be on the outside of the insulation and shall not be in contact with the pipe. Curved metal shields shall be used between the hangers or support points and the bottom of the insulated pipe for Insulated pipes 2" and larger. Curved metal shields shall be designed to limit the bearing stress on the insulation to 35 psi, shall be curved to fit up to mid-perimeter of the insulated pipe and to prevent sharp corners from contacting the jacket. Shields shall be made of galvanized iron, or black iron painted on both sides with two coats of aluminum paint. Required metal shield sizes are as follows:

Nominal IPS	Metal Thickness	Lengths of Shield
up thru 2"	14 gauge	12"
thru 6"	12 gauge	16"
and above	10 gauge	20"

- C. Insert Location: Between support shield and piping and under the finish jacket.
- D. Insert Configuration: Minimum 2" inches longer than length of shield, of same thickness and contour as adjoining insulation; may be factory fabricated.
- E. Insert Material: Heavy density insulating material suitable for the planned temperature range, and the weight of the pipe.
- F. The shields at support points shall be secured with ½" x 0.016" stainless steel bands and seals.
- G. Finish insulation at supports, protrusions, and interruptions.
- H. The application of the protective shields at rack and guide points in tunnels and in central chilling stations shall be as detailed on the accompanying Drawings.

- I. In lieu of the above the following system of support may be used:
  1. At the pipe support positions, the insulation and vapor barrier shall be continuous and shall not be punctured by the support. The insulation at the support shall be the full circumference of 5lbs/ft<sup>3</sup> Phenolic Foam material to withstand the bearing loads transmitted from the pipe to the support, it shall extend for at least 1" on either side of the support to allow sealing of the joints with the pipe insulation jacket.
  2. The load bearing insulation at the support shall be capable of withstanding the maximum static compressive loads generated by pipe supported at the centers shown in Table 1.

Variations: Pipe loads greater than those generated at the support centers shown in Table 1 shall be referred to the manufacturer to establish the length and density of the insulated support block. The support centers are based on the weight of Sch 80 pipe filled with water and covered with 1" thickness of 2.2 lbs/ft<sup>3</sup> standard insulation including FSK/ASJ vapor barrier.

Table 1 K Block Support Centers

Nominal Pipe Size	3/4	1	1 1/4	2	2 1/2	3	4	6	8	10	12	14	16	18	20	24
Max support centers (feet)																
Sch 80 pipe filled with water covered with 1" of Standard Insulation	6.5	6.5	6.5	10	10	10	10	10	14	14	14	20	20	20	20	20
Metal Saddle Gauge (Galvanized Steel)	22	22	22	20	20	20	16	14	14	14	14	14	14	14	14	14
Length of K Block (inches)	6	6	6	6	6	6	6	9	9	9	9	9	9	12	12	12

1. The Insulation at supports shall be a equal to Kooltherm K Block. K Blocks shall be faced with factory applied vapor barrier and fitted with a galvanized steel 180° saddle bonded to the bottom section of the K Block, for all pipe sizes 1 1/2" and larger.
  2. The vapor barrier shall be completed by the use of a vapor barrier jacket 4" overlap and factory applied self-seal lap tape and sealed with vapor barrier adhesive.
  3. At all support positions, other than those where the insulated pipe support block is surrounded by a clip or saddle in direct contact with the block, a block designed to accept the loads generated by the pipe shall be presented to the engineer for approval. e.g. Of the type Kooltherm Insulation products K Block. Ref:- Kooltherm sketch 106/2c for use with Roller or flat beam support.
  4. In all cases where roller supports are used the length of the insulation and the wearing plate where fitted shall extend beyond the limits of the pipe movement.
- C. Where canvas finish is specified, use Arabol lagging adhesive to prevent mildew in securing canvas. Do not use wheat paste. In addition, cover all canvas insulation with a fire retardant coating.
- D. For purpose of definition in this Specification: "concealed" areas are those areas which cannot be seen by the building occupants, and "exposed" areas are all areas which are

exposed to view by the building occupants, including under counter and inside cabinet areas, plus all mechanical rooms.

- E. Self Sealing Lap and butt joints will not be acceptable as the only seal on piping insulation joints. Self Sealing Lap and butt joints may be utilized only if the joints are additionally secured with field applied vapor barrier adhesive (on piping Systems requiring vapor barriers) or staples and field applied adhesive (on piping system which do not require a vapor barrier jacket). Mechanical fasteners shall be used whenever possible to assure permanent installation.
- F. Insulation minimum thickness shall be as scheduled; however, additional thickness shall be provided to prevent condensation on the cold surfaces and to provide a maximum exterior insulation surface of 140°F on the hot surfaces.
- G. Special Protection: All insulated piping in the mechanical rooms within 8'-0" of the floor shall be encased in a protective jacket, and where applicable, finish at top with nickel-plated brass flange plate with set screws or end joint sealing butt strips.
- H. Interior or conditioned areas are those where ambient conditions are typically below 76°F and humidities are below 60% RH. All other areas shall be considered exterior or exposed to outside conditions. Where enclosed and not conditioned but subject to high humidities the insulation shall be designed to prevent condensation at 80°F and humidities are at 90% RH.
- I. All exposed outdoor piping shall have metal jacket.
- J. Fitting insulation shall be applied in same manner as pipe application. Protruding metal parts (such as valve stems) shall be completely sealed off. Fitting cover jacketing shall be equal to Gasco, Pabco or RPR Metals prefabricated fitting covers of 0.016" paper coated aluminum, secured as recommended by the manufacturer.
- K. Valves, fittings, etc., in congested areas around coil and heat exchanger equipment, etc., shall be insulated by building up fitting segments and premolded sections as necessary.
- L. No pipe supporting device (other than guides or anchors attached directly to the pipe) shall penetrate the insulation.

#### 3.04 PAINTING:

- A. All exposed insulation shall be prepared to receive painting specified under Section 09 91 00.
- B. The pipe primer shall be Pittsburgh Corning Corporation Pittcote 300.

**Insulation 'R' Value Schedule (R = thickness / k)**

Service	Oper Temp °F	'k' @ Mean Temp °F	Min. R value for each Pipe Size				
			1" & less	1-1/4" to 2"	2-1/2" to 4"	5" & 6"	8" & over
Hot(1)	350+	.33 @ 250	7.5	7.5	10.0	12.0	13.0
Hot(2)	251-350	.30 @ 200	6.5	8.5	8.5	11.5	12.5
Hot(3)	201-250	.29 @ 150	5.2	5.2	6.9	6.9	12.1
Hot(4)	141-200	.27 @ 125	5.6	5.6	5.6	5.6	5.6
Hot(5)	105-140	.26 @ 100	3.8	3.8	5.8	5.8	5.8
Cold(6)	40-55	.25 @ 75	2.0	3.0	4.0	4.0	4.0
Cold(7)	below 40	.25 @ 75	4.0	6.0	6.0	6.0	6.0

- (1) HTHW; Steam @ over 120#
- (2) HTHW; Steam @ 16# to 120#; med & hp condensate; water and fire line freeze protection
- (3) HTHW; Steam @ 0# to 15#; LP Condensate
- (4) HW
- (5) HW
- (6) Ch. Wtr; Dom. cold wtr; Storm; Cold condensate
- (7) Ch. Wtr; Brine; Refrig lines

Minimum 'R' does not consider water vapor transmission and condensation. Additional insulation and/or vapor retarders may be required to limit water vapor transmission and condensation under extreme conditions.

A minus 15 percent tolerance, on the insulation performance listed shall be permitted for manufacturers' standard insulation systems

No chilled or heating water, steam or condensate insulation shall be less than 2" thickness. No chilled water pipe insulation in unconditioned space shall be less than three inch thickness.

END OF SECTION

SECTION 23 22 00  
STEAM AND STEAM CONDENSATE PIPING

PART 1 GENERAL

1.00 The following sections are to be included as if written herein:

- A. Section 23 00 00 – Basic Mechanical Requirements
- B. Section 23 05 29 – Sleeves, Flashings, Supports and Anchors

1.01 WORK INCLUDED

- A. Pipe and pipe fittings.
- B. Valves.
- C. Steam piping system.
- D. Steam condensate piping system.

1.02 RELATED WORK

- I. Section 23 07 19 - Piping Insulation.
- J. Section 23 22 00.A - Steam and Steam Condensate Specialties.

1.03 REFERENCES

- A. ANSI/ASME SEC 9 - Welding and Brazing Qualifications.
- B. ANSI/ASME B16.3 - Malleable Iron Threaded Fittings Class 150 and 300.
- C. ANSI/ASME B16.23 - Cast Copper Alloy Solder Joint Drainage Fittings - DWV.
- D. ANSI/ASME B16.29 - Wrought Copper and Wrought Copper Alloy Solder Joint Drainage Fittings - DWV.
- E. ANSI/ASME B31.1 - Code for Power Piping.
- F. ANSI/ASME B31.9 - Building Services Piping.
- G. ANSI/AWS A5.8 - Brazing Filler Metal.
- H. ANSI/AWS D1.1 - Structural Welding Code.
- I. ASTM A135 - Pipe, Steel, Black and Hot-Dipped Zinc Coated, Welded and Seamless.
- J. ASTM A234 - Pipe Fittings of Wrought Carbon Steel and Alloy Steel for Moderate and Elevated Temperatures.
- K. ASTM B32 - Solder Metal.
- L. ASTM B88 - Seamless Copper Water Tube.



1.04 REGULATORY REQUIREMENTS

- A. Conform to ANSI/ASME B31.9, and ANSI/ASME B31.1.

1.05 QUALITY ASSURANCE

- A. Valves: Manufacturer's name and pressure rating marked on valve body.
- B. Welding Materials and Procedures: Conform to ANSI/ASME SEC 9, and applicable state labor regulations.
- C. Welders Certification: In accordance with ANSI/AWS D1.1.

1.06 SUBMITTALS

- A. Submit product data under provisions of Section 23 00 00.
- B. Include data on pipe materials, pipe fittings, valves and accessories.
- C. Include welder's certification of compliance with ANSI/AWS D1.1.

1.07 DELIVERY, STORAGE, AND HANDLING

- A. Deliver products to site under provisions of Section 23 00 00.
- B. Store and protect products under provisions of Section 23 00 00.
- C. Deliver and store valves in shipping containers with labeling in place.

PART 2 PRODUCTS

2.01 PIPING AND FITTINGS: (See also Section 23 20 00.A)

- A. Piping systems shall conform to the following requirements.
- B. Piping systems designed for steam pressure below 15 psig are low pressure steam systems. Piping systems designed for steam pressures from 15 psig up to and including 125 psig are medium pressure steam.
- C. Condensate Return and Pumped Condensate Return Piping:
  - 1. All piping shall be Schedule 80 black steel piping.
  - 2. Fittings on piping 2-1/2" and larger shall be extra heavy butt welding type. Flanges shall be 150# welding neck type. Extra strong Weld-O-Lets, Thread-O-Lets, or shaped nipples may be used only when take-off is 1/3 or less nominal size of main.
  - 3. Screwed fittings around traps and for piping 2" and smaller shall be 125# black cast iron. (300# for unions). At contractor's option, socket weld fittings may be used.
- D. Low and Medium Pressure Steam Piping:
  - 1. All piping shall be Schedule 40 black steel piping, except sizes 1" and smaller shall be Schedule 80.

2. Fittings on piping 2-1/2" and larger shall be standard weight butt welding type. Flanges shall be 150# welding neck type. Standard weight Weld-O-Lets, Thread-O-Lets, and shaped nipples may be used only when take-off is 1/3 or less nominal size of main. Bushings shall not be used.
  3. Screwed fittings around traps and for piping 2" and smaller shall be 125 lb. black cast iron. (250 lb. for unions.) At contractor's option, socket weld fittings may be used.
- E. Low and Medium Pressure Clean Untreated Steam (304 Stainless Steel):
1. Pipe 2" and smaller: ASTM A312, TP 304, Schedule 40, stainless steel.
    - a. Fittings: ASTM A182, Gr. F304, ANSI B16.11, 3000 lb. socket-weld.
    - b. Unions: 3000 lb socket-weld, stainless steel ground joint.
  2. Pipe 2-1/2" and larger: ASTM A312, TP 304, Schedule 40, stainless steel.
    - a. Fittings: ASTM A403, Gr. WP304/ANSI 16.9, Butt-weld.
    - b. Unions: None
    - c. Flanges: ASTM A182, Gr. F304, ANSI B16.5, 150 lb. standard with 1/16" raised face, serrated face finish and welding neck.
    - d. Bolts: Stud bolts, ASTM A193, Gr. B7.
    - e. Nuts: ASTM A194, Gr. 2H.
- F. Weld Fittings, Flanges and Unions:
1. Refer to Section 23 20 00.A.
- G. Piping Materials:
1. Sizes shown on the Drawings are nominal pipe sizes unless otherwise indicated.

## 2.02 VALVES:

- A. See Section 23 20 00.A.

## 2.03 STRAINERS:

- A. See Section 23 06 20.

## 2.04 UNIONS:

- A. See Section 23 20 00.A.

## PART 3 EXECUTION

### 3.01 PREPARATION

- A. Ream pipe and tube ends. Remove burrs. Bevel plain end ferrous pipe.
- B. Remove scale and dirt on inside and outside before assembly.
- C. Prepare piping connections to equipment with flanges or unions.
- D. After completion, fill, clean, and treat systems.

### 3.02 INSTALLATION

- A. Route piping in orderly manner, plumb and parallel to building structure, and maintain gradient.
- B. Install piping to conserve building space and not interfere with use of space, other work, or equipment.
- C. Install piping to allow for expansion and contraction without stressing pipe, joints, or connected equipment. Refer to Section 23 05 16.
- D. Provide clearance for installation of insulation and access to valves and fittings.
- E. Provide access where valves and fittings are not exposed. Coordinate size and location of access doors with the General Contractor.
- F. Slope steam piping one inch in 40 feet (0.25 percent) in direction of flow. Use eccentric reducers to maintain bottom of pipe level.
- G. Slope steam condensate piping one inch in 40 feet (0.25 percent). Provide drip trap assembly at low points and before control valves. Run condensate lines from trap to nearest condensate receiver. Provide loop vents over trapped sections.
- H. Where pipe support members are welded to structural building framing, scrape, brush clean, and apply one coat of zinc rich primer to welding.
- I. Prepare pipe, fittings, supports, and accessories for finish painting. Refer to Section 09 91 00.
- J. Install valves with stems upright or horizontal, not inverted.

### 3.03 APPLICATION

- A. Install unions downstream of valves and at equipment or apparatus connections. Install dielectric unions where joining dissimilar materials.
- B. Install brass male adapters each side of valves in copper piped system. Sweat solder adapters to pipe.
- C. Install valves for shut-off and to isolate equipment, part of systems, or vertical risers.
- D. Install valves for throttling, bypass, or manual flow control services.
- E. All high pressure steam valves 12" and larger shall be piped with an equalizing bypass valve assembly.

### 3.04 CLEANING AND FLUSHING OF STEAM SYSTEMS:

- A. Steam and condensate systems shall be thoroughly cleaned before placing in operation to rid systems of rust, dirt, piping compound, mill scale, oil, grease, any and all other material foreign to water being circulated.
- B. Extreme care shall be exercised during construction to prevent dirt and other foreign matter from entering the pipe or other parts of systems. Pipe stored on the project shall have open ends capped and equipment shall have openings fully protected. Before erection, each piece of pipe, fitting, or valve shall be visually examined and dirt removed.

- C. Chemicals, feeding devices, and water technician services shall be furnished by a single reputable manufacturer who will be responsible for the complete cleaning and flushing of the systems.
  - 1. Add a temporary line with drain and isolate the building steam and condensate piping from the campus distribution piping to allow for proper circulation and cleaning of the new piping in the new tunnel and/or in the new or modified building piping system(s).
- D. Systems shall be cleaned with a chemical compound specifically formulated for the purposes of removing the above listed foreign matter. These chemicals shall be injected to the systems, circulated and completely flushed out. Repeat the process if required. After each flushing, remove and thoroughly clean all strainers.
- E. Final connection is not to be made to the campus loop system until the Chemical Contractor has filed with the Owner's representatives, a report stating that the systems are clean.
- F. Clean Steam piping shall be flushed with RO water.

3.05 PIPE PRESSURE TESTS:

- A. See Section 23 00 00.

END OF SECTION

SECTION 23 22 00.A.  
STEAM AND STEAM CONDENSATE SPECIALTIES

PART 1 GENERAL

1.00 The following sections are to be included as if written herein:

- A. Section 23 00 00 – Basic Mechanical Requirements
- B. Section 23 05 29 – Sleeves, Flashings, Supports and Anchors
- C. Section 23 05 53 – Mechanical Identification

1.01 WORK INCLUDED

- A. Steam traps.
- B. Steam pressure reducing valves.
- C. Steam relief valves.
- D. Steam safety valve discharge elbows.
- E. Steam pipe guides.
- F. Drip traps.
- J. Sediment strainers.
- H. Gauges and gauge connections.
- I. Thermometer and thermometer wells.

1.02 RELATED WORK

- B. Section 23 05 13 - Motors.
- C. Section 23 07 19 - Piping Insulation.
- D. Section 23 07 16 - Equipment Insulation.
- E. Section 23 06 20 - Hydronic Specialties
- F. Section 23 22 00 - Steam and Steam Condensate Piping.

1.03 REFERENCES

- A. ANSI/ASTM - Boilers and Pressure Vessels Code.
- B. ASTM A105 - Forgings, Carbon Steel, for Piping Components.
- C. ASTM A126 - Gray Iron Castings for Valves, Flanges, and Pipe Fittings.
- D. ASTM A216 - Steel Casings, Carbon, Suitable for Fusion Welding, for High Temperature Service.

E. ASTM A395 - Ferric Ductile Iron Pressure-Retaining Castings for Use at Elevated Temperatures.

F. ASME B31.9 - Building Services Piping.

#### 1.04 REGULATORY REQUIREMENTS

A. Conform to ASME B31.9 - Building Services Piping.

#### 1.05 QUALITY ASSURANCE

A. Manufacturer: For each product specified, provide components by same manufacturer throughout.

#### 1.06 SUBMITTALS

A. Submit shop drawings and product data under provisions of Section 01 33 00 and 01 33 23.

B. Submit shop drawings and product data for manufactured products and assemblies required for this project.

C. Include product description, model, dimensions, component sizes, rough-in requirements, service sizes, and finishes.

D. Submit schedule indicating manufacturer, model number, size, location, rated capacity, and features for each specialty.

E. Submit manufacturer's installation instructions under provisions of Section 01 33 00 and 01 33 23.

#### 1.07 OPERATION AND MAINTENANCE DATA

A. Submit operation and maintenance data under provisions of Section 01 77 00 and 01 78 23.

#### 1.08 EXTRA STOCK

A. Provide two service kits for each size and type of steam trap under provisions of Section 01 77 00.

### PART 2 PRODUCTS

#### 2.01 ACCEPTABLE MANUFACTURERS - STEAM TRAPS

A. Armstrong

B. Spirax/Sarco

C. Shipco.

D. Substitutions: Under provisions of Section 23 00 00.

## 2.02 INVERTED BUCKET TRAPS

- A. Cast iron or semi-steel body and bolted cover for 250 psig WSP; provide access to internal parts without disturbing piping; with top test plug and bottom drain plugs, brass or stainless steel bucket, stainless steel seats and plungers, and stainless steel lever mechanism with knife edge operating surfaces, integral inlet strainer of monel or stainless steel.

## 2.03 FLOAT AND THERMOSTATIC TRAPS

- A. ASTM A126, cast iron or semi-steel body and bolted cover for 250 psig WSP; provide access to internal parts without disturbing piping; with bottom drain plug, stainless steel or bronze bellows type air vent, stainless steel or copper float, stainless steel lever and valve assembly.

## 2.04 THERMOSTATIC TRAPS

- A. Pressure balanced type with ASTM A216 WCB cast steel body and bolted or screwed cover, and integral ball joint union, for 300 psig WSP; monel or stainless steel bellows, stainless steel valve and seat; integral stainless steel strainer.
- B. Freeze proof type with cast iron body for 300 psig WSP, bronze bellows, stainless steel valve and seat, external adjustment.
- C. Bi-metallic type with ASTM A105 forged steel body and cover, for 300 psig WSP, bi-metal element with stainless steel components, integral Type 304 stainless steel strainer screen, 1/4 inch blow down valve.
- D. Clean steam thermostatic traps for non-critical process areas shall be self-adjusting balanced pressure type capable of operating close to saturated steam temperature. All wetted parts shall be manufactured from 316L stainless steel. Traps shall be maintainable or of sealed construction and shall be completely self draining when installed in a vertical pipeline.

## 2.05 CLEAN STEAM VALVES

- A. Gate Valves.
  - 1. Socket-welded Pipe: Stainless steel body, flanged, stainless steel solid wedge, stellite seats, rising stem, union bonnet, malleable iron handwheel impregnated Teflon packing, Class 150 (150 psi WP steam), Williams Figure S15F6-316.
  - 2. Welded Pipe: Stainless steel body, flanged, stainless steel solid wedge, stellite seats, impregnated teflon packing, Class 150 (150 psi WP steam), equal to Williams Figure S15F6-316
  - 3. Drain valves: Use gate valve as specified above with hose thread adapter. Provide 3/4" minimum drain valve size except strainer blowdown valves to be blowdown connection size.
- B. Globe Valves.
  - 1. Socket-welded Pipe: Stainless steel body, flanged, stainless steel disc, stellite seats, impregnated teflon packing, union or screw-over bonnet, malleable iron handwheel Class 150 (150 psi WP steam), Williams Figure S152F6-316.
  - 2. Welded Pipe: Stainless steel body, flanged, stainless steel disc, stellite seats, Class 150, (150 psi WP steam), Williams Figure S152F6-316 approved equivalent model by listed manufacturers.

- C. Check Valves
  - 1. Socket-welded Pipe: Stainless steel body, flanged, stainless steel disc, Class 150 (150 psi WP steam), Williams, Powell or Velan equal to Williams Figure S151F6-316.
  - 2. Welded Pipe: Stainless steel body, flanged, stainless steel disc, Class 150 (150 psi WP steam), Williams Figure S151F6-316.

#### 2.06 STEAM PRESSURE REDUCING VALVES:

- A. All pressure reducing valves shall be capable of maintaining the set pressure from zero to the maximum steam flow within reasonable limits when subjected to usual steam pressure fluctuations. They shall be single seated valves with stainless steel trim, with renewable valve, lugs and seats. Valve bodies shall be cast steel for high pressure service and cast iron for medium and low pressure service. These valves shall be self contained type with upstream and downstream pressure gauges and shall be installed as per manufacturer's recommendations. Valve capacities are scheduled on the drawings. Pressure reduction is one stage (50 to 15 psig). Station shall consist of two PRV's, each sized for 100% capacity. Discharge pressure shall be adjustable to any value between 15 psig and 75% of the supply pressure. Refer to detail 1 on sheet P-202 for more information.
- B. All pressure regulators 2-1/2" and larger shall have flanged connections and those 2" and smaller may have screwed connections. Unions shall be installed on each side of any screwed pattern regulators installed.
- C. Each reducing valve shall be preceded by a sediment strainer complete with a full-sized blow off valve with threaded end for hose connection.
- D. These valves shall be Leslie, Spence (delete Spence on Austin projects, list first on Galveston projects), Spirax Sarco, Fisher, Mason Neilan or approved equal, with suitable automatic controllers.

#### 2.07 STEAM RELIEF VALVES:

- A. Relief valves 2" and smaller shall have brass bodies and arranged for screwed connections. Such relief valves shall be Crane No. 2501 or Spirax Sarco 6010 Brass Safety Valves for steam or approved equal. Bushings shall not be used.
- B. Relief valves 2-1/2" and larger shall in the case of all medium and low pressure steam piping systems be arranged for flanged inlet and screwed outlet connections. Such relief valves shall be Consolidated Type 1511 or Spirax Sarco 252, ASME Standard Cast Iron Safety Valves, or approved equal.
- C. The pressure at which each relief valve shall open is designated on the Drawings. When such valves are ordered by the Contractor, he shall definitely specify the pressure at which each relief valve is to be set. Each valve shall have a metal tag attached stamped with the valve identification plus the pressure setting.

#### 2.08 STEAM SAFETY VALVE DISCHARGE ELBOWS:

- A. All vent lines from safety valves shall be provided with safety valve discharge elbows at the point at which such lines rise to an elevation higher than that of the safety valve. The nature and design of the piping systems involved shall be such as to drain effectively all condensate from the discharge side of all relief valves. These safety valve discharge elbows shall be Grinnell Company's Safety Valve Drip Pan Elbows Figure No. 1538F, Spirax Sarco No. 299, or approved equal. No force shall be exerted on the safety valve by the discharge piping.



2.09 STEAM PIPE GUIDES:

- A. All steam piping systems shall be properly guided as shown on the Drawings.

2.10 DRIP TRAPS:

- A. High pressure drip trap assemblies shall be provided wherever called for on the Drawings and where required to keep such piping systems completely drained of condensate. Traps used in assemblies shall be 3/4" traps unless specifically shown to the contrary, i.e., they shall have 3/4" inlet and outlet connections. They shall have semi-steel bodies and the internal operating mechanisms shall be made of heat treated chrome steel. The caps shall be bolted to the bodies by the use of alloy steel heat treated machine bolts. These No. 213 Armstrong Traps, manufactured by Armstrong Machine Works, or approved equal, shall have a capacity for discharging at least 3,500 pounds of condensate per hour when operating at a pressure of 250 pounds per square inch. Where drip traps are installed in conjunction with 3" and larger steam lines, a drip pocket of the nature detailed on the Drawings shall be provided where a natural pocket does not exist. The piping and valves in trap assemblies shall be arranged as detailed on the Drawings; extra strong pipes shall be used on both sides of the trap.
- B. All drip traps used in medium pressure steam piping systems where automatic steam control valves are not employed shall be arranged as shown on the Drawings. They shall be 3/4" Armstrong No. 811 Inverted Bucket Traps, or approved equal, with cast iron bodies, vacuum breakers and stainless steel trim. Each trap shall be provided with a valved test line and shall be preceded by a sediment strainer.
- C. Condensate from coils, converters, hot water generators, low pressure drips and from all other devices where modulating steam valves are employed shall be of the float and thermostatic type. These traps shall be sized to handle 200% of the load with an inlet pressure drop of 0.5 psig and shall be equal to Armstrong "A" or "B" series, with vacuum breaker suitable for the system pressures. Installed traps with less than 12" of height between equipment outlet and trap inlet shall be sized for not less than 300 percent of the load. Each trap shall be provided with a 1/2" valve test line and shall be preceded by a sediment strainer. Under no circumstances shall a float and thermostatic trap be installed in a manner to lift condensate up in a return line.
- D. Shop Drawing submittal of traps shall contain an itemized list with a tabulation of the load, trap type, and trap size.

2.11 SEDIMENT STRAINERS:

- A. Each drip trap assembly, each control valve, for steam and each pressure reducing valve assembly regardless of its size shall be preceded by a sediment strainer. The arrangement of these sediment strainers shall be such that the screens may be removed for cleaning with ease through a gasketed plug.
- B. Sediment strainers shall be placed in steam piping systems wherever shown on the Drawings and at such other points as may be required for the removal of foreign material from the piping systems.
- C. Strainers in high pressure steam piping shall be cast steel sediment strainers and shall be suitable for working steam pressures as high as 300 pounds per square inch and temperatures not in excess of 750 degrees F. These strainers shall be the size designated on the Drawings. In the case of pipe sizes 2-1/2" and larger, flanged pattern sediment

strainers shall be used. In the case of pipe smaller than 2-1/2", screwed pattern shall be used. Such strainers shall be Yarway No. 821 or 822 strainers manufactured by Yarnall Waring Company, or approved equal. The flanges of flanged strainers shall be dimensioned, faced, drilled, and spot faced to conform to the 300 pound American Standard for Steel Pipe Flanges and Flanged Fittings (B16e-1939).

- D. Strainers in low and medium pressure steam piping systems 2-1/2" and larger shall be flanged iron body strainers having bolted covers. These strainers shall be suitable for operating pressures as high as 125 psig. They shall be Crane Company No. 989-1/2 Sediment Separators, or approved equal.
- E. Sediment strainers in low and medium pressure steam piping systems 2" and smaller shall be arranged for screwed pipe connections. They shall be Crane No. 988-1/2 Sediment Separators, or approved equal.
- F. Full sized blow off valves shall be installed on all strainers in steam, condensate, chilled and hot water lines and a drain shall be installed from each valve to the nearest floor drain.

#### 2.12 GAUGES AND GAUGE CONNECTIONS:

- A. See Section 23 05 19.
- B. Furnish and install, where noted or indicated on the accompanying Drawings or called for elsewhere in these Specifications, gauge connections complete with Ashcroft No. 1095 lever handle union shutoff cocks, or approved equal. All gauge connections shall be made up with brass pipe, nipples and brass screw fittings.

#### 2.13 THERMOMETER AND THERMOMETER WELLS:

- A. See Section 23 21 00.A.
- B. Thermometer wells and thermometers shall be located where noted on the accompanying Drawings and where called for in other sections of the Specifications. Thermometer test wells only shall be installed in a vertical position in horizontal lines and at 45 degrees, in vertical lines to hold a fluid in the well.

### PART 3 EXECUTION

#### 3.01 INSTALLATION AND APPLICATION

- A. Install specialties in accordance with manufacturer's instructions.
- B. Install thermostatic steam traps to drain condensate from steam radiation units, convectors, and other similar terminal heating units.
- C. Install float and thermostatic traps to drain condensate from unit heaters, converters, heating coils, steam separators, flash tanks, steam jacketed equipment, and direct steam injected equipment.
- D. Install inverted bucket steam traps to drain condensate from steam main headers and branch lines.
- E. Size steam traps to handle minimum of two times maximum condensate load of apparatus served.

- F. Traps used on steam mains and branches shall be minimum 3/4 inch (20 mm) size.
- G. Install steam traps with union or flanged connections at both ends.
- H. Provide gate valve and strainer at inlet, and gate valve [and check valve] at discharge of steam traps.
- I. Provide minimum 10 inch (250 mm) long dirt pocket of same pipe sizes as apparatus return connection between apparatus and steam trap.
- J. Remove thermostatic elements from steam traps during temporary and trial usage, and until system has been operated and dirt pockets cleaned of sediment and scale.
- K. Provide pressure reducing stations with pressure reducing valve, valved bypass, strainer and pressure gage on upstream side, relief valve and pressure gage on downstream side of pressure reducing valve.
- L. Pressure reducing station shall be one or two stages as indicated, to produce flat reduced pressure curve over range of capacity.
- M. Rate relief valves for pressure upstream of pressure reducing station, for full operating capacity. Set relief at maximum 20 percent above reduced pressure.
- N. Terminate relief valves to outdoors. Provide drip pan elbow with drain connection to nearest floor drain.
- O. When several relief valve vents are connected to a common header, header cross section area shall equal sum of individual vent outlet areas.

END OF SECTION

DIVISION 26 00 00 - ELECTRICAL

1. GENERAL

- A. Furnish all labor, supervision, materials, equipment, apparatus and appurtenances required for a complete working and coordinated electrical system as shown on the drawings and specified herein.
- B. Wherever applicable or not otherwise specified, all electrical work including equipment, material and installation shall be in accordance with base building specifications and practices.
- C. All electrical work shall be constructed and finished in every respect in a workmanlike and substantial manner. Furnish and install all work necessary to complete the system in accordance with the best trade practice and to the satisfaction of the engineer. The entire installation shall be ready in every respect for satisfactory and efficient operation when completed. The engineer will interpret the meaning of the drawings and specifications and may reject any work and materials which, in their judgment, is not in full accordance therewith.
- D. Submit a single certification stating that all portions of the work are in accordance with contract requirements. Warranty all work against faulty and improper material and workmanship for a period of one year from date of final acceptance by the tenant, except that where guarantees or warranties for longer terms are specified, such longer term shall apply. At no additional cost to tenant or engineer, within 24 hours after notification, correct any deficiencies which occur during the warranty period, to the satisfaction of the tenant.
- E. The contractor covenants and agrees that he and his subcontractors and his and their agents and employees will provide and maintain a safe place to work and will comply with all laws and regulations of all governmental authorities having jurisdiction thereof, and the contractor agrees to indemnify, defend and hold harmless, the engineer and tenant from and against any liability, loss, damage or expense, including attorneys' fees, arising from a failure or alleged failure on the part of the contractor, his subcontractors and his and their agents and employees to provide and maintain a safe place to work or to comply with laws and regulations of governmental authorities having jurisdiction thereof.
- F. The contractor and each subcontractor covenants and agrees to indemnify, defend and hold harmless the Engineer and tenant against any liability, loss, damage or expenses, including attorneys' fees, arising from a failure or alleged failure on the part of the contractor, his subcontractor or his or their agents and employees to properly discharge the obligations assumed by him or them in the performance of the work, including any act or omission allegedly resulting in death or personal injury or property damage on improper construction, construction techniques, or the use of improper or inappropriate material or tools.
- G. The drawings show various conduit and wiring systems schematically and provide circuit numbers for reference only. Provide additional neutral wire where it is necessary to run circuits of the same phase in common conduit (maximum of three phase conductors in a single conduit). Balance all panelboards and record all circuit numbers on as-built drawings.
- H. Comply with all applicable requirements of the building owner, the tenant lease and building design criteria for tenant improvements.
- I. Architectural specifications and general, special and supplementary conditions, where provided, shall form a part of these specifications.

2. CODES AND PERMITS

- A. All work shall be done in full compliance with the National Electrical Code, all applicable state and local codes, requirements and ordinances and applicable requirements of NFPA, UL and other applicable standards.

- B. All equipment and materials shall be new and listed by the Underwriters' Laboratories, Inc., Manufactured in full accordance with applicable ASME, NEMA, ANSI, or IEEE standards.
- C. Secure and pay for all necessary approvals, permits, inspections, etc., and deliver the official records of the granting of such to the tenant without additional cost to the tenant.

3. COORDINATION

- A. Coordinate the work of this section with the work of other sections in ample time for the proper installation and connection. Carefully check space requirements with other trades to ensure that all equipment and materials can be installed in the spaces allotted thereto.
- B. Carefully check the documents of other Divisions to ascertain the requirements of any materials or equipment being furnished or furnished and installed by that Division and provide the proper installation and connections including any control wiring required.
- C. Transmit all information required for work being performed by other trades in ample time for the proper installation and connection and for the provision of all openings required in floors and walls.
- D. Refer to architectural drawings for exact locations of all lighting fixtures, outlets and switches, including mounting heights. Refer to the architectural drawings for finishes of equipment and materials not specified herein.
- E. All interruptions of services (power, fire alarm, water, HVAC, etc.) and all work in occupied tenant spaces (e.g. plumbing or electrical work in an occupied tenant's space below a space under construction) must be scheduled through the building manager a minimum of 24 hours in advance. Any interruptions or construction which will affect normal operation of the building or it's tenants shall be scheduled, with the building manager's approval, on an after-hours basis.
- F. Field core drilling and cutting of holes in the existing structure for the work under this section shall be the responsibility of this contractor. Drilling and cutting shall be coordinated through the general contractor and approved by the building manager. Where the services of a structural engineer are necessary to approve such drilling and cutting, this contractor shall bear the cost of such services. All costs for drilling, cutting, and associated structural reinforcing shall be borne by this contractor.
- G. Cutting and patching of new and existing building finishes for installation of work of this section shall be coordinated through the general contractor and approved by the building manager. Where cutting and patching is approved, it shall be performed by the trades who normally install the work which is being removed and the cost of cutting and patching shall be borne by this contractor.

4. EXISTING CONDITIONS

- A. Before submitting a bid, the contractor shall become thoroughly familiar with actual existing conditions at the building and the present installations to which connections must be made or which must be changed or altered. The intent of the work is shown on the drawings and described herein, and no consideration will be granted by reason of lack of familiarity on the part of the contractor with actual physical conditions at the site.
- B. Schedule all work connecting with existing systems to ensure a minimum of service interruption. Notify the building manager in writing of any planned interruption in service in ample time for the building manager's convenience and proceed with plan only after the building owner's written approval is obtained.
- C. Where specifically called for on the drawings or when permission is specifically given by the tenant or building manager, existing equipment and material may be reused.
- D. Verify and become thoroughly familiar with building systems, such as life safety and emergency lighting and provide for the proper wiring and interconnects where applicable.

- E. This contractor shall repair any fireproofing damaged by this contractor, to the integrity of the original construction.
- F. This Contractor shall include relocation of 30 lineal feet of 3/4" conduit and three junction boxes to allow proper installation of the Mechanical and Plumbing systems.

5. DEMOLITION

- A. Refer to Architectural Demolition and Renovation Plans for scope of area being renovated and walls to be removed.
- B. Where electrical devices occur in walls being removed, the electrical contractor is responsible for removing all wire and conduit back to a junction to remain, to the homerun junction box or flush with chase walls, floor penetrations or areas where access to the conduit is restricted. Where the circuit is released the electrical contractor shall remove the wire from the breaker and turn the breaker to the "off" position.
- C. Where electrical devices are removed, it is the responsibility of the electrical contractor to ensure circuit continuity to remaining electrical devices, that are not in areas where the demolition is occurring.

6. SUBMITTALS

- A. Prepare and submit detailed shop drawings for electrical equipment as requested herein. Equipment installed without approval thereof shall be done at the risk of this contractor and the cost of removal of such equipment or related work which is judged unsatisfactory for any reason shall be at the expense of this contractor.
- B. During the progress of the work, make a careful record of all instances where the actual installation differs from that indicated on the contract drawings. Where branch circuit conduit connections between individual devices are not shown on the contract documents, as-built drawings shall show the branch circuit connections between devices as actually installed. Upon completion of the installation, furnish two complete sets of reproducible as-built drawings. These drawings shall be submitted to the engineer for approval. After approval they shall become the property of the tenant and building owner. Final payment will be withheld until receipt of the approved as-built drawings.
- C. Submittal reviews for equipment will not be made upon submission of manufacturers' names. Submittal reviews for equipment will be made only after receipt of complete and satisfactory submittals. Equipment will be reviewed for general compliance with the design concepts shown on the Construction Documents. The opinion and judgment of the Engineer shall be final.
- D. Notify the engineer, in writing, within 5 days of award of contract, of the proposed delivery schedule for any equipment or material which will prevent the installation from being completed at the time of the scheduled project completion.
- E. Submit manufacturer's data or shop drawings of the following apparatus, as applicable, giving full information as to dimensions, materials, features, performance data and other information pertinent to the submitted equipment.
  - Light fixtures and lamps
  - Wiring devices
  - Electrical equipment

7. TESTING

- A. The contractor shall fully test all systems, which the contractor has installed, for proper operation and shall demonstrate such proper operation to the tenant and engineer's representative.
- B. Prior to energization, all new feeder and branch circuit conductors shall be checked for continuity and short circuits.

- C. All new feeder conductors shall have their insulation resistance tested after its installation is complete except for connection at the source and point of termination. Tests shall be made using a Biddler Megger or equivalent test instrument at a voltage of not less than 1,000 volts dc, and after one minute of operation at slip speed. Resistance shall be measured from conductor to conductor and conductor to ground for all installed conductors. Conductors which do not meet or exceed the following insulation resistance values shall be removed, replaced and retested:

<u>WIRE SIZE (AWG)</u>	<u>INSULATION RESISTANCE (OHMS)</u>
No. 12	1,000 K
No. 10 and No. 8	250 K
No. 6 through No. 2	100 K
No. 1 through No. 4/0	50 K
250 MCM and larger	25 K

#### 8. LIGHTING FIXTURES AND LAMPS

- A. Furnish and install light fixtures and lamps as specified on the drawings. Light fixtures shall be complete with all required accessories for proper installation in the ceiling types in which they are installed.
- B. All indoor fluorescent fixture ballasts shall be Advance Mark V energy saving ballasts, unless noted otherwise. All fluorescent lamps shall be Phillips F32T8/TL841/ALTO or an approved equal, unless noted otherwise.
- C. All lighting fixtures and lamps shall be furnished by the electrical contractor, unless noted otherwise on the drawings as reused or relocated existing building standard fixtures furnished by the building owner; or fixtures furnished by the tenant.
- D. Lighting fixtures which are noted to be relocated or reused shall be cleaned and relamped prior to reuse. Fixtures that are damaged or defective shall not be reused, notify Engineer in writing of quantity of fixtures to be replaced. Existing light fixtures which are removed and not reused shall be stored as directed by the building manager.
- E. Conductors for connection to individual light fixtures in grid type ceilings from their associated junction boxes shall be No. 14 AWG THHN, 600 volt, solid copper conductors in 72" long 3/8" flexible metal conduit fixture tails, or by Type MC cable fixture tails where permitted by the local authority having jurisdiction, in lengths not to exceed 10'.
- F. All lay-in lighting fixtures shall be connected to a branch circuit junction box with a flexible fixture tail. A maximum of four fixture tails shall be connected to a single junction box. Fixture to fixture wiring of lay-in fixtures is not permitted.
- G. Provide a minimum of two hold-down clips per fixture, located at opposite corners of fixtures.

#### 9. WIRE AND CABLE

- A. Control wiring shall be stranded copper, No. 14 AWG minimum with Type THW or THHN/THWN insulation. Power wiring sized No. 12 AWG shall be solid or stranded copper with Type THHN/THWN insulation. Power wiring sized No. 10 AWG and larger shall be stranded copper with Type THHN/THWN insulation. Stranded wire shall not be terminated under screw terminals.
- B. Conductor splices, taps, and terminations shall be made using connectors or lugs approved for the intended use. Preinsulated spring connectors may be used for connections and splices of wire sizes up to No. 8 AWG.

- C. All power wiring shall be color coded to match the base building color coding schedule. Color coding shall be via color coded insulation or color coded tape at every conductor splice, termination or tap.
- D. Branch circuits homeruns shall be limited to three phase conductors, on different phases, with neutral and ground conductors as shown and shall be installed in conduit. Separate neutral conductors shall be provided for each phase on data circuits and elsewhere where shown or noted on the drawings, where scheduled or specified.
- E. Type MC cable may be used, where approved by the local authority having jurisdiction: for drops in partitions to receptacles; for single circuit branch circuit wiring from receptacle to receptacle; for lay-in fixture pigtails; for switch leg drops; from fixture junction boxes or nonlay-in fixtures; or for single circuit branch circuit wiring from fixture to fixture (except lay-in fixtures) and fixture to junction box. Type MC cable shall be copper conductors with THHN insulation and a full size green THHN insulated ground wire and an aluminum or galvanized steel flexible armor.
- F. Type MC cable shall not be used for branch circuit homeruns or for receptacle to receptacle wiring in partitions. Type MC cable shall not be used where more than three conductors (phase/neutral/ground) are required, where exposed, or in lengths exceeding 20'.
- G. Type MC cable shall be supported in accordance with the NEC.
- H. For 120 volt, 20 amp branch circuits with a length of 75' or more to the homerun junction box or first outlet, provide minimum No. 10 AWG conductors to the homerun junction box or first outlet. Where the additional circuit length from the homerun junction box or first outlet to the last outlet exceeds 75', provide minimum No. 10 AWG conductors to the last outlet. For 208 volt, 20 amp branch circuits with a length of 100' or more, provide No. 10 AWG conductors for the entire branch circuit. For 208 volt, 30 amp branch circuits with a length of 100' or more, provide No. 8 AWG conductors for the entire branch circuit. For 277 volt, 20 amp branch circuits with a length of 150' or more, to the first outlet provide No. 10 AWG conductors to the center of the load (minimum first outlet, where there is only one outlet).
- I. Conductors for lighting and power branch circuits shall be of such a size that the drop in potential from the panelboards to the farthest point on the circuits shall not exceed 2% at maximum load and 70% power factor, at 120/208 volts and 1% at maximum load at 277/480 volts.

#### 10. CONDUIT AND BOXES

- A. All power wiring shall be installed in an approved raceway, except where Type MC cable is allowed, as specified hereinabove. All control wiring shall be installed in an approved raceway, except that low voltage control wiring may be installed without a raceway, in concealed accessible locations, when a UL-listed plenum rated cable is used. Conduit shall be concealed to the maximum extent possible and when exposed, shall be run parallel and perpendicular to building lines. All conduit and Type MC cable shall be independently supported from the building structure. Supports shall be independent from the ceiling system supports.
- B. Electrical metallic tubing (EMT) shall be used for branch circuit raceways indoors where concealed or exposed. Electrical metallic tubing may not be used in damp or wet locations or where subject to physical damage, and for any emergency or power feeders.
- C. Rigid Steel and Intermediate Metal Conduit: Use rigid steel or intermediate metal conduit to run all electrical raceway systems where exposed to weather; in damp or wet locations; where subject to physical damage; and where cast in concrete walls or floor slabs which have waterproof membranes and where cast in masonry walls. Use rigid steel conduit for all 5/15 kV and 600 volt power feeders and all emergency branch and power feeders, unless otherwise noted. Use rigid steel or IMC conduit for all exposed conduit below 8'-0" above finished floor. IMC conduit shall not be used in sizes larger than 4". Use threaded type couplings and fittings. Split type couplings and fittings are not acceptable.



- D. PVC-coated Rigid Steel: Use polyvinyl chloride (PVC) externally-coated rigid steel conduit and fittings for electrical raceway systems for branch circuits to wet areas; where exposed outdoors; and elsewhere, as shown. Conduit and fittings shall be installed such that the PVC-coating is continuous and watertight such that no portion of the metal conduit or fittings is exposed to moisture.
- E. Flexible conduit, in lengths not to exceed 48", shall be used to extend conduit connections to motors, transformers and other permanently connected appliances, equipment or devices which are vibration producing or require access for maintenance or adjustment. Liquid tight flexible metal conduit shall be used for all flexible connections in damp or wet areas.
- F. PVC conduit shall not be used.
- G. Minimum conduit size shall be 3/4" for power wiring and 3/4" for voice and data, unless noted otherwise on the drawings.
- H. Outlet and junction boxes shall be minimum 4" square or octagonal by 2-1/8" deep with coverplates or plaster rings as required. Larger boxes shall be provided where required by the NEC. Deep boxes shall be provided for all outlet and junction boxes used in suspended ceiling spaces.
- I. All slab penetrations shall be sealed with a UL-listed fire safing and waterstop system and all rated partition penetrations shall be sealed with a UL-listed fire safing system, in accordance with applicable state and local requirements.

11. WIRING DEVICES

- A. Duplex receptacles shall be Decora face, specification grade type and shall match the base building standards, where applicable. Typical receptacle types shall be as follows, or an approved equal:

Office/Lab/General Use

Simplex, NEMA 5-20R, white	_____	Leviton 16351-W
Duplex, NEMA 5-15R, white	_____	Leviton 16252-W
Duplex, NEMA 5-20R, white	_____	Leviton 16352-W
Duplex, NEMA 5-20R, data processing, gray	_____	Leviton 16352-GY
Duplex, NEMA 5-20R, data processing, isolated ground, gray	_____	Leviton 16362-IGG
Duplex NEMA 5-20R, TVSS, isolated ground, audible/visual indicator, white	_____	Leviton 8380-IGW
Duplex, NEMA 5-20R GFCI, white	_____	Leviton #6899-W

- B. Duplex receptacles shall be specification grade type and shall match the base building standards, where applicable. Typical receptacle types shall be as follows, or an approved equal:

Wet Areas

Simplex, NEMA 5-20R, white	_____	Leviton 5361-W
Duplex, NEMA 5-15R, white	_____	Leviton 5262-W
Duplex, NEMA 5-20R, white	_____	Leviton 5362-W
Duplex, NEMA 14-30R, white	_____	Leviton 278
Duplex, NEMA 6-30R, white	_____	Leviton 5372

- C. Where only one wiring device is installed on a 20 ampere branch circuit, then a 20 ampere wiring device must be used.

- D. Switches shall be rocker type, Decora face, specification grade type, rated at 120/277 volts, 20 amps, and shall match the base building standards, where applicable. Typical switch types shall be as follows, or an approved equal:

Office/Lab/General Use

Single pole, white _____	Leviton 5621-2W
Two pole, white _____	Leviton 5622-2W
Three-way, white _____	Leviton 5623-2W
Four way, white _____	Leviton 5624-2W
Single pole, white, pilot light _____	Leviton 5658-2W
Momentary, white _____	Leviton 5657-2W

- E. Switches shall be specification grade type, rated at 120/277 volts, 20 amps, and shall match the base building standards, where applicable. Typical switch types shall be as follows, or an approved equal:

Wet Areas

Single pole, white _____	Leviton 1221-2W
Two pole, white _____	Leviton 1222-2W
Three-way, white _____	Leviton 1223-2W
Four way, white _____	Leviton 1224-2W
Single pole, white, pilot light _____	Leviton 1221-PLC
Momentary, white _____	Leviton 1257-W

- F. Wall box dimmers with linear slide and positive on/off switch, dimmers shall be Lightolier Sunrise series, Prescolite Horizon dimmers maximum 1000 watts or an approved equal. Matching switches shall be provided where noted on the drawings. Wall box dimmers shall be white, unless noted otherwise. Ganged dimmers and switches shall be provided with a common coverplate.
- G. Wall mounted passive room occupancy sensor with off-auto switch, capable of controlling fluorescent electronic ballast or incandescent loads, white, 1200 watts at 277v and 600 watts at 120v. Leviton #6775-w or equal by Watt Stopper or Lightolier.
- H. Matching white thermoplastic coverplates shall be provided for all wiring devices located in office areas. Wiring devices shall be ganged with a common coverplate, whenever possible.
- I. Stainless Steel coverplates shall be provided for all wiring devices located in Lab and General Use areas. Wiring devices shall be ganged with a common coverplate, whenever possible.
- J. Die-cast zinc weather-resistant covers shall be provided for all wiring devices located in Wet areas. Wiring devices shall be ganged with a common coverplate, whenever possible.
- K. Poke-thru floor outlets shall be UL-listed for use in the floor slab where they are used and shall have the devices or features noted or scheduled on the drawings. Poke-thru floor outlets shall be as manufactured by Square D, Raceway Components, Inc., Hubbell or Nelson Electric.
- L. Flush floor outlet boxes shall be furnished complete with all required trim and accessories. Cast iron floor boxes shall be used in concrete slabs with a vapor barrier and galvanized steel floor boxes shall be used in all other concrete slabs.

12. ELECTRICAL EQUIPMENT

- A. All electrical equipment used on the project shall, to the maximum extent possible, be the product of a single manufacturer. All new electrical equipment shall be fully compatible with existing equipment. Where new components are added to existing electrical equipment, they shall be manufactured by the existing equipment manufacturer. All outdoor panels shall be nema 3-R.
- B. Safety switches shall be heavy duty type, fuse or nonfused, as noted, and with a solid neutral bus where a neutral is present. Switches shall have a NEMA 1 enclosure for indoor use and a NEMA 3R enclosure for outdoor use.
- C. Fuses up to 600 amperes shall be Bussmann "Low Peak", Class RK1 current limiting fuses, LPS-R (600 volt) or LPN-R (250 volt). Fuses 601 amperes and larger shall be Bussmann KRPC type current limiting fuses.
- D. Each piece of electrical equipment shall have a screw secured, engraved plastic nameplate. Nameplates shall indicate equipment type, designation, voltage and equipment served, as applicable. Typed panel schedules indicating circuit numbers, loads served and connected loads for all circuits shall be installed behind a lexan cover inside each new and existing panelboard which serves the lease space.

13. VOICE AND DATA OUTLETS

- A. Individual voice and data outlets shall consist of a drywall mounting ring with a grommet in the wall top plate and a pull string up to an accessible ceiling space. Where voice and data outlets are located in areas with inaccessible ceiling spaces and elsewhere where noted on the drawings, voice and data outlets shall consist of a wall outlet box with a 3/4", minimum, conduit with pullstring to an accessible ceiling space or a voice or data terminal board as noted on the drawings.
- B. Voice and data cable shall be furnished, installed and terminated by the tenant.

14. MISCELLANEOUS

- A. Electrical connections to tenant and contractor-furnished equipment shall be the responsibility of this contractor, unless noted otherwise. This contractor shall verify the rough-in requirements for equipment as furnished and shall provide rough-in and final connections as required.
- B. Miscellaneous electrical controls and equipment shall be furnished and installed as noted on the drawings. This contractor shall be responsible for furnishing all miscellaneous control power connections to equipment furnished by this contractor or the tenant, general contractor or other contractors.
- C. HVAC temperature controls, control devices and control wiring shall be furnished and installed by the mechanical contractor. This contractor shall be responsible for furnishing 120 volt power connections to the HVAC temperature controls as shown on the drawings and as required.
- D. Furnish and install security systems provisions, where shown on the drawings. Prior to installation, coordinate the exact rough-in requirements with the selected security vendor.
- E. Provide all material and equipment to make the final connections to all equipment, appliances and furniture including any flexible conduit for furniture connections not furnished with furniture.

- F. Furnish access doors to the general contractor, for installation by the appropriate trades, in locations where access is required to electrical equipment which would otherwise be inaccessible. Care should be taken in locating electrical equipment to minimize the number of access doors required. Final locations of access doors in finished areas shall be approved by the architect. Access doors shall be as specified by the architect. Where no architectural access door specification exists, then access doors shall be as follows:

Drywall partitions _____	Inryco/Milcon Style DW
Drywall ceilings _____	Inryco/Milcon Style DW or Style WB-PL as directed by the architect
Plaster walls or ceilings _____	Inryco/Milcon style WB-PL

15. MOUNTING HEIGHTS

- A. Mounting heights for electrical devices shall be as follows, unless noted otherwise on the electrical or architectural drawings or required to match existing installations or handicapped codes:

Wall switches _____	45" above finished floor
Wall receptacles _____	18" above finished floor with long axis vertical. Above counter receptacles 6" above counters without backsplashes or 4" above backsplash for counters with backsplashes, with long axis horizontal
Voice and data outlets _____	18" above finished floor
Wall telephone outlets _____	45" above finished floor
Panelboards _____	72" above finished floor to top of panel
Fire alarm pull stations _____	45" above finished floor
Fire alarm wall signals _____	80" above finished floor or 6" below finished ceiling, whichever is lower.

END OF SPECIFICATIONS